

# VITO ERSO

MCA

furniture

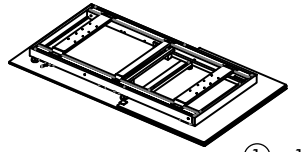

① × 1

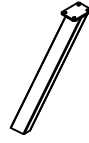

② × 2

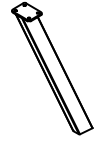

③ × 2



M8 × 20mm  
④ × 16



φ17\*φ8\*2.0  
⑤ × 16



5#  
⑥ × 1

1

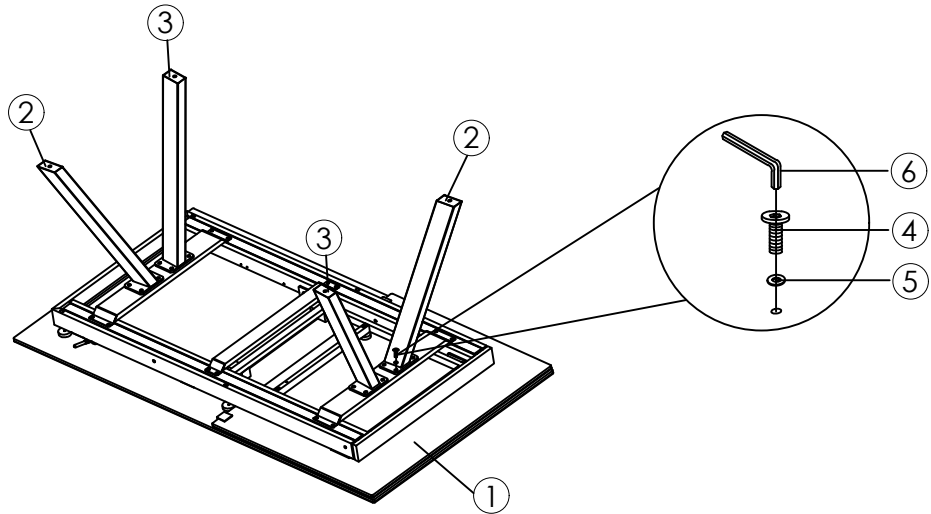

2

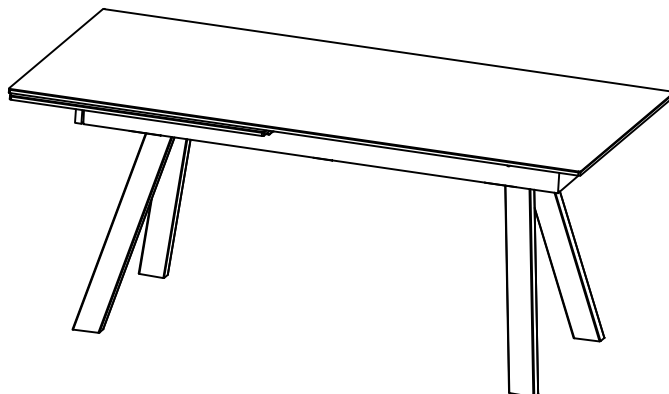

3

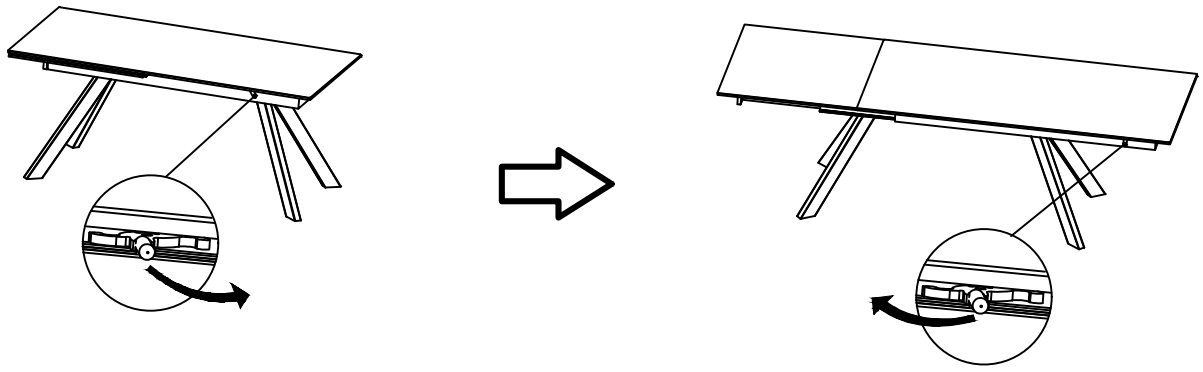

4

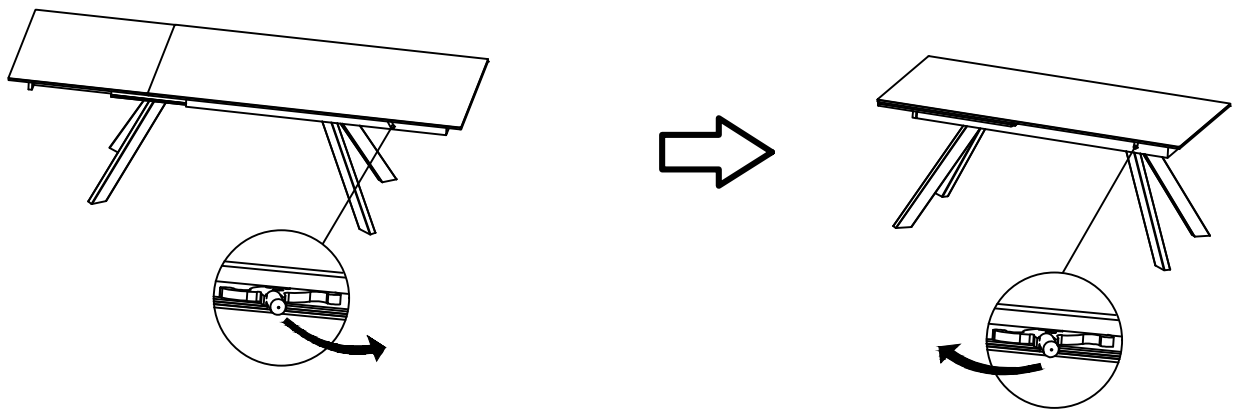

5

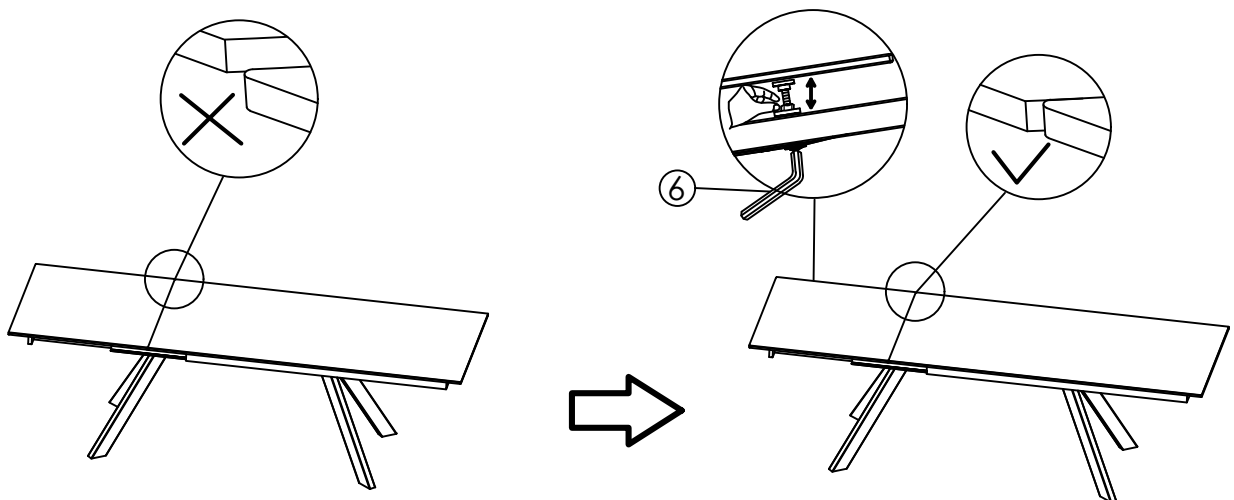

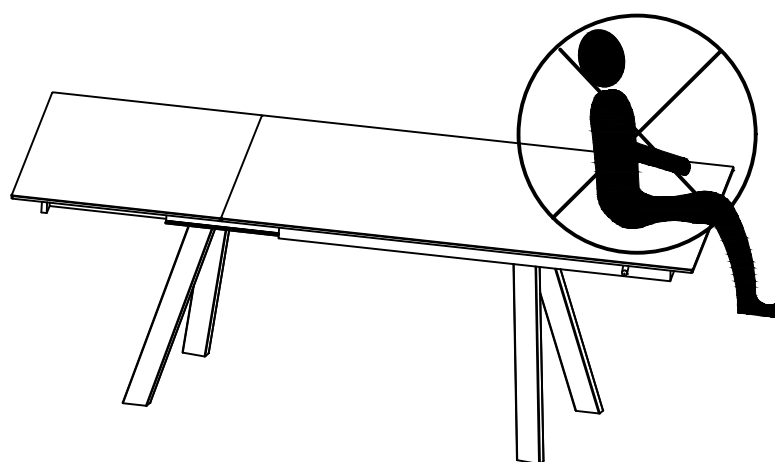
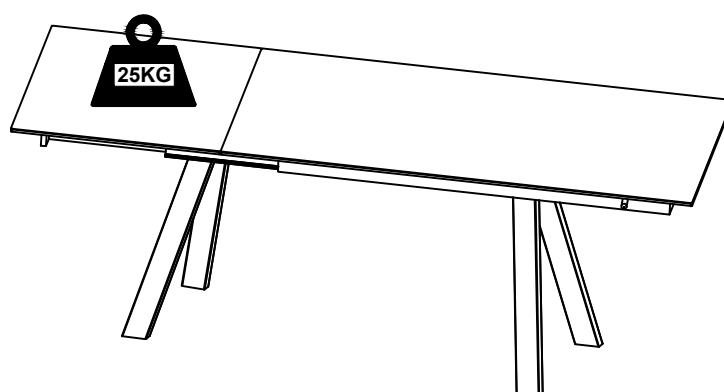
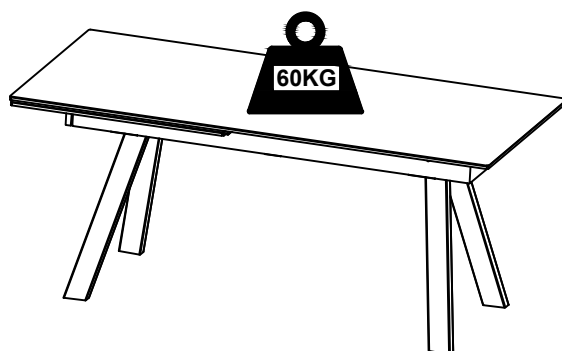

# MCA

furniture

D	<p>Transporthinweis: Den Tisch bitte nicht im ausgezogenen Zustand anheben, da sonst die Seilzüge reißen könnten.</p>	DA	<p>Transporthenvisning: Bordet må ikke løftes i udtrukket tilstand, da trækwirene derved kan springe!</p>
EN	<p>Transport instruction: Please do not lift the table when extended as this may cause the cables to break!</p>	ES	<p>Advertencia para el transporte: ¡No levante la mesa mientras esté desplegada, ya que los cables de tensado podrían partirse!</p>
FR	<p>Consigne de transport : Ne pas soulever la table une fois rallongée car les câbles de traction pourraient se rompre.</p>	HR	<p>Napomenazatransport: Stol ne podižite u izvučenom stanju jer bi se mogla otkinuti užad!</p>
NL	<p>Transportinstructie: Gelieve de tafel niet in uitgetrokken toestand op te tillen; zo niet kunnen de kabelopen scheuren!</p>	PL	<p>Wskazówka dotycząca transportu: Nie należy podnosić stołu w postaci rozłożonej, ponieważ cięgną mogą zostać zerwane!</p>
SK	<p>Pokyn pre prepravu: Nenadvihujte stôl vo vytiahnutom stave, pretože inak by sa mohli roztrhnúť lankové tiahla!</p>	SL	<p>Napotek za transport: Mize ne dvigujete, če je iztegnjena, ker bi se žice lahko pretrgale!</p>
SV	<p>Transportinformation: Lyft inte bordet i utdraget tillstånd då annars linaljan kan gå sönder!</p>	IT	<p>Istruzioni di trasporto: Non sollevare il tavolo allungato per evitare di rompere le allunghe.</p>