

Ⓛ Aufbauanleitung

Ⓛ Notice de montage

Ⓛ Handleiding voor de montage

Ⓛ Montážní návod

Ⓛ Szerelési útmutató

Ⓛ Montaj talimatları

Ⓛ Assembly instruction

Ⓛ Istruzioni di montaggio

Ⓛ Instrukcja montażu

Ⓛ Navod na montaž

Ⓛ Instrucțiuni de montaj

Ⓛ Инструкция по монтажу

# 36-1010-32-000

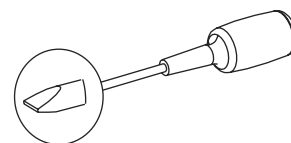
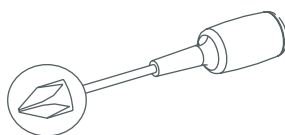
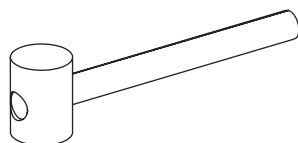
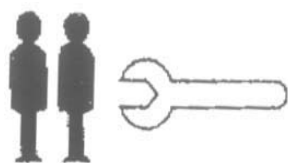
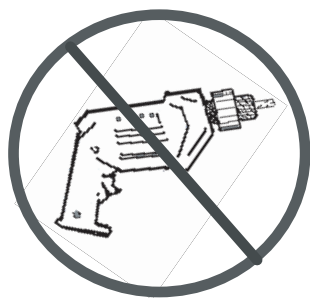
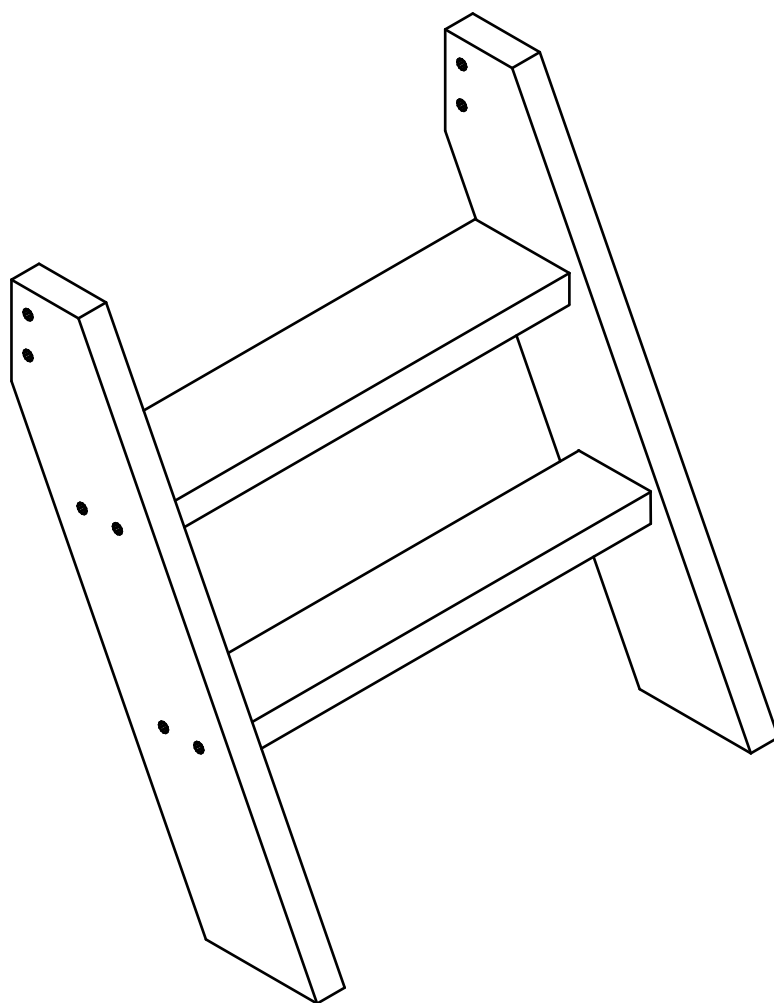

0  
10  
20  
30  
40  
50  
60  
70  
80  
90  
100  
110  
120  
130  
140  
150  
160  
170  
180

Service  
Serwis

Dienstverlening  
Servis

Dienst kaart  
Сервисная служба

Name • Naam • Naam • Isim • Название

Nr. • No. • Номер

Typ • Type • Тип • Тип

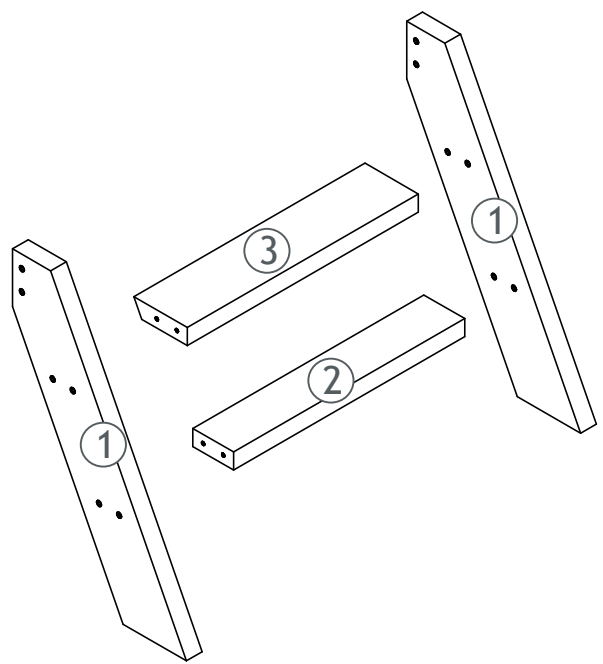
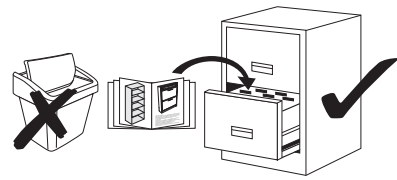
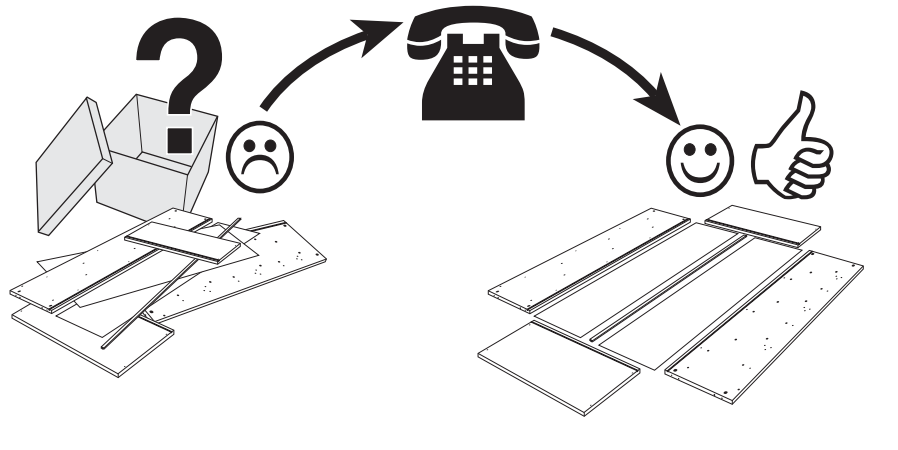

①	198100-32	x2
②	198101-32	x1
③	198102-32	x1

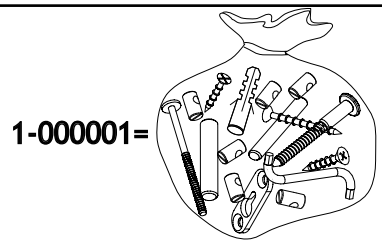
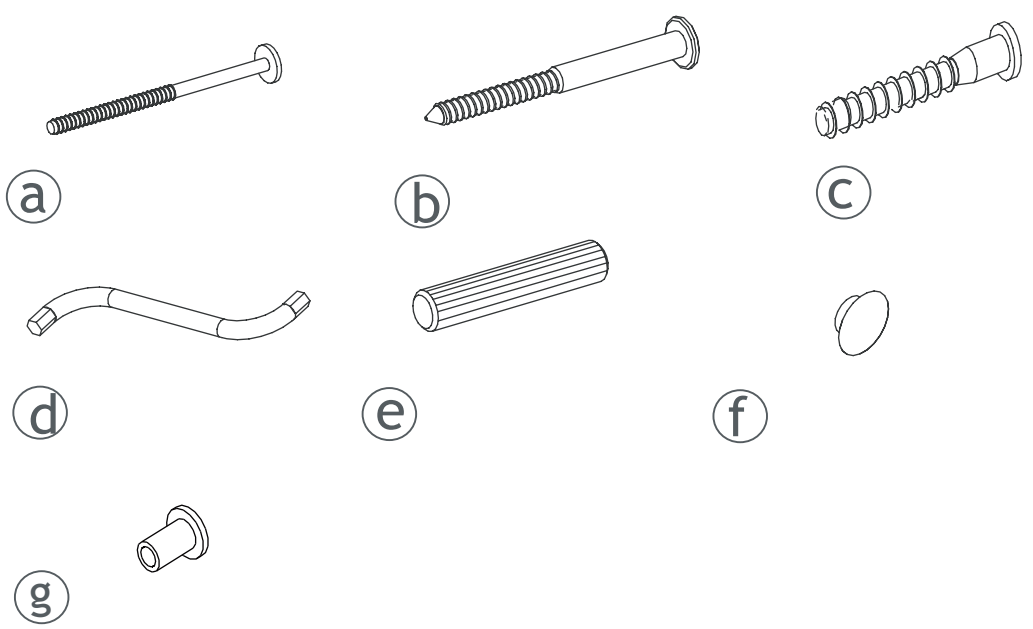
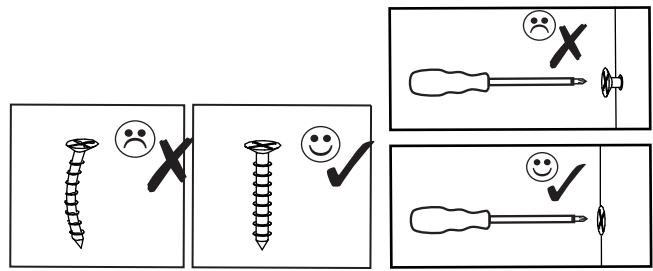

		mm	
a	1-000200-07	M6x70	x1
b	1-000098-07	6,3x90	x1
c	1-000099-07	7x50	x8
d	1-000015-07	Z4	x1
e	1-000109-00	8x30	x2
f	1-000014-57	6x8	x2
g	1-000012-07	8x15	x1

# 1.

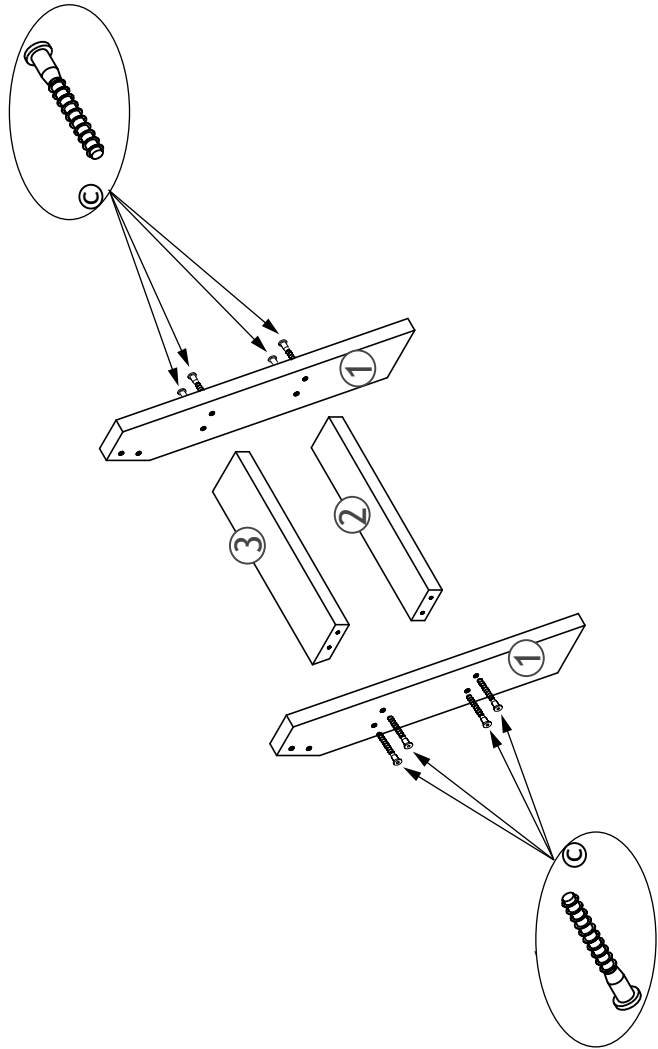

- ① Empfohlene Matratzengröße 90mm!
- Ⓔ E:aisseur de matelas recommandée : 90mm!
- Ⓔ Aanbevolen matras dikte is 90 mm
- Ⓔ Doporučená tloušťka matrace je 90 mm!
- Ⓔ Az ajánlott matracméret 90 mm!
- Ⓔ Önerilen yatak şilte kalınlığı 90 mm'dir!
- Ⓔ Recommended mattress thickness 90mm!
- Ⓔ Spessore consigliato del materasso 90mm!
- Ⓔ Zalecana grubość materacu 90 mm!
- Ⓔ Odporúčaná hrúbka matrace 90 mm!
- Ⓔ Grosimea recomandată a saltelei este de 90mm!
- Ⓔ Рекомендуемая высота матраса - 90мм

# 2.

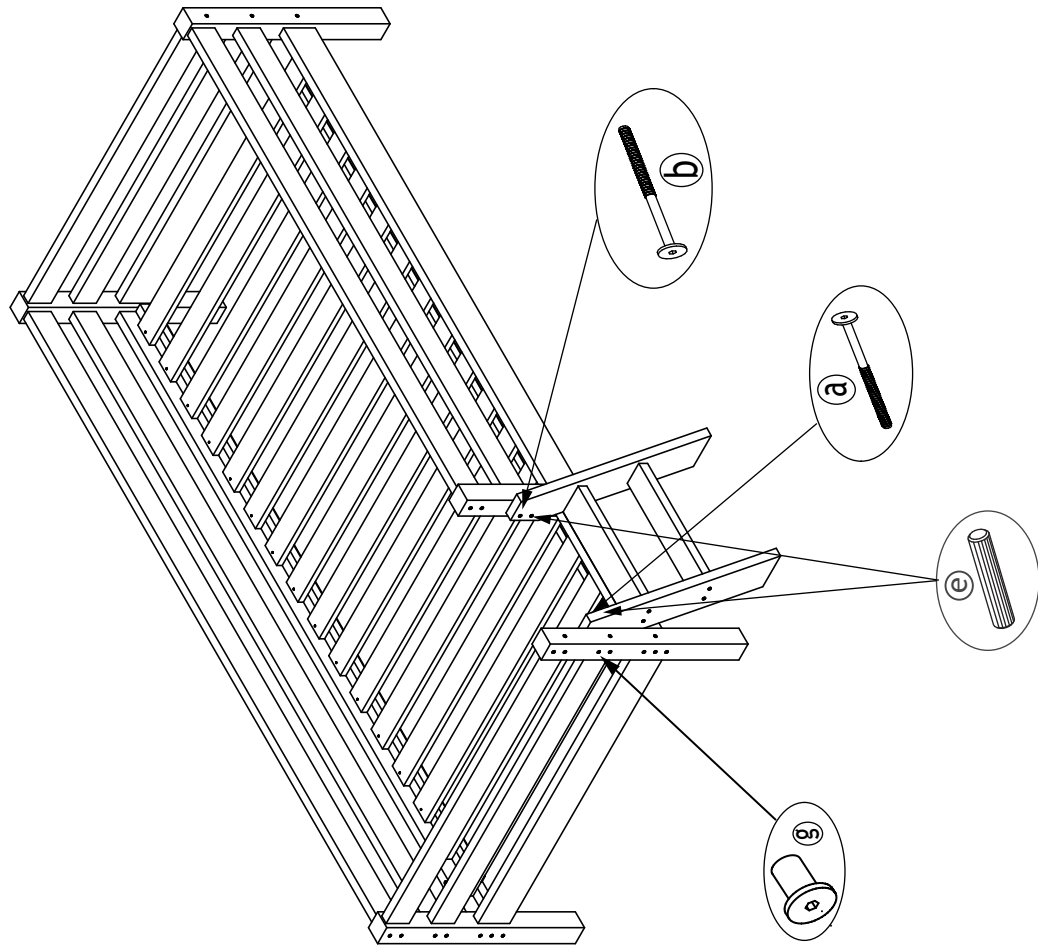

Close free holes with caps  
 Luk alle huller med propper  
 Schliessen Sie die offenen Löcher mit den Deckkappen  
 Fermez les trous découverts avec les chapes

