

REPC-Nr.:

Service • Assistenza • Dienstverlening • Serwis
Servis • Szerviz • Сервисная служба

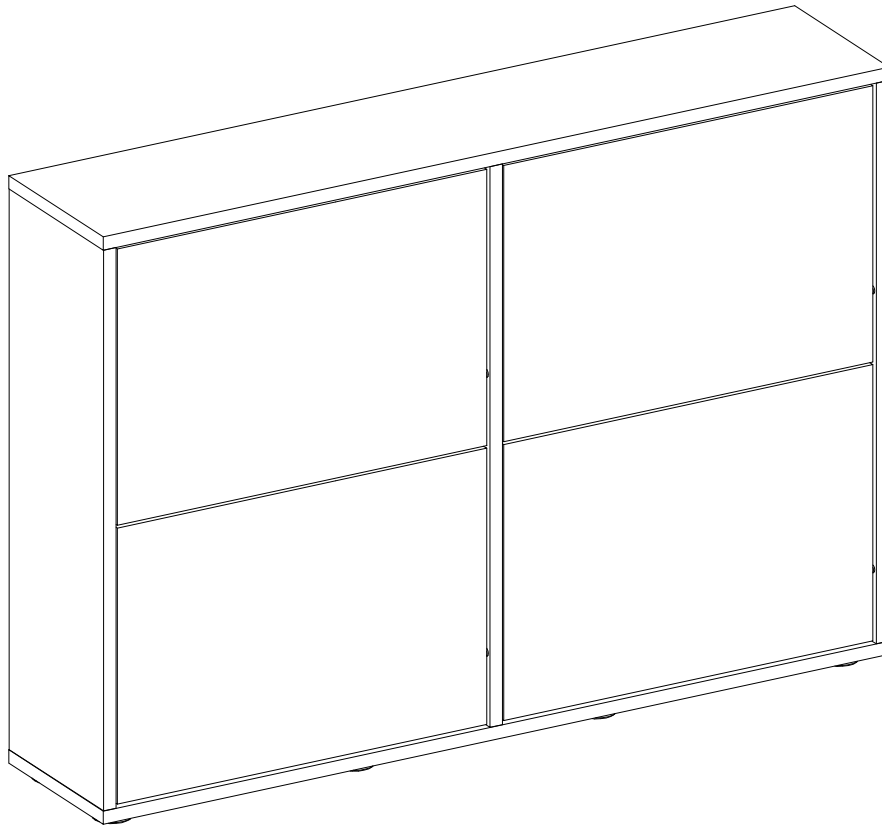

Artikel.-Nr.:

0920-SKI_004 oG

Montageanleitung.-Nr.:

MA1-00345

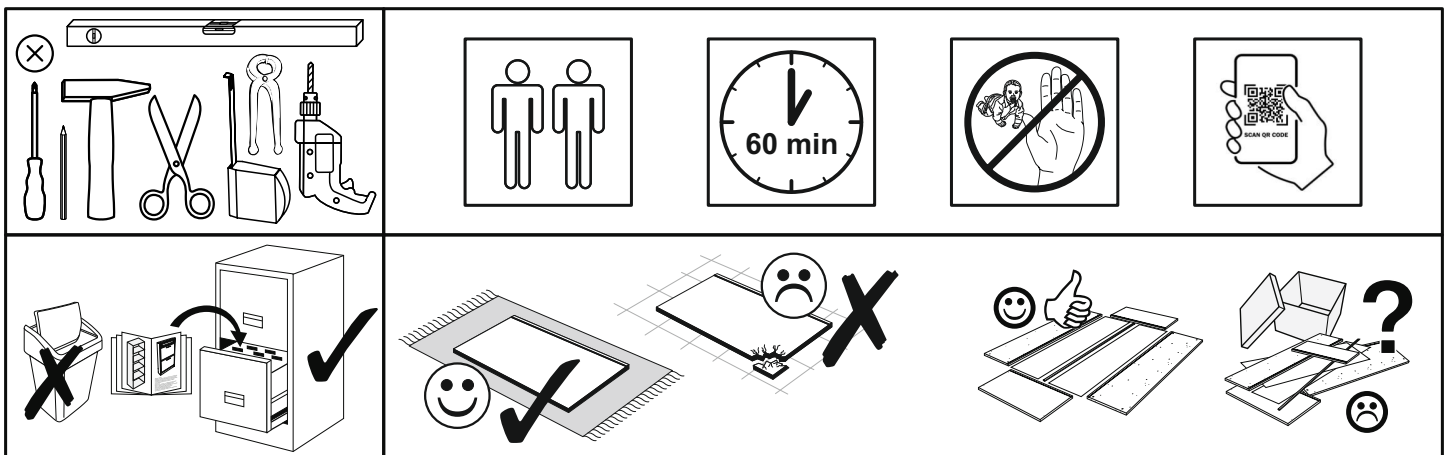

SCAN ME

Das Ersatzteil-Anforderungsformular finden Sie auf
The replacement parts requisition form you find on
<https://www.mausbacher.de/ersatzteile/>

BT1-00468 Colli 1/1

B05-276 1x		B03-81 8x		B03-82 8x	
B05-174 8x		B05-178 8x		B05-121 8x	

BT1-00005 Colli 1/1

B02-173 8x			B01-123 16x		4,0x15
---------------	--	--	----------------	--	--------

BT1-00456 Colli 1/1

B02-10 14x		ø15x12mm	B02-20 14x		B02-103 2x		8x30	
B01-10 6x		6,3x50	B01-200 32x		6,3x13	B01-80 40x		3,5x13
B08-40 3x		5,8x65	B08-70 3x		ø8mm	B08-80 1x		

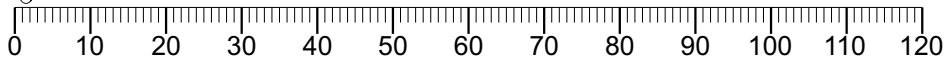
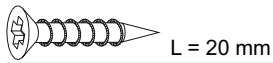

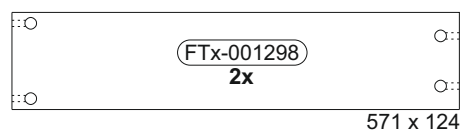
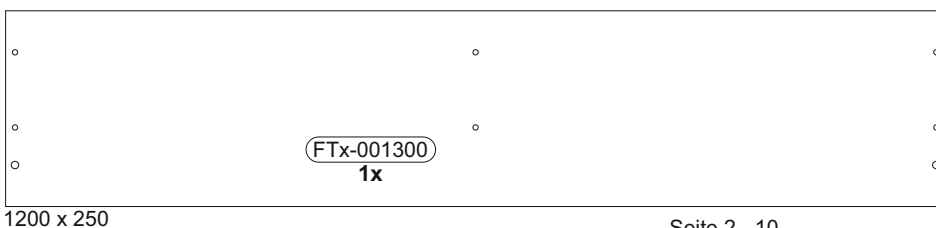
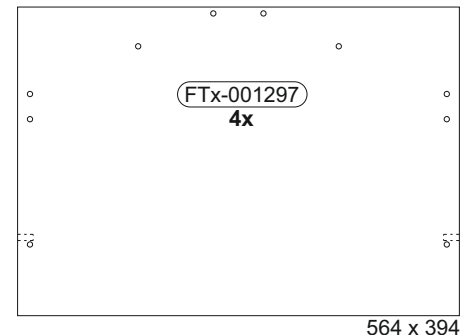
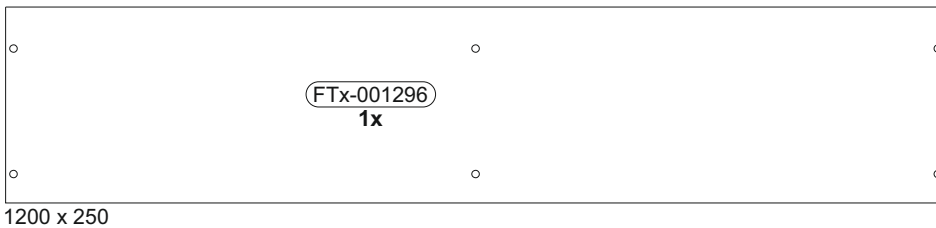
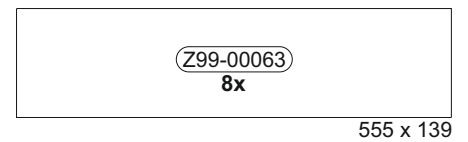
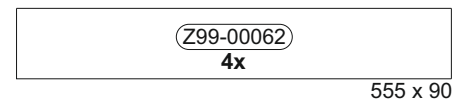
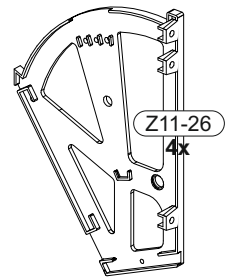
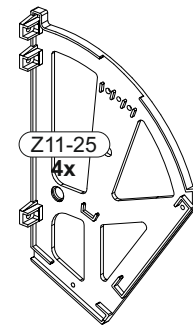
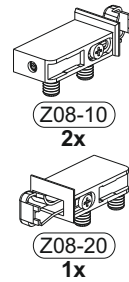
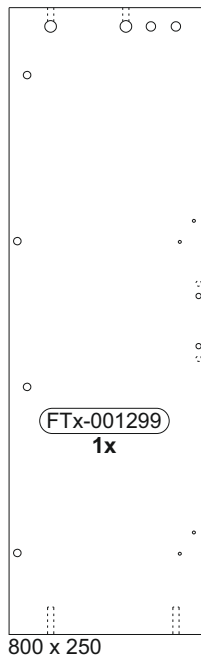
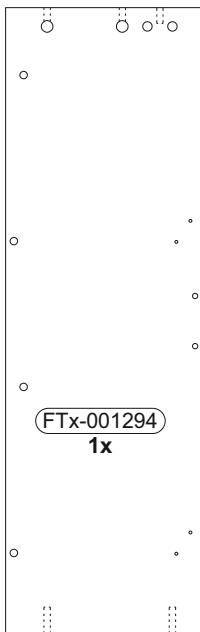

▶ SCAN ME

Colli 1/1

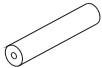

1

	B01-200		B01-80		B05-178	
	24x	6,3x13	24x	3,5x13	8x	

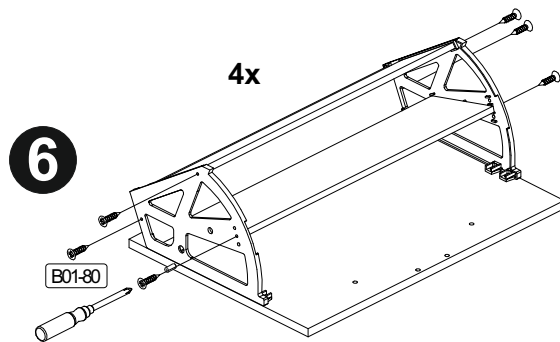
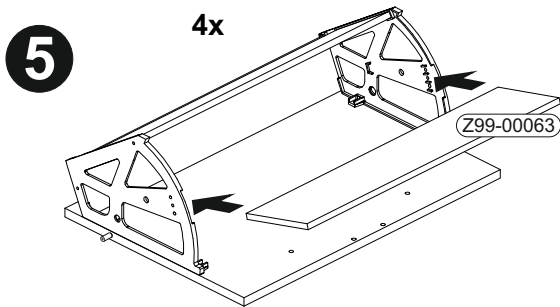
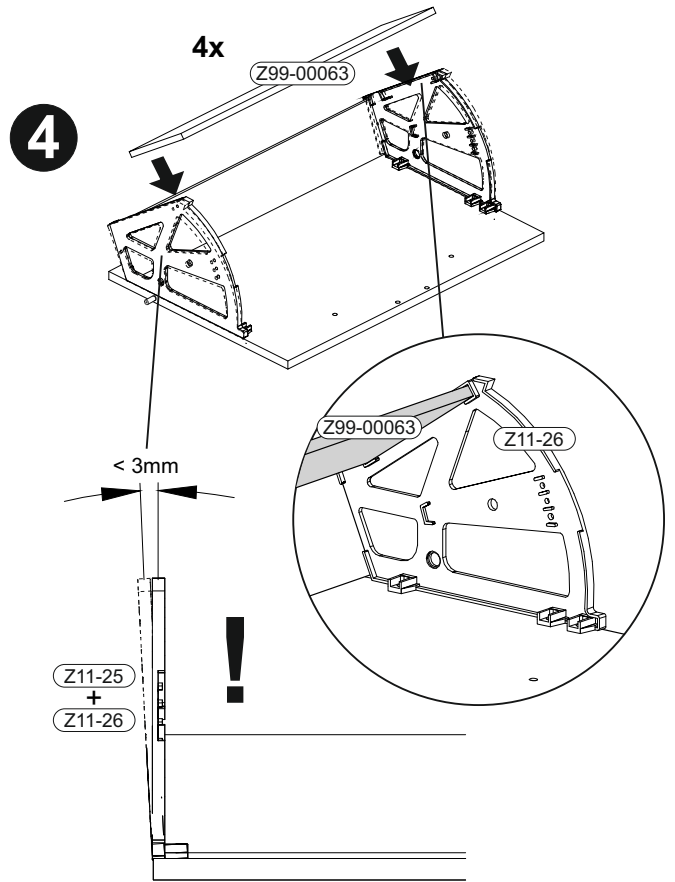
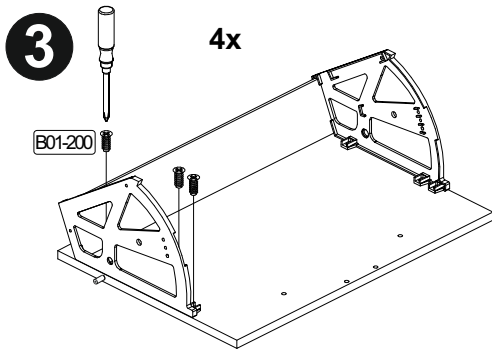
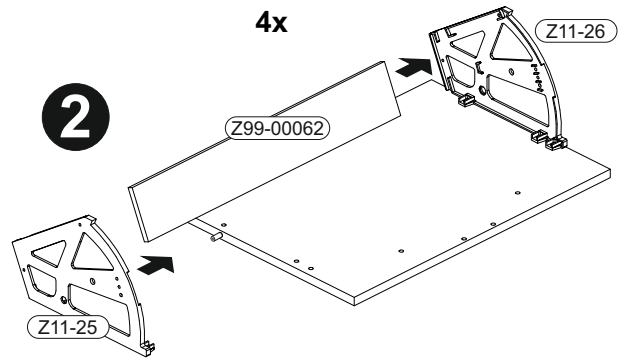
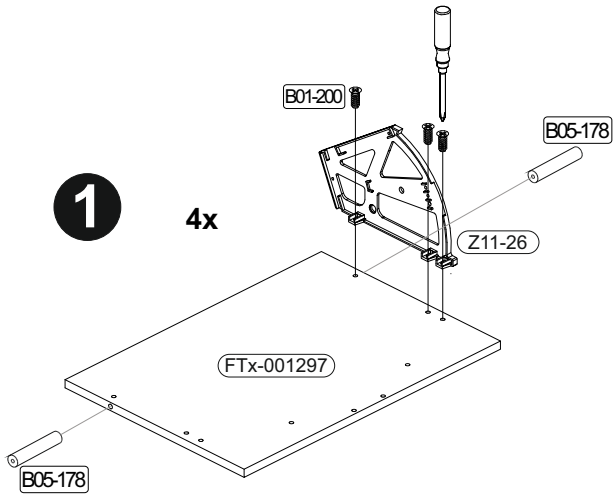

2

	B02-10 4x	 ø15x12mm	B02-20 4x		B02-103 2x	 8x30	B05-121 4x		B01-80 8x	 3,5x13
					B03-81 4x		B03-82 4x		B05-174 4x	

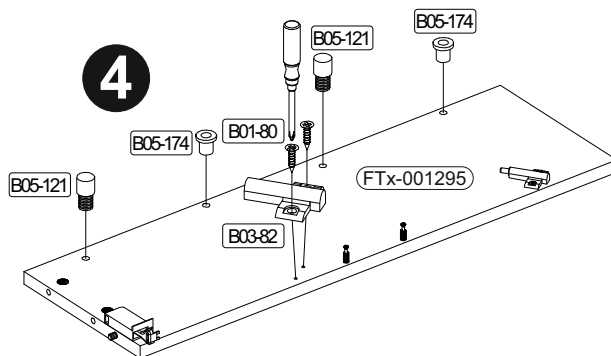
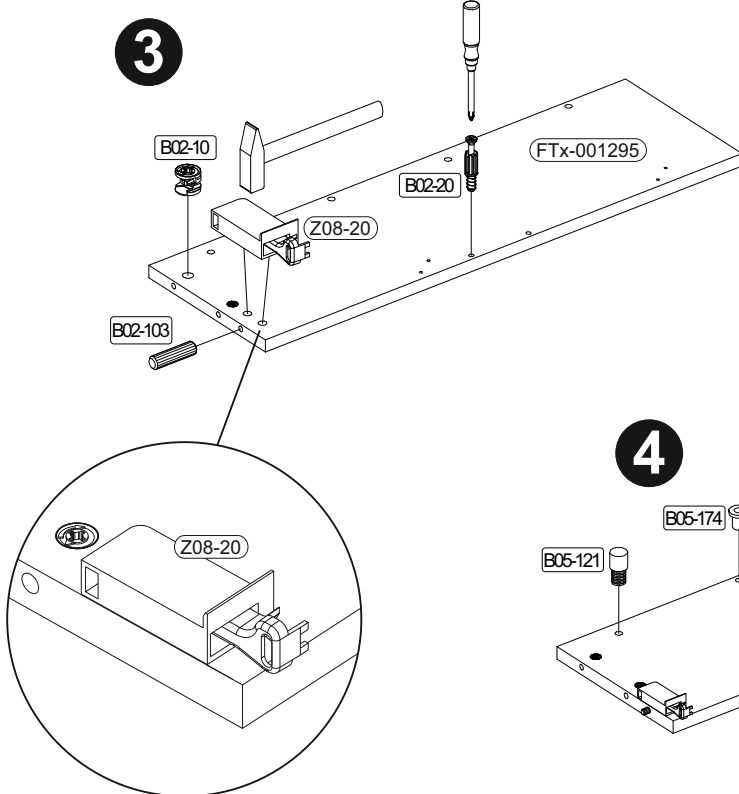
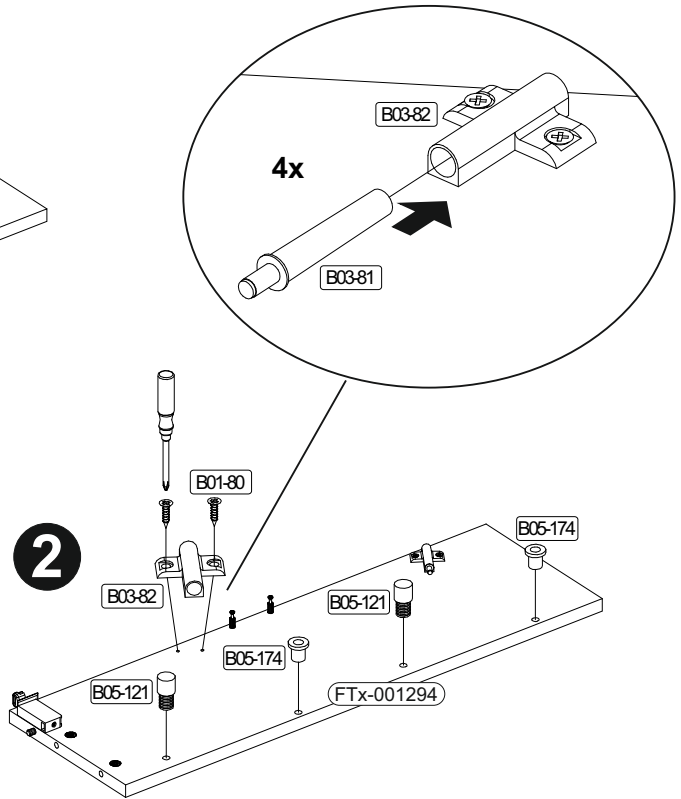
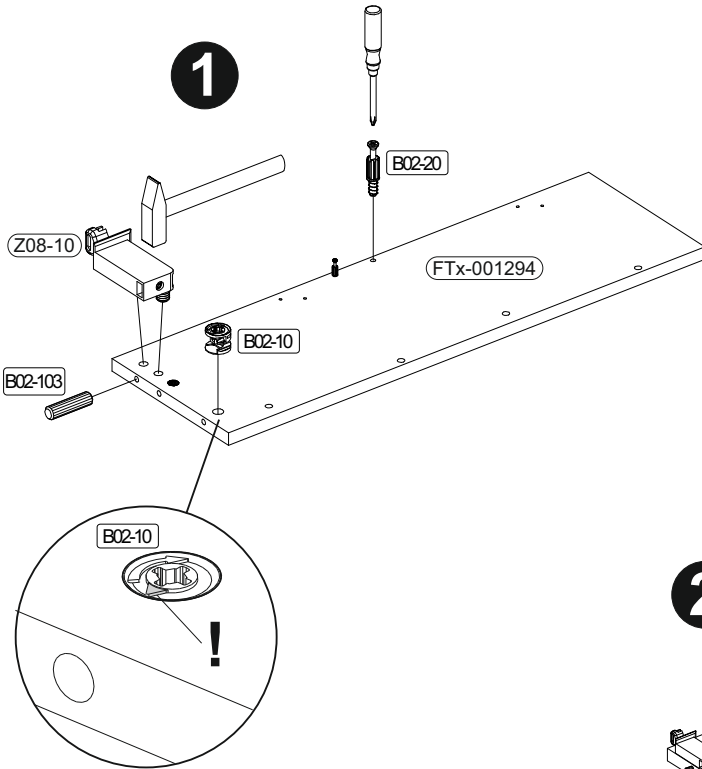

3

	B02-10		B02-20		B01-80		B05-121		B05-174	
	2x	ø15x12mm	4x		8x	3,5x13	4x		4x	
							B03-81		B03-82	
							4x		4x	

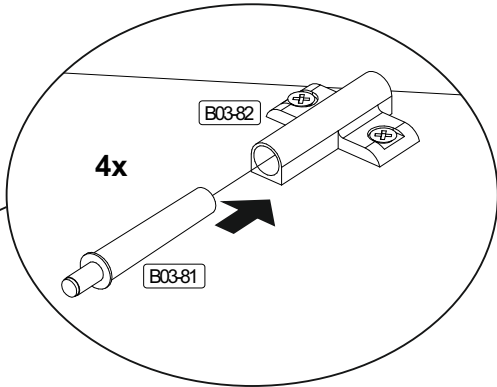
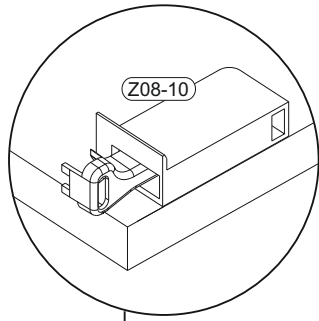

1

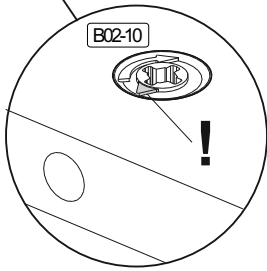
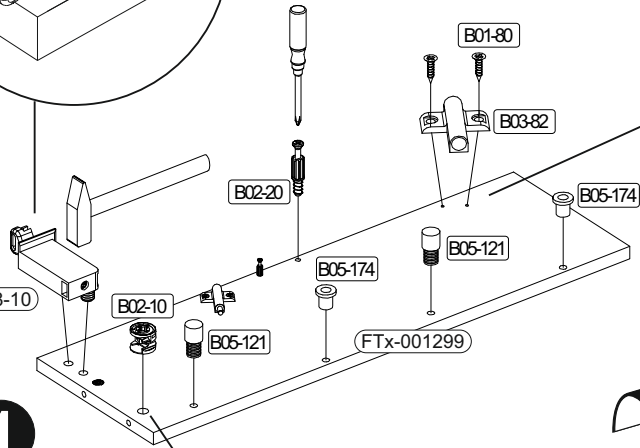

180°

2

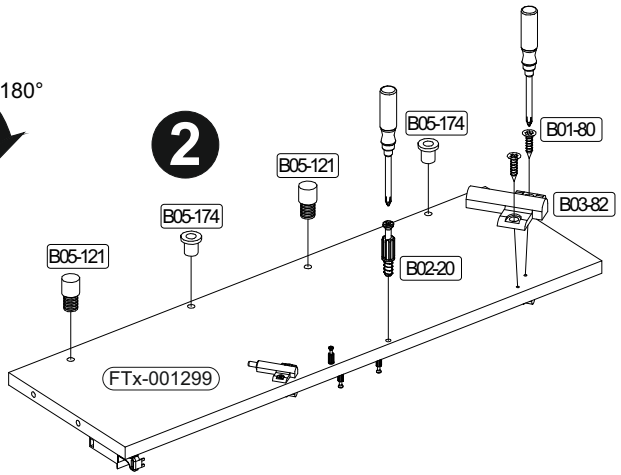

4

	B02-20	
	6x	

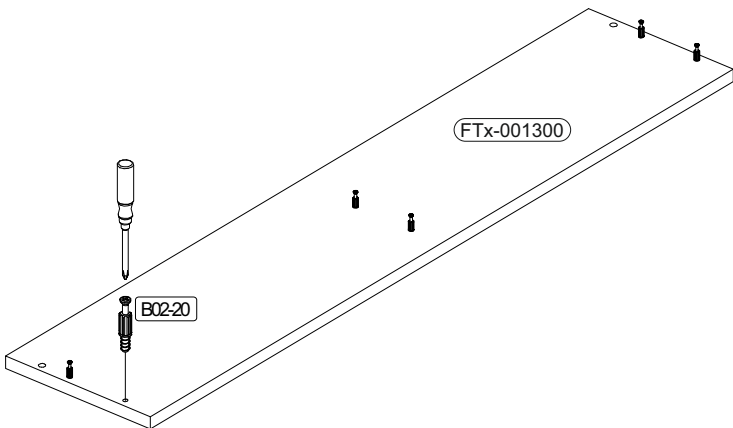

5

	B02-10	
	8x	ø15x12mm

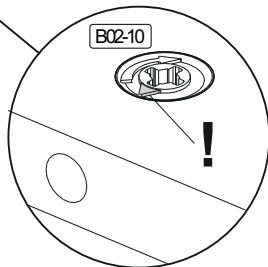
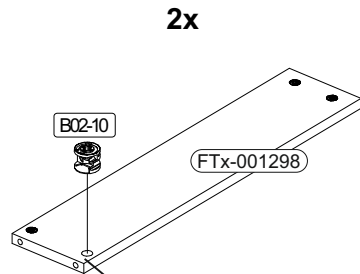

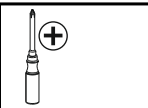
6 

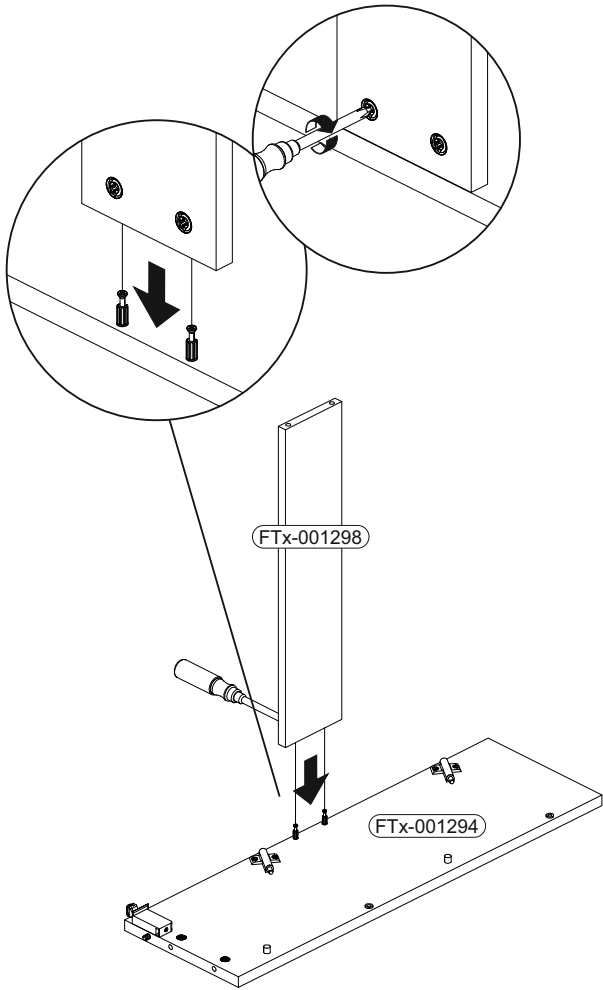

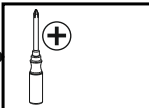
7 

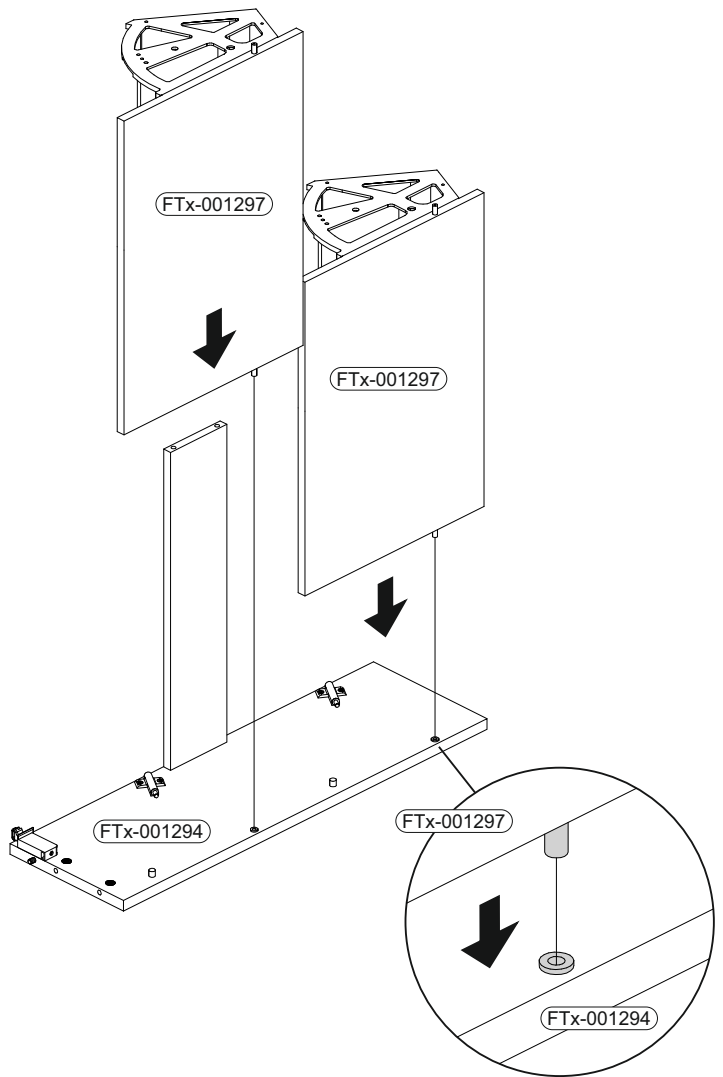

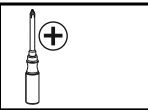
8 

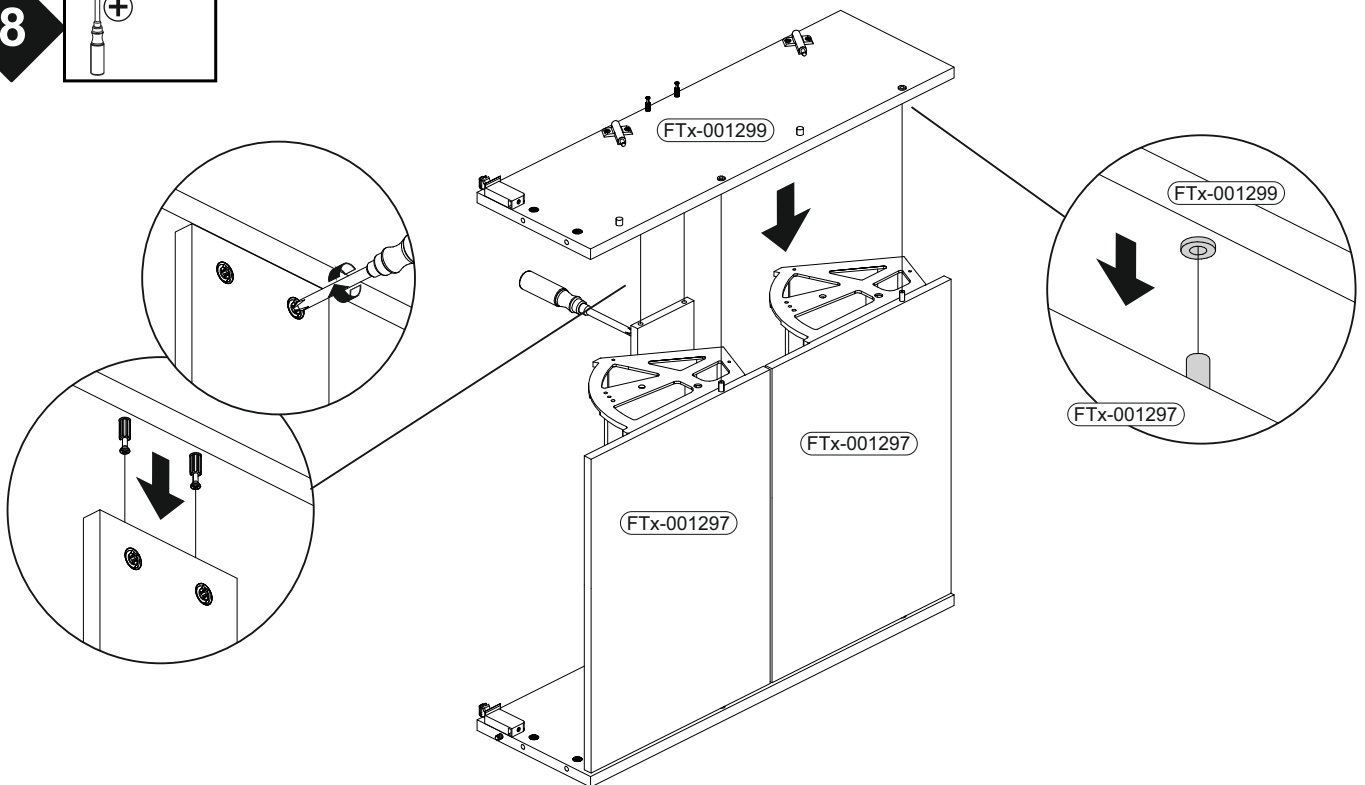

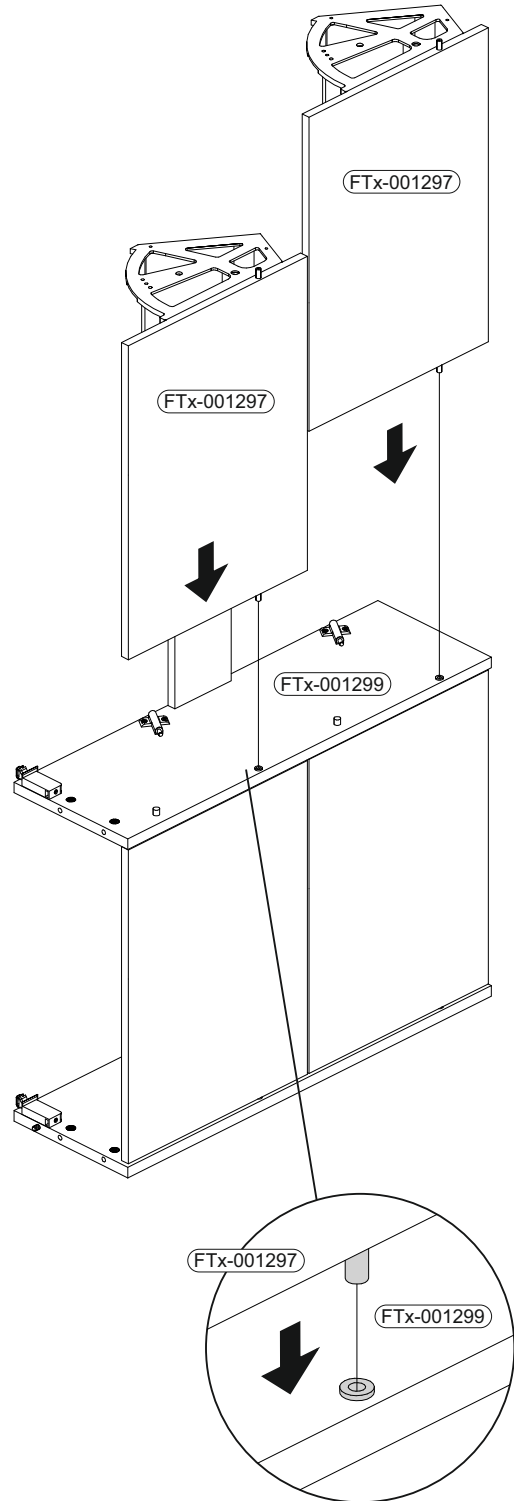
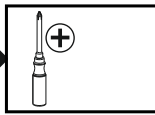
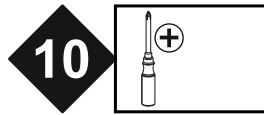
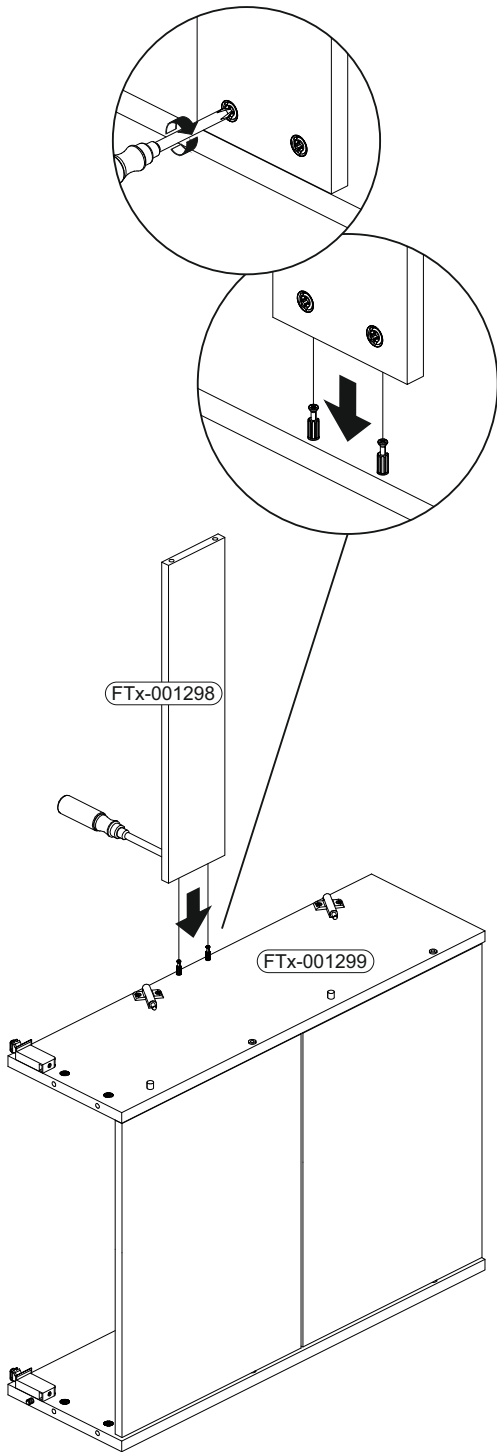
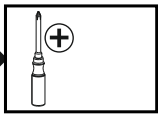
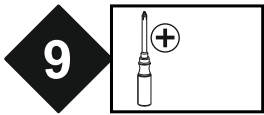



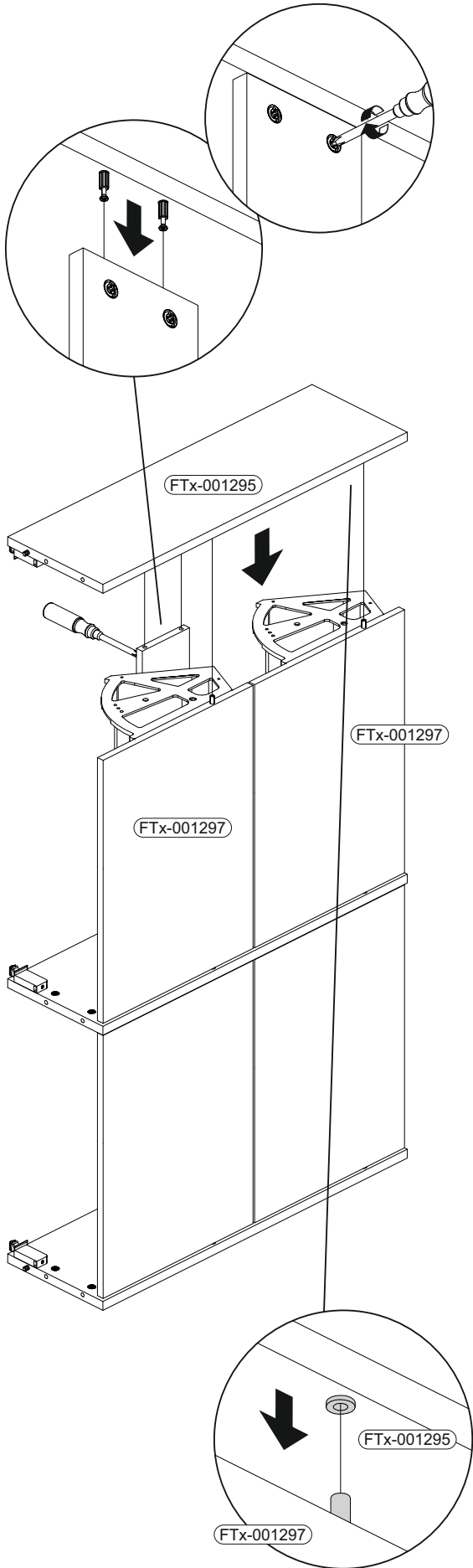
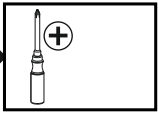

11

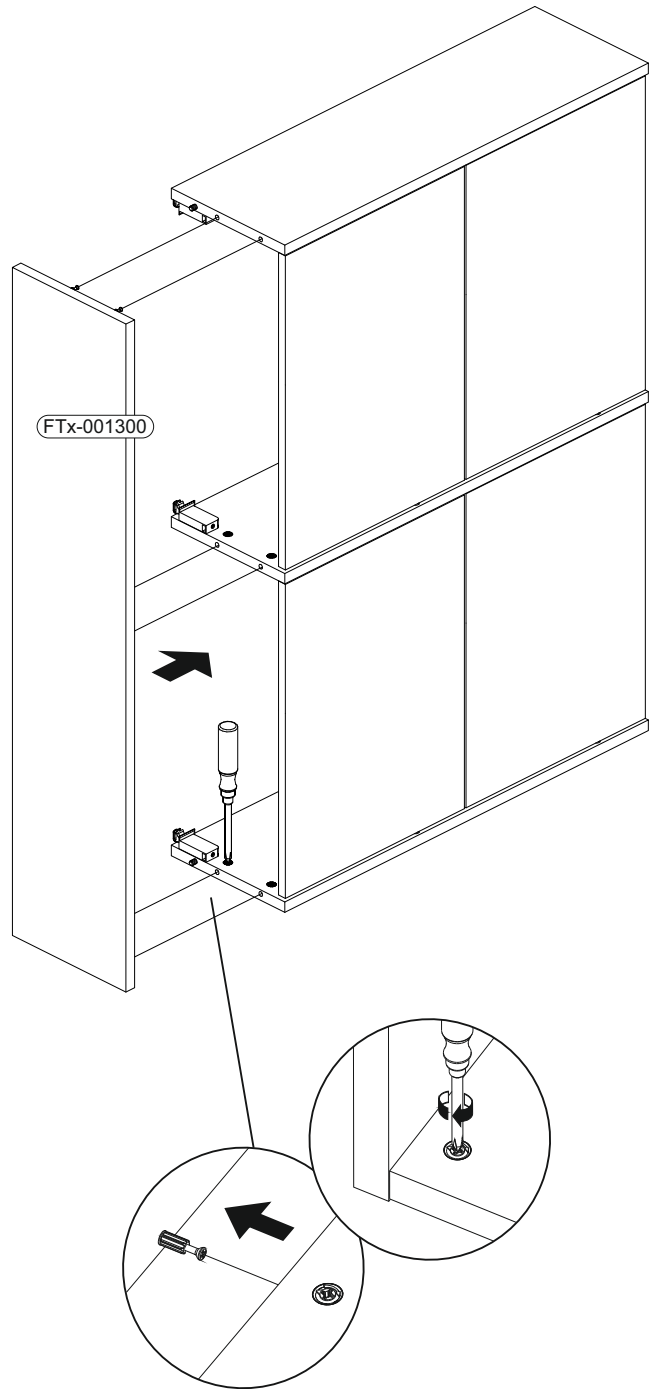
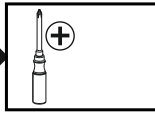

12



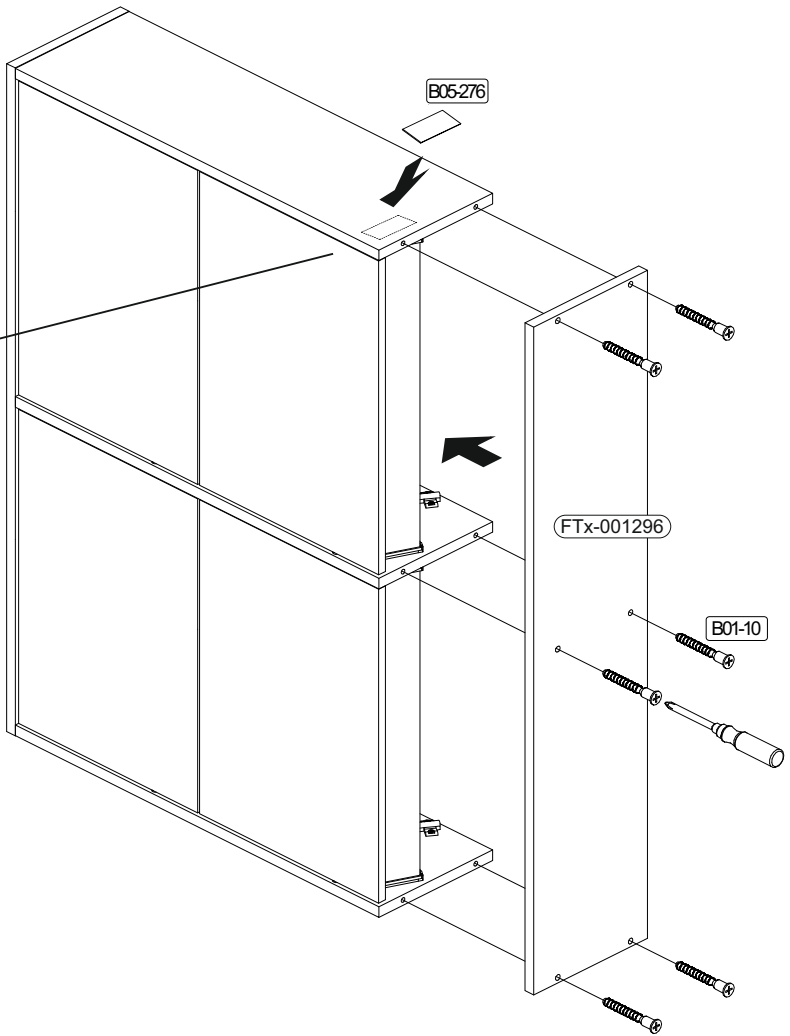

13

	B01-10	 6,3x50
	6x	
B05-276	 Mein Leben. Mein Zuhause.	
1x		

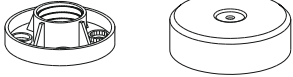

14

	B01-123	 4,0x15
	16x	
B02-173		
8x		

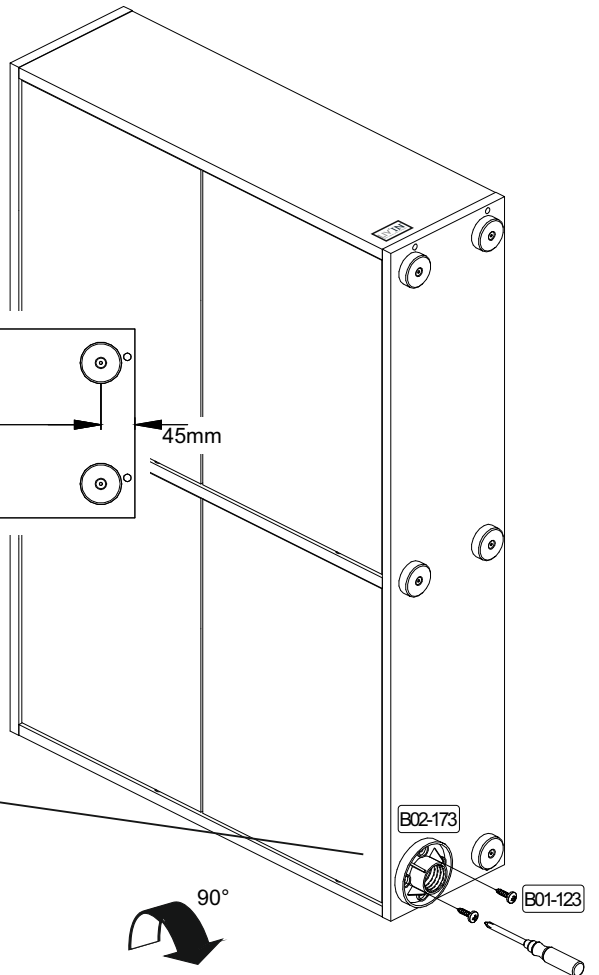
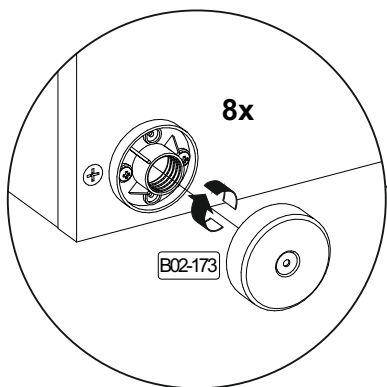
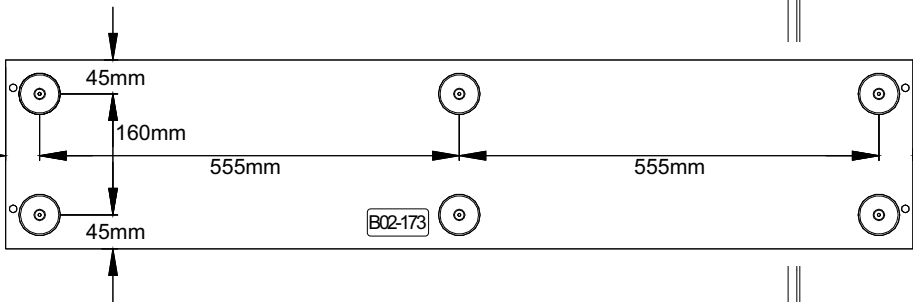

15

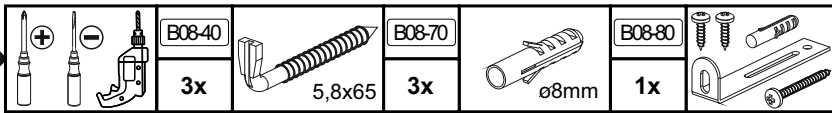

▶ SCAN ME

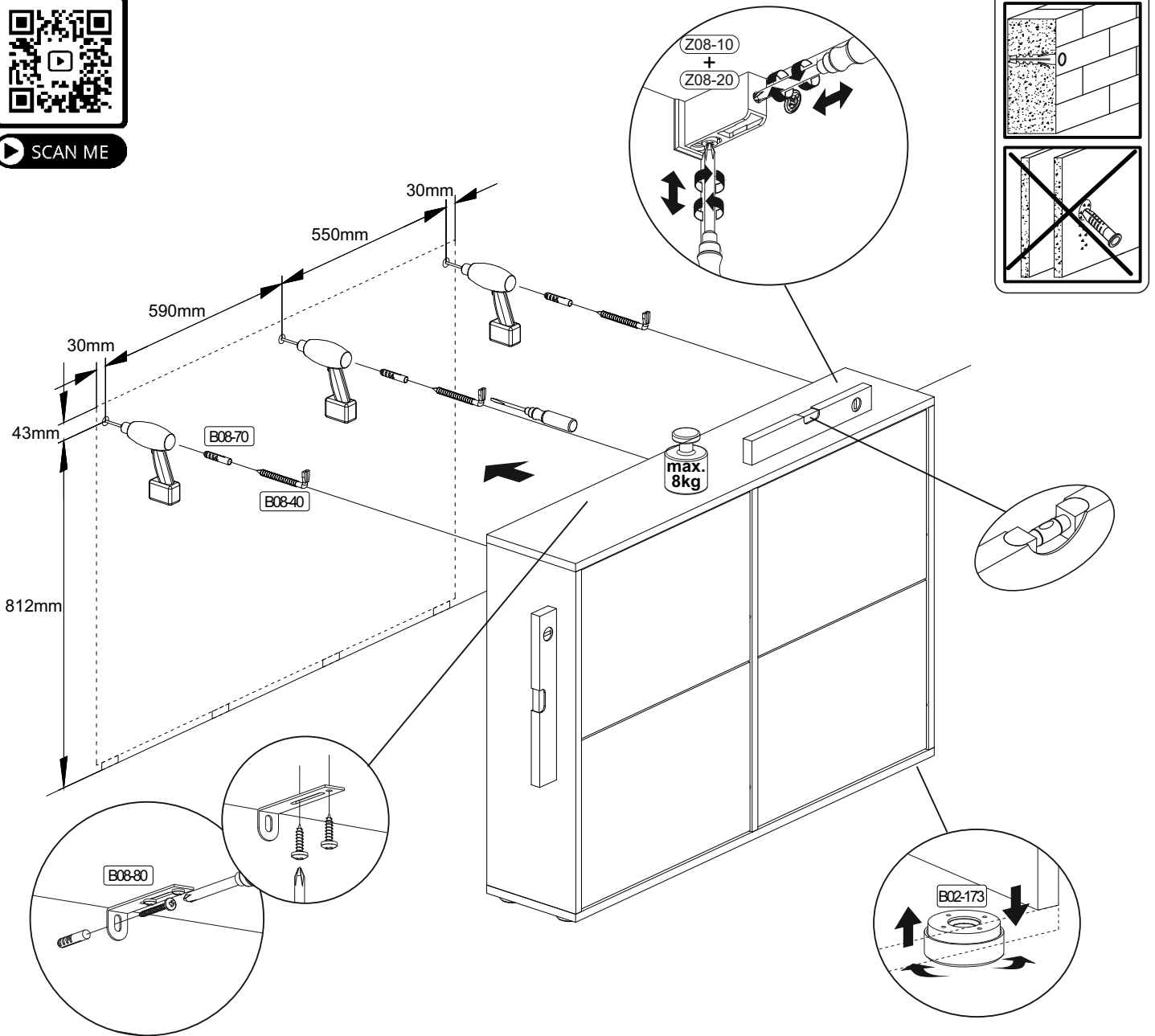

Achtung • Attention • Attenzione • Opgelet • Uwaga • Pozor • Figyelem • Atenție • Dikkat • Внимание	
(D)	Wandbefestigung dient als Kippschutz - unbedingt anbringen! Bei einigen Wandtypen kann ein Spezialdübel erforderlich sein!
(GB)	The wall fastening serves to prevent tipping - be absolutely sure to mount it! For certain wall types, a special wall plug may be necessary!
(FR)	La fixation murale sert de protection contre le basculement – à installer impérativement ! Pour certains types de murs il faut des chevilles spéciales !
(TR)	Duvardaki sabitleme, devrilmeye karşı bir emniyet tedbiridir ve mutlaka monte edilmelidir! Bazı duvar tiplerinde bunun için özel bir dübel gerekli olabilir!
(IT)	Il fissaggio alla parete serve da protezione anti-ribaltamento – attaccarla assolutamente! Per alcune strutture di parete può essere necessario un tassello speciale!
(NL)	Bevestiging aan de muur dient als kantelbescherming – zeker en vast bevestigen! Bij enkele muurtypes is een speciale plug misschien vereist!
(RU)	Обязательно установите крепление на стене во избежание опрокидывания! Для некоторых типов стен может потребоваться специальный дюбель!
(CZ)	Montáž na stěnu slouží jako ochrana proti převrhnutí – bezpodmínečně umístěte! U některých typů stěn může být zapotřebí speciální hmoždinka!
(HU)	A terméket a falhoz kel rögzíteni, különben az felborulhat! Egyes faltípusoknál speciális tiplit kell használni!
(RO)	Sistemul de fixare la perete servește ca protecție la răsturnare - de montat obligatoriu! Pentru unele tipuri de pereți este posibil să fie necesar un diblu special!
(SK)	Upevnenie na stenu slúži ako ochrana proti prevráteniu – bezpodmienečne použite! Pre niektoré druhy stien môže byť potrebná špeciálna hmoždinka!
(PL)	Mocowanie do ściany jest jednocześnie zabezpieczeniem przed przewróceniem – koniecznie zamontować! Do niektórych rodzajów ścian koniecznie zastosować specjalne kołki mocujące.