

Garantiekarte / guarantee card

Modell: CERVO 48648 WE5 #10004 /17

Bitte heben Sie die Garantiekarte und den Kaufbeleg auf!

Reklamationen und Ersatzteilbestellungen können nur unter Vorlage der Garantiekarte bearbeitet werden.

Die Garantiezeit beträgt 6 Monaten mit anschließender gesetzlicher Gewährleistung bis 2 Jahre ab Kaufdatum.

Please keep the guarantee card and the receipt of purchase!
Claims and spare part orders can only be processed with this guarantee card.
Guarantee is valid for 6 months and the warranty 2 years since purchasing date.

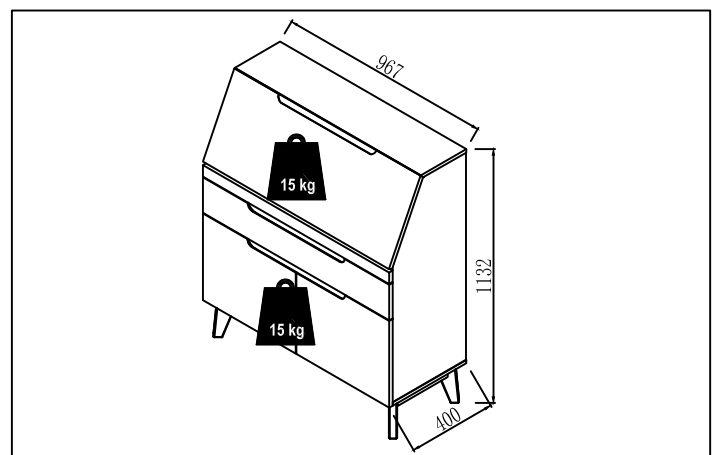
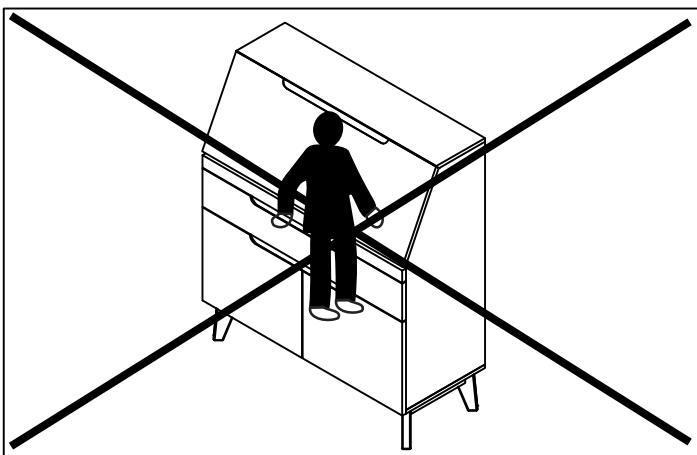
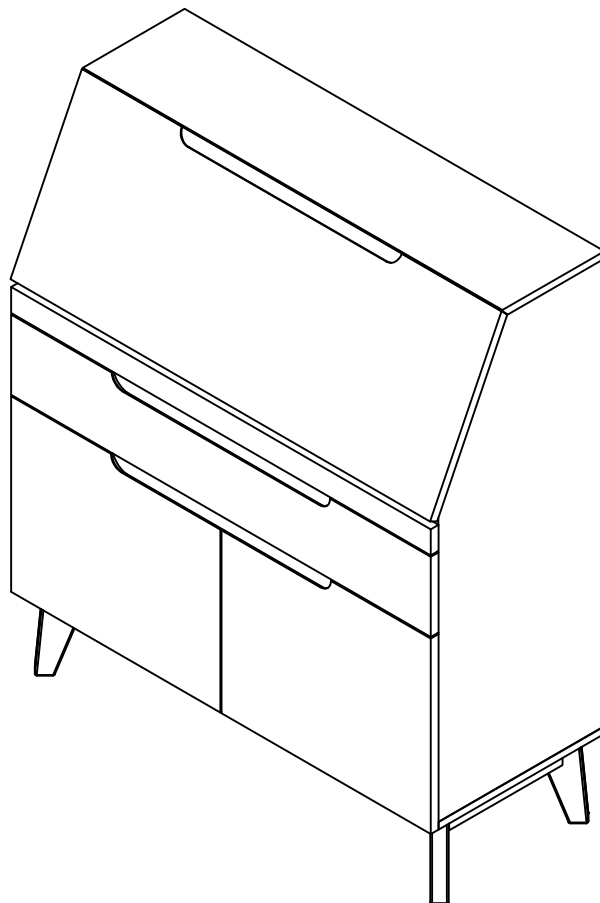

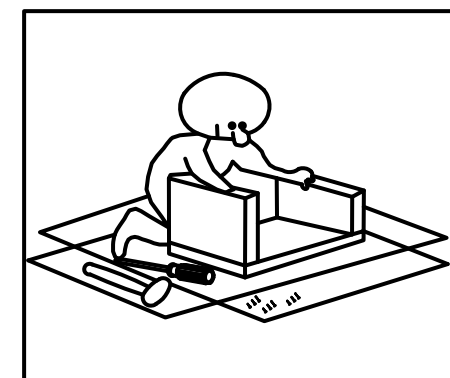
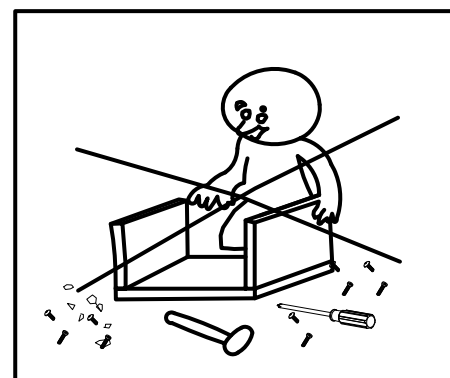
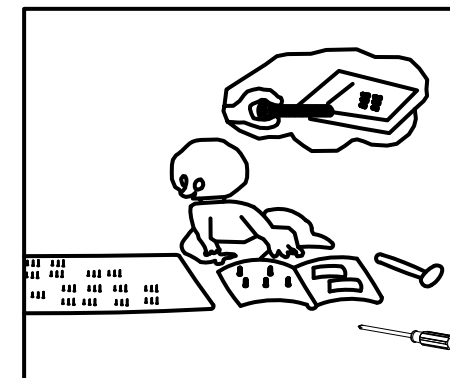
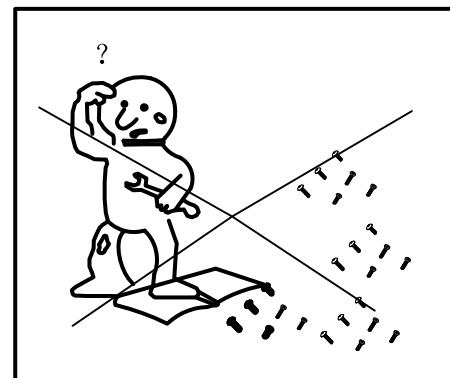
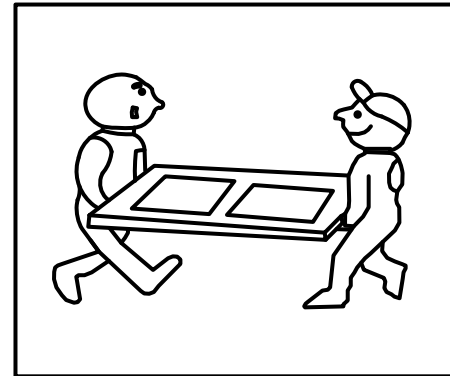
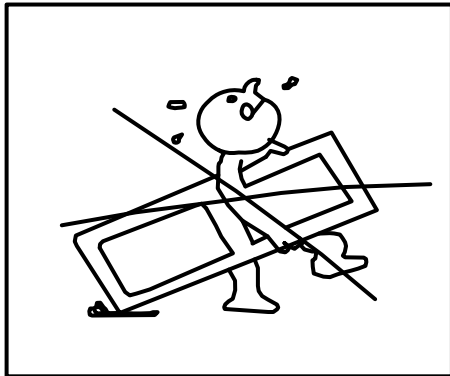
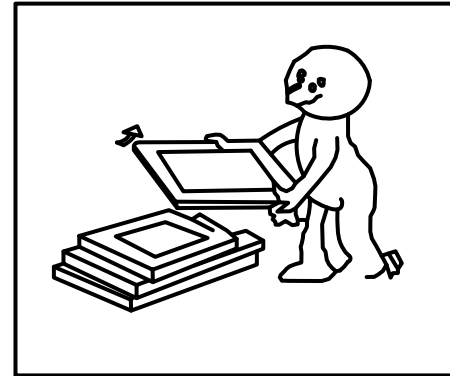
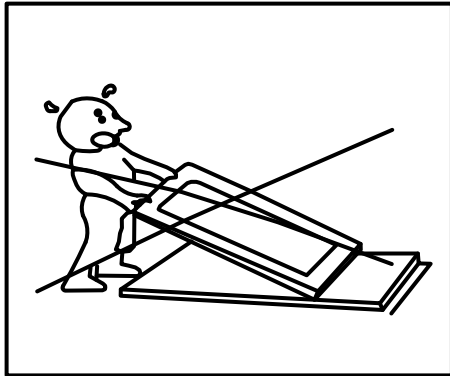
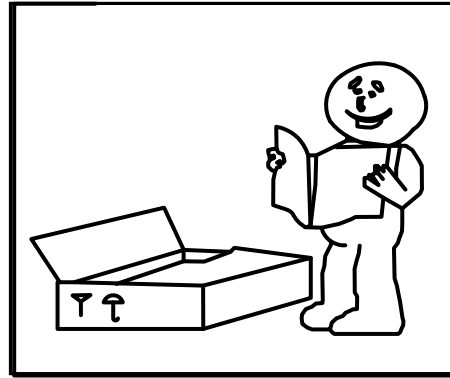
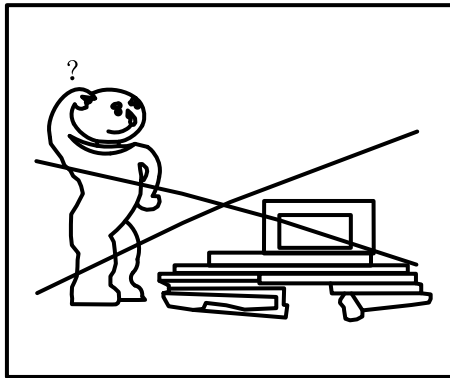



English

Spare parts orders

Should any parts be missing or damaged, please do not forget to indicate the part designation in your order. To ensure quick processing, please send our customer service a copy of the second page on which you mark the part in question with a cross.

Safety instructions

- Packaging material such as plastic bags does not belong in children's hands. Keep the packaging material out of the reach of children.
 - The best way to care for your furniture is to use a soft, lint-free cloth or a leather cloth.
- Wipe the surface with a damp cloth.
- Do not use any microfibre cloths, dirt erasers or aggressive chemical substances.

Deutsch

Ersatzteilbestellung

Sollten Teile fehlen oder beschädigt sein, bitte bei der Bestellung unbedingt die Teilebezeichnung angeben. Für eine schnelle Abwicklung senden Sie bitte eine Kopie der zweiten Seite an unseren Kundendienst, auf der Sie das reklamierte Teil ankreuzen.

Sicherheitshinweise

- Verpackungsmaterial wie z.B. Folienbeutel gehören nicht in Kinderhände. Bewahren Sie das Verpackungsmaterial für Kinder unerreichbar auf.
- Verwenden Sie zur Pflege Ihres Möbels am besten ein weiches, nicht fußelndes Tuch oder ein Ledertuch. Wischen Sie die Oberfläche leicht feucht ab.
- Verwenden Sie keine Microfasertücher, Schmutzradierer und keine scharfen chemischen Substanzen

Svenska

Beställning av reservdelar

Om delar saknas eller är skadade ska alltid beteckningarna av reservdelarna anges vid beställningarna. För att kunna hantera ärendet snabbt, vänligen skicka en kopia av den andra sidan, där

du har kryssat för den reklamerade delen, till vår kundtjänst.

Säkerhetsanvisningar

- Förpackningsmaterial som t.ex. foliepåsar ska hållas bort från barn. Förvara förpackningsmaterialet oåtkomligt för barn.
 - Använd helst en mjuk och luddfri trasa eller en lädertrasa för skötsel av dina möbler.
- Torka av ytan med en lätt fuktig trasa.
- Använd inga mikrofiberdukar, skursvampar eller starka kemiska ämnen.

FRANÇAIS

Commande de pièces de rechange

Si des pièces sont manquantes ou endommagées, veuillez impérativement indiquer la dénomination des pièces lors de la commande. Afin d'assurer un traitement rapide de votre commande, veuillez envoyer une copie de la page 2 à notre service client en cochant la pièce faisant l'objet de la réclamation.

Consignes de sécurité

- Ne pas laisser les matériaux d'emballage comme les sachets en film flexible à la portée des enfants. Veuillez conserver les matériaux d'emballage hors de la portée des enfants.
- Utilisez un chiffon doux non pelucheux ou une peau de chamois pour l'entretien de vos meubles. Essuyez la surface avec un chiffon/une peau de chamois légèrement humide.
- Ne pas utiliser de chiffons en microfibras, de gomme nettoiyante ni de produits chimiques agressifs.

Nederlands

Bestellen van vervangingsonderdelen

Indien onderdelen ontbreken of beschadigd zijn, gelieve bij de bestelling absoluut de naam van de onderdelen op te geven. Gelieve voor een snelle afhandeling een kopie van de tweede bladzijde naar onze klantendienst te sturen, waarop u het onderdeel aankruist waarmee een probleem is.

Veiligheidsinstructies

- Verpakkingsmateriaal, zoals bv. foliezakjes, hoort niet in kinderhanden.

Bewaar het verpakkingsmateriaal buiten bereik van kinderen.

- Gebruik voor het onderhoud van uw meubelstuk bij voorkeur een zachte, pluisvrije doek of een zeemleer. Wrijf het oppervlak lichtelijk vochtig af.
- Gebruik geen microvezeldoeken, speciale reinigingssponzen of scherpe chemische substanties.

ESPAÑOL

Pedido de piezas de repuesto

En el caso de que alguna pieza presente fallos o esté dañada, es imprescindible indicar en el pedido la denominación de la misma. Para que la tramitación del pedido sea rápida, envíe por favor una copia de la segunda página donde ha marcado la pieza a reclamar a nuestro servicio de atención al cliente.

Instrucciones de seguridad

- Los materiales de embalaje como p.ej. las bolsas de plástico no son juguetes. Mantenga los materiales de embalaje fuera del alcance de los niños.
 - Utilice preferentemente para el cuidado de sus muebles un paño suave y que no deje pelusas o un paño de cuero.
- Limpie la superficie con el paño ligeramente humedecido.
- No utilice paños de microfibra, quitamanchas o sustancias químicas abrasivas.



Dansk

Reservedelsbestilling

Såfremt dele mangler eller er beskadigede, bedes De angive delbetegnelsen ved bestillingen. For en hurtig behandling bedes De sende en kopi af side 2 til vores kundeservice, hvorpå De har afkrydset den reklamerede del.

Sikkerhedshenvisninger

- Emballagemateriale som f.eks. folieposer må ikke komme i hænderne på børn. Emballagemateriale bør opbevares utilgængeligt for børn.
- Til pleje af møblet bør De helst anvende en blød, ikke-fnuggende klud eller et vaskeskind.

Overfladen tørres let fugtigt af.

- Anvend ikke mikrofiberklude, snavsfjerner eller stærke, kemiske stoffer.

Hrvatski

Naručivanje rezervnih dijelova

Ako dijelovi nedostaju ili su oštećeni, kod naručivanja obavezno navedite oznaku dijela. Za brzu obradu pošaljite kopiju druge stranice našoj Službi za korisnike na kojoj je križicom označen reklamirani dio.

Sigurnosne upute

- Ambalažni materijal (vrećica od folije) mora se držati podalje od djece. Stoga ga držite izvan dohvata djece.
- Za čišćenje namještaja upotrijebite mekanu krpicu koja ne ostavlja dlačice ili kožnatu krpicu.

Obrišite površinu malo navlaženom krpom.

- Nemojte koristiti krpe s mikrovlaknima, uklanjače prljavštine ni druge kemijski agresivne tvari.

Italiano

Ordine di pezzi di ricambio

Qualora manchino, o siano danneggiati, dei pezzi, specificare il nome del pezzo all'ordine. Per un rapido svolgimento, si prega di inviare una copia della seconda pagina al nostro Servizio Clienti, barrando il pezzo in questione.

Avvertenze di sicurezza

- Tenere il materiale di imballaggio, quale per esempio sacchetti di plastica, fuori dalla portata dei bambini. Conservare il materiale di imballaggio fuori dalla portata dei bambini.

- Per pulire il mobile, utilizzare un panno che non lascia pelucchi o un panno in pelle.

Asciugare la superficie con un panno leggermente inumidito.

⚠ Non usare panni in microfibra, gomme per lo sporco, o sostanze chimiche aggressive.

Polski

Zamówienie na części zamienne

W przypadku braku części lub ich uszkodzeń w zamówieniu proszę koniecznie podać oznaczenie części. W celu szybkiej realizacji reklamacji proszę przesłać do działu obsługi klienta kopię drugiej strony z zakreśloną reklamowaną częścią.

Wskazówki dotyczące bezpieczeństwa

- Materiałów opakowaniowych, np. worków foliowych, nie wolno dawać dzieciom. Materiały opakowaniowe należy trzymać w miejscu niedostępnym dla dzieci.
- Do pielęgnacji mebla najlepiej używać miękkiej, niepylącej ściereczki lub irchy.

Wycierać powierzchnię lekko zwilżoną ściereczką.

- Nie stosować ściereczek z mikrofibry, gąbek do czyszczenia brudu ani silnie działających substancji chemicznych.

Slovensky

Objednávania náhradných dielov

Ak by diely chýbali alebo boli poškodené, pri objednávaní bezpodmienečne uveďte označenie dielu. Pre rýchlejšie vybavenie pošlite kópiu druhej strany nášmu zákazníkemu servisu, na ktorej reklamovaný diel označíte križikom.

Bezpečnostné pokyny

- Obalový materiál, ako napr. fóliové vrečky, nepatrí do rúk deťom. Obalový materiál uschovajte mimo dosahu detí.
- Na ošetrovanie nábytku použite najlepšie mäkkú handru, ktorá nepúšťa vlákna, alebo koženú utierku.

Povrch utrite jemne navlhčenou handrou.

- Nepoužívajte utierky z mikrovlákná, čistiace gumy a agresívne chemické látky.

SLOVENŠČINA

Naročilo nadomestnih delov

Če deli manjkajo ali so poškodovani, ob naročilu nujno navedite tudi opis dela. Za hitro obdelavo zahtevka naši službi za stranke pošljite kopijo druge strani, na kateri označite reklamirani del.

Varnostni napotki

- Embalažni material, kot so plastične vrečke, ne spadajo v roke otrok. Embalažni material shranjujte zunaj dosega otrok.
- Za nego svojega pohištva uporabite mehko krpo, ki se ne kosmati, ali usnjeno krpo.

Površine obrišite z rahlo navlaženo krpom.

- Ne uporabljajte krp iz mikrovlaknen, čistilnih radirk in močnih kemičnih sredstev.



ENGLISH

Important information
Read carefully.
Keep this information for further
reference.

WARNING

Serious or fatal crushing injuries
can occur from furniture tip-over. To
prevent this furniture from tipping
over it must be permanently fixed to
the wall.

DEUTSCH

Wichtige Information
Sorgfältig lesen
Diese Information aufbewahren

ACHTUNG

Wenn Möbelstücke umkippen, kön-
nen ernste oder lebensgefährliche
Verletzungen durch Einklemmen die
Folge sein.

Um zu verhindern, dass das Möbel-
stück umkippt, muss es fest an der
Wand verankert werden.

SVENSKA

Viktig information
Läs noga
Spara informationen för framtida
bruk

VARNING

Allvarliga eller livsfarliga klämska-
dor kan ske om möbler tippas över.
För att förhindra att den här
möbeln tippas måste den fästas
permanent vid väggen.

FRANÇAIS

Information importante
A lire attentivement.
Conserver ces informations pour un usage
ultérieur.

AVERTISSEMENT

Risque de blessure grave en cas de
chute du meuble. Pour éviter que le
meuble ne bascule, il faut le fixer au
mur de façon permanente.

NEDERLANDS

Belangrijke informatie Goed lezen
Bewaar deze informatie voor
toekomstig gebruik

WAARSCHUWING

Wanneer meubels omvallen, kan er
ernstig of levensbedreigend be-
klemmingsletsel ontstaan.

Om te voorkomen dat dit meubel
omvalt, dient dit permanent aan
de wand te worden bevestigd.

ESPAÑOL

Información importante
Leer detenidamente.
Guarda esta información para
consultarla en el futuro.

ADVERTENCIA

Pueden producirse lesiones graves
o fatales si vuelca un mueble. Para
evitar que vuelque este mueble, debe
fijarse permanentemente a la
pared.

DANSK

Vigtige oplysninger!
Læs omhyggeligt.
Gem disse oplysninger til senere
brug.

ADVARSEL!

Der kan opstå alvorlig eller livsfarlig
tilskadekomst, hvis møblet vælter.
For at undgå at møblet vælter, skal
det fastgøres permanent til
væggen.

HRVATSKI

Važne informacije
Pažljivo pročitajte.
Sačuvajte ove upute za buduće
potrebe.

UPOZORENJE

Ako se namještaj prevrne može
doći do ozbiljnih ili smrtonosnih
ozljeda. Kako bi izbjegli prevrtanje,
namještaj mora biti pričvršćen na
zid.

ITALIANO

Informazioni
importanti. Leggi
attentamente.
Conserva queste informazioni per
ulteriori consultazioni.

AVVERTENZA

Se il mobile si ribalta può causare
lesioni da compressione serie o
fatali. Per prevenire il rischio che il
mobile si ribalti, quest'ultimo
deve essere fissato
permanentemente alla parete.

POLSKI

Ważne informacje
Przeczytaj uważnie.
Zachowaj ulotkę na przyszłość.

UWAGA

Przewrócenie się mebli może dopro-
wadzić do poważnych obrażeń lub
śmierci. Aby zapobiec przewróceniu
się mebla, należy na stałe przymo-
cować go do ściany.

SLOVENSKY

Dôležité informácie! Čítajte pozorne.
Informácie si uschovajte pre
prípád potreby.

UPOZORNENIE

Prevrhnutie nábytku môže
spôsobiť vážne či smrteľné
zranenia. Aby sa predišlo
prevrnutiu nábytku, upev-
nite ho ku stene.

SLOVENŠČINA

Pomembne informacije Pozorno
preberite.
Shranite navodila za morebitno
ponovno uporabo.

OPOZORILO

Če se pohištvo prevrne, lahko
pride do resnih telesnih poškodb.
Da bi preprečili nevarnost, da se to
pohištvo prevrne, mora biti
pritrjeno na steno.

Garantiekarte / guarantee card

Modell: CERVO

48648 WE5

#10004

/17

Bitte bei Ersatzteilbestellungen die fehlenden oder beschädigten Teile kennzeichnen.

Please mark the missing or damaged parts if you place a spare part order.

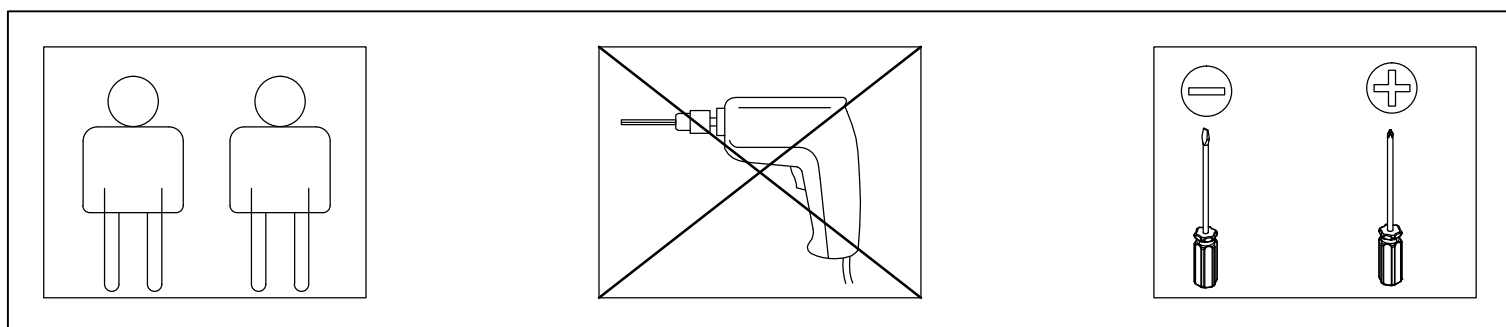
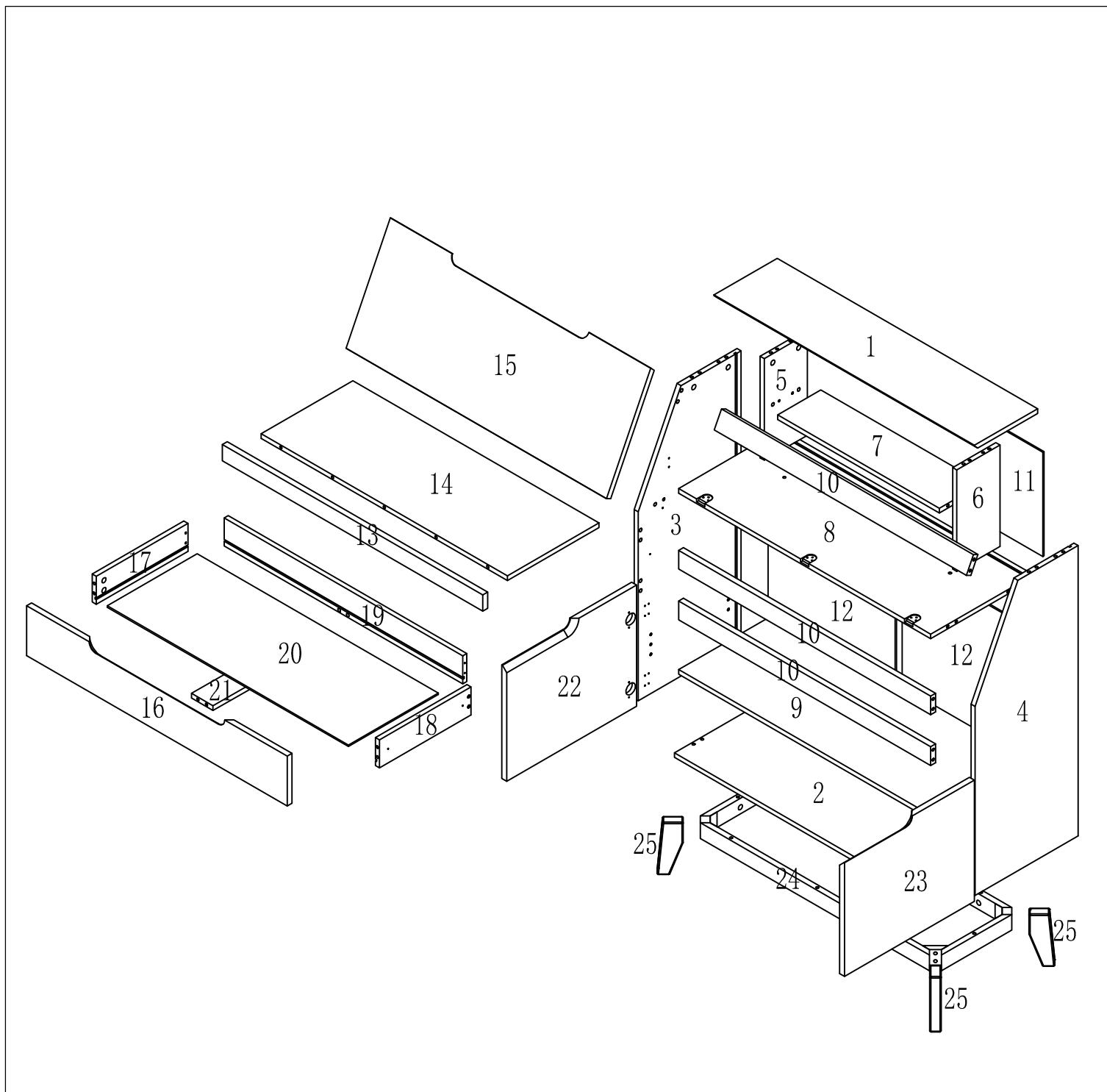

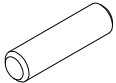
A	x 26
	
ø7.8*30mm	

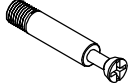
B	x 47
	
M6*36mm	

C	x 47
	
ø15*12mm	

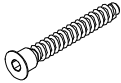
D	x 8
	
M7*50mm	

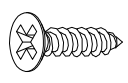
E	x 83
	
ø3.5*14mm	

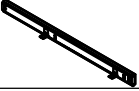
F	x 1
	
L355mm	

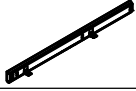
G	x 1
	
L355mm	

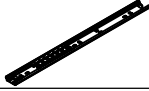
H	x 2
	
L340mm	

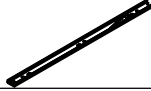
I	x 2
	
L340mm	

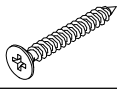
J	x 6
	
M4*35mm	

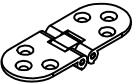
K	x 3
	
79*30*8mm	

L	x 10
	
14*14*9mm	

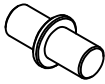
M	x 4
	
ø5*16mm	

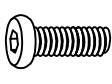
N	x 8
	
M6*30mm	

O	x 8
	
ø16*ø6.5*11mm	

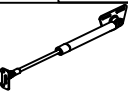
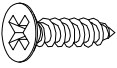
P1	x2	P2	x4
			

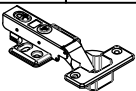
Q	x 4
	
ø35	

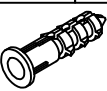
R	x 2
	
M8*40mm	

S	x 1
	
M4	

T	x 2
	
150*20*2mm	

1

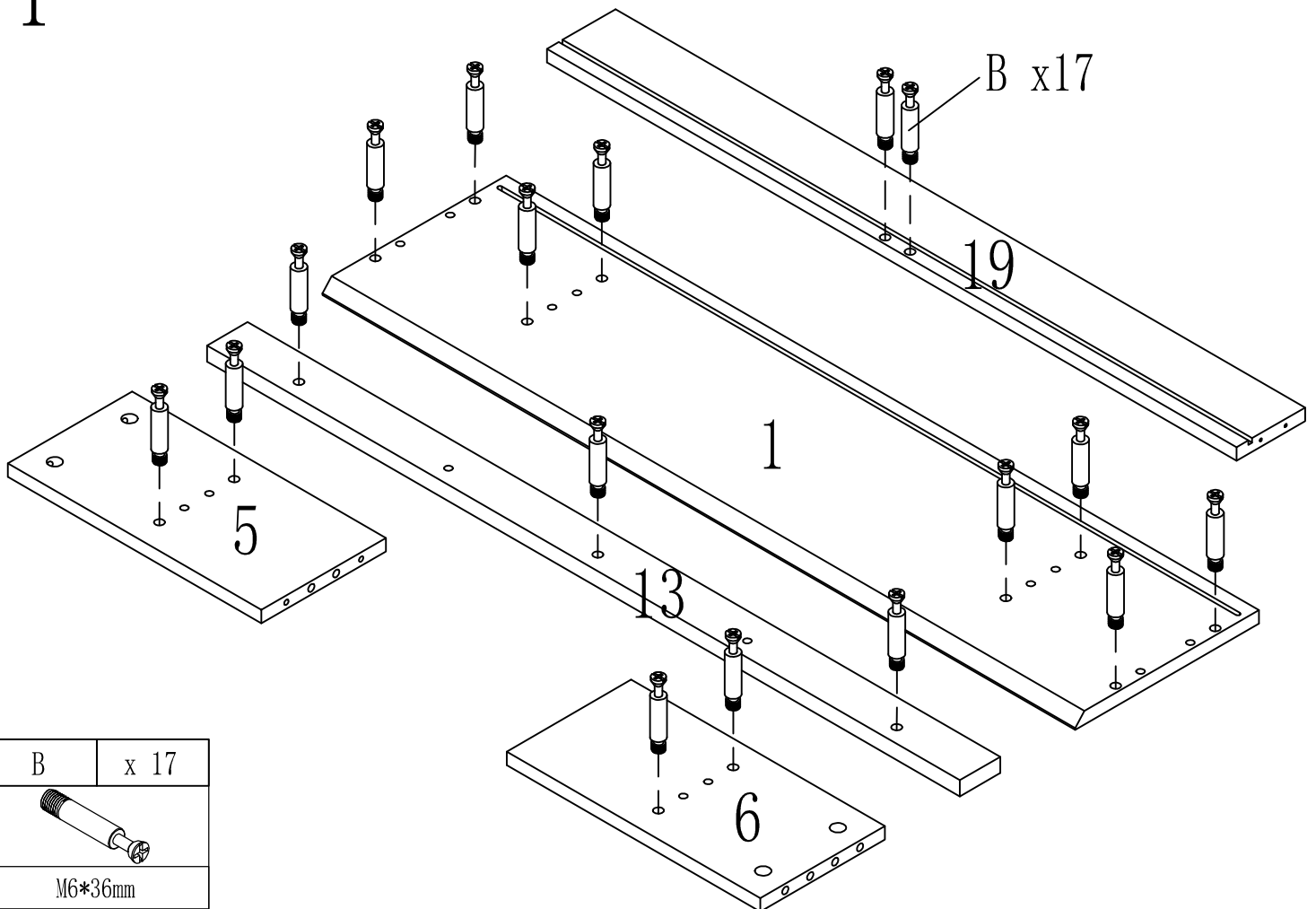

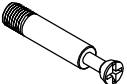
B	x 17
	
M6*36mm	

2

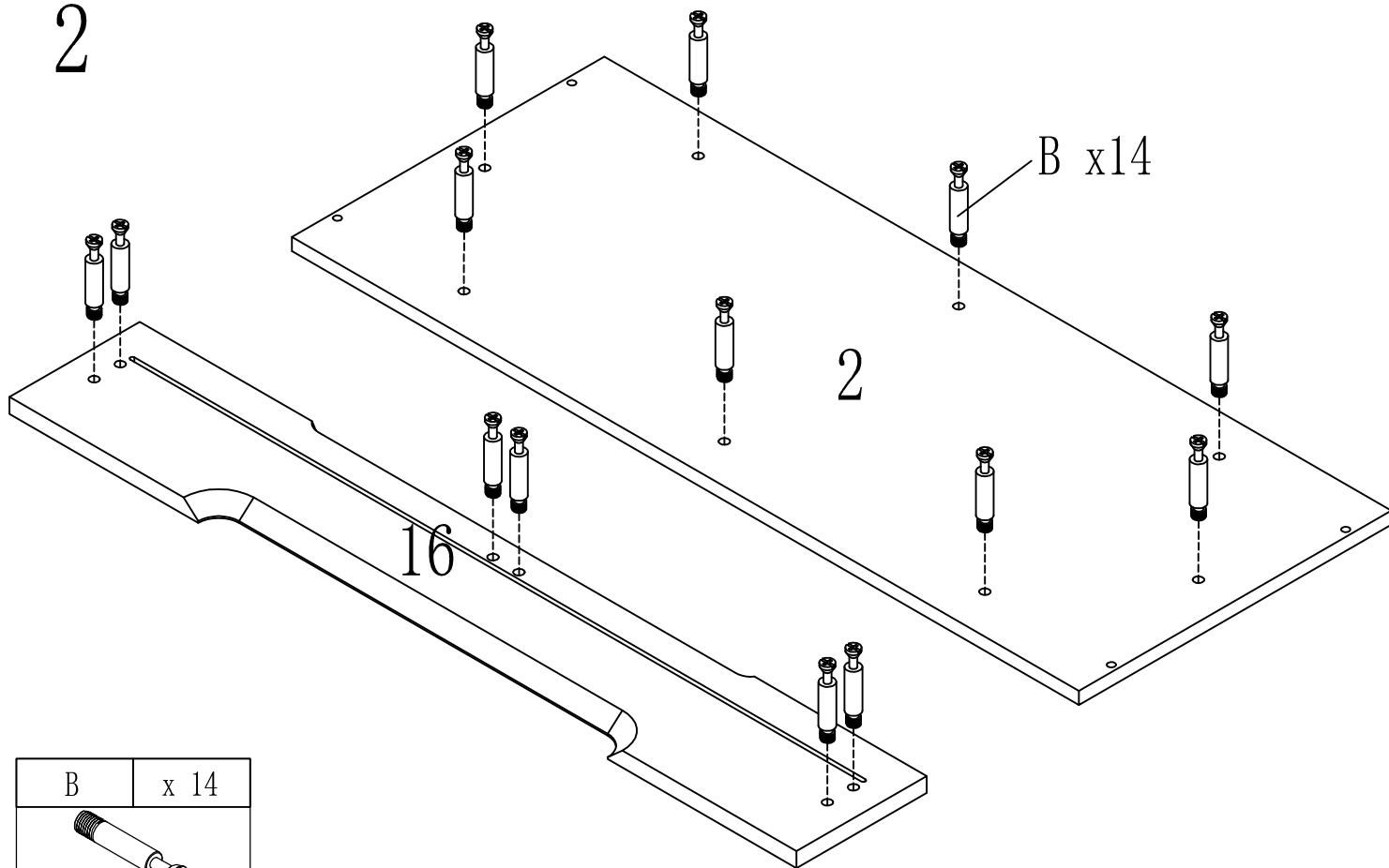

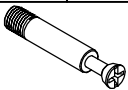
B	x 14
	
M6*36mm	

3

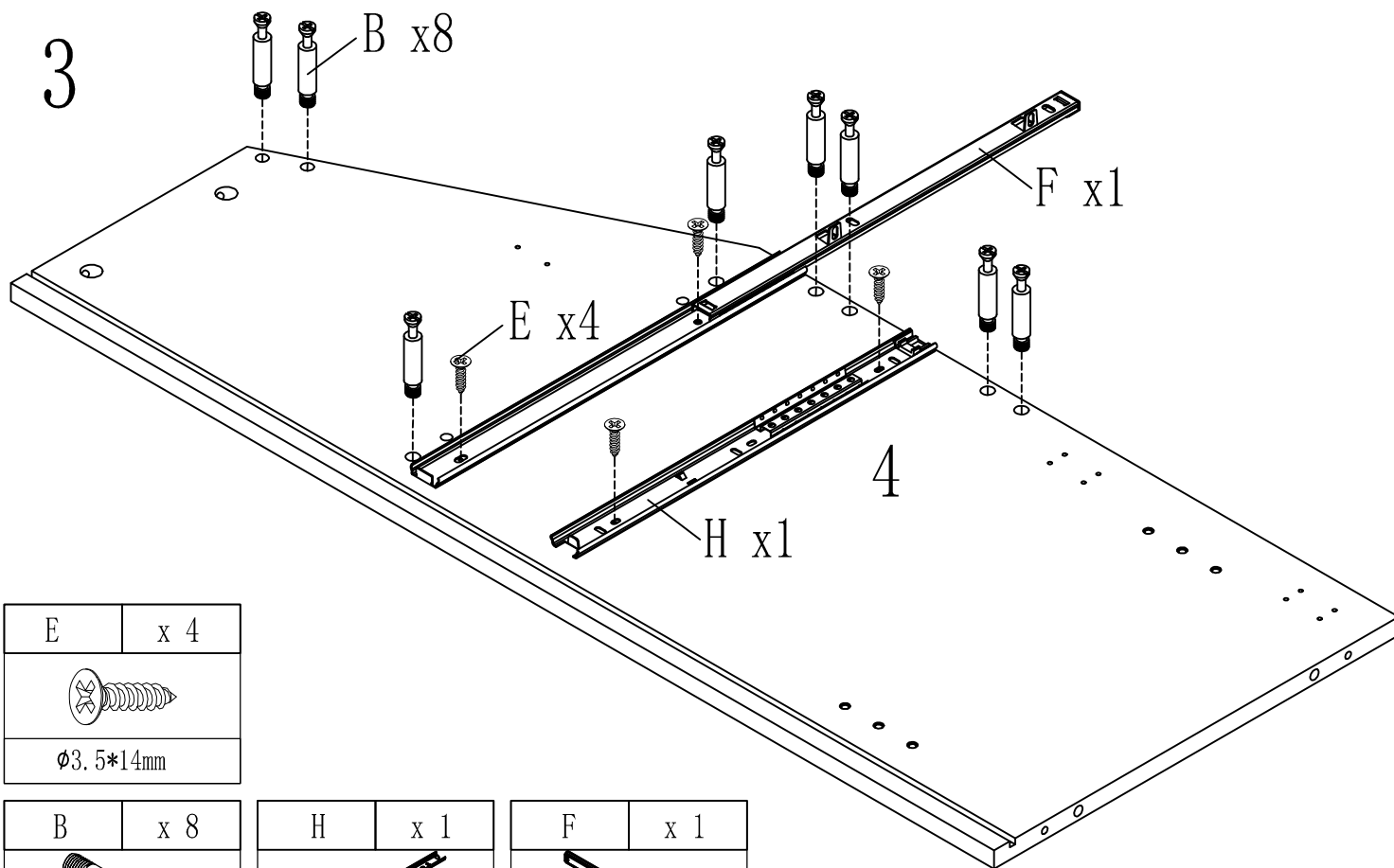

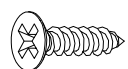
E	x 4
	
Ø3.5*14mm	

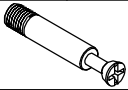
B	x 8
	
M6*36mm	

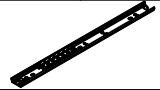
H	x 1
	
L340mm	

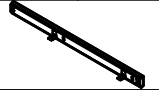
F	x 1
	
L355mm	

4

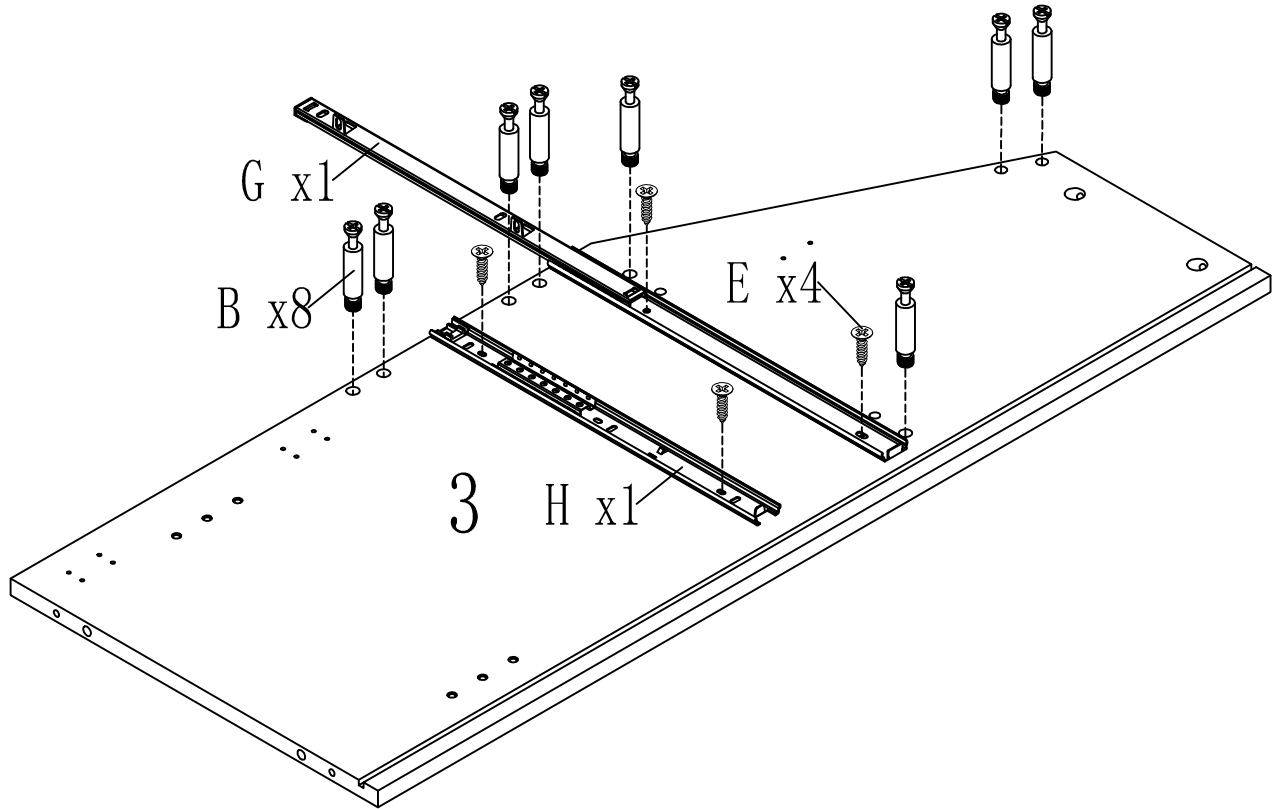

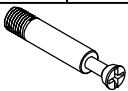
B	x 8
	
M6*36mm	

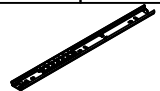
H	x 1
	
L340mm	

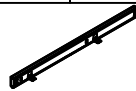
G	x 1
	
L355mm	

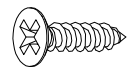
E	x 4
	
φ3.5*14mm	

5

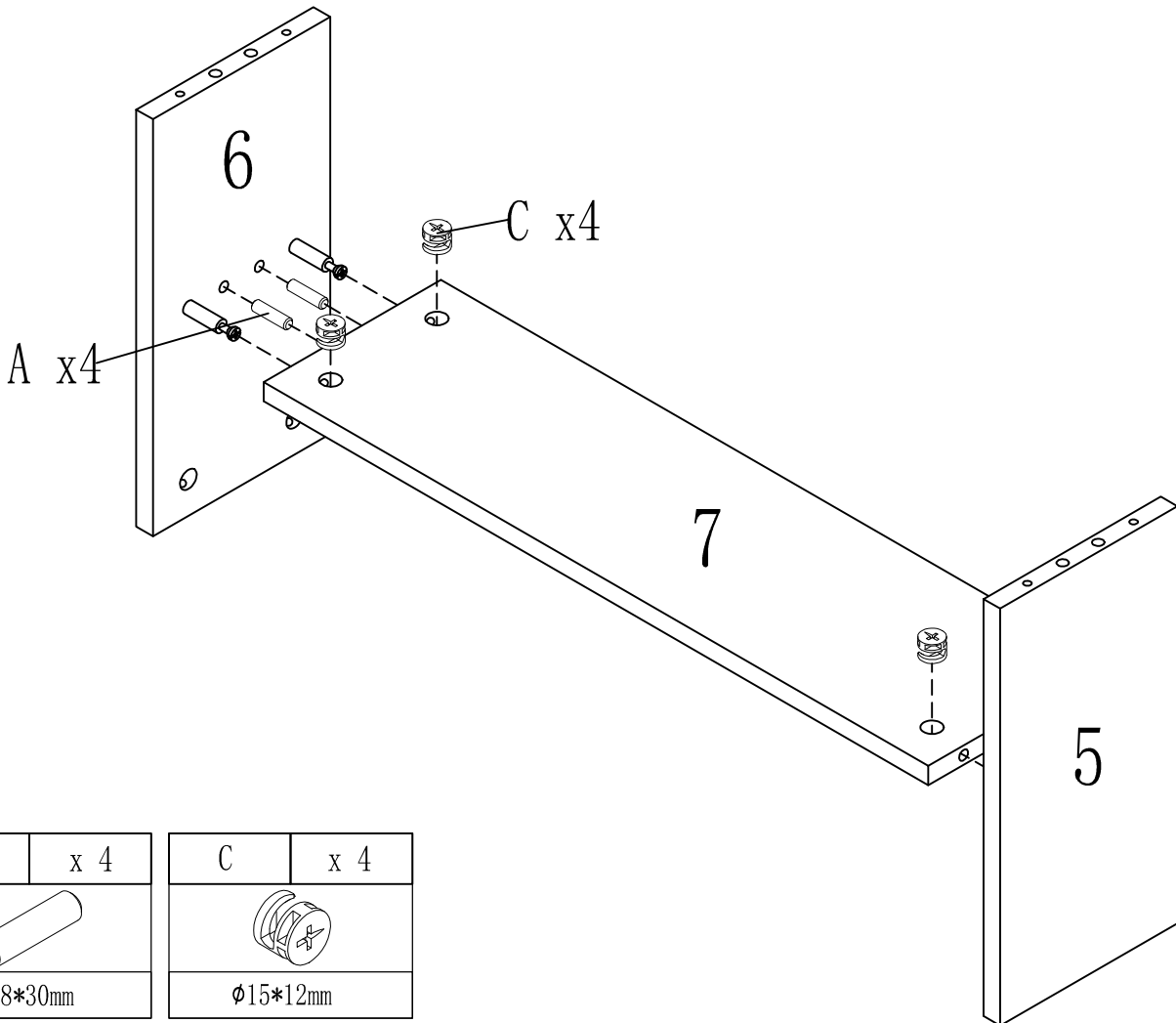

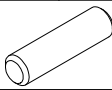

A	x 4
	
φ7.8*30mm	

C	x 4
	
φ15*12mm	

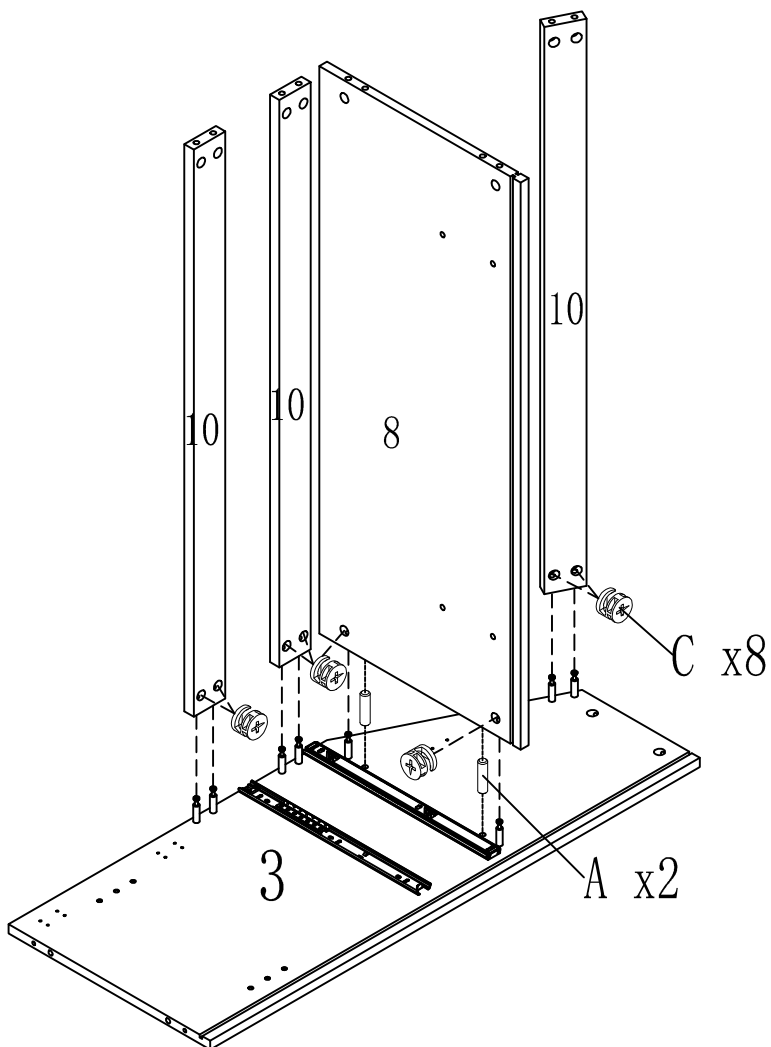
6

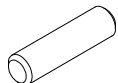



A	x 2
	
ø7.8*30mm	

C	x 8
	
ø15*12mm	

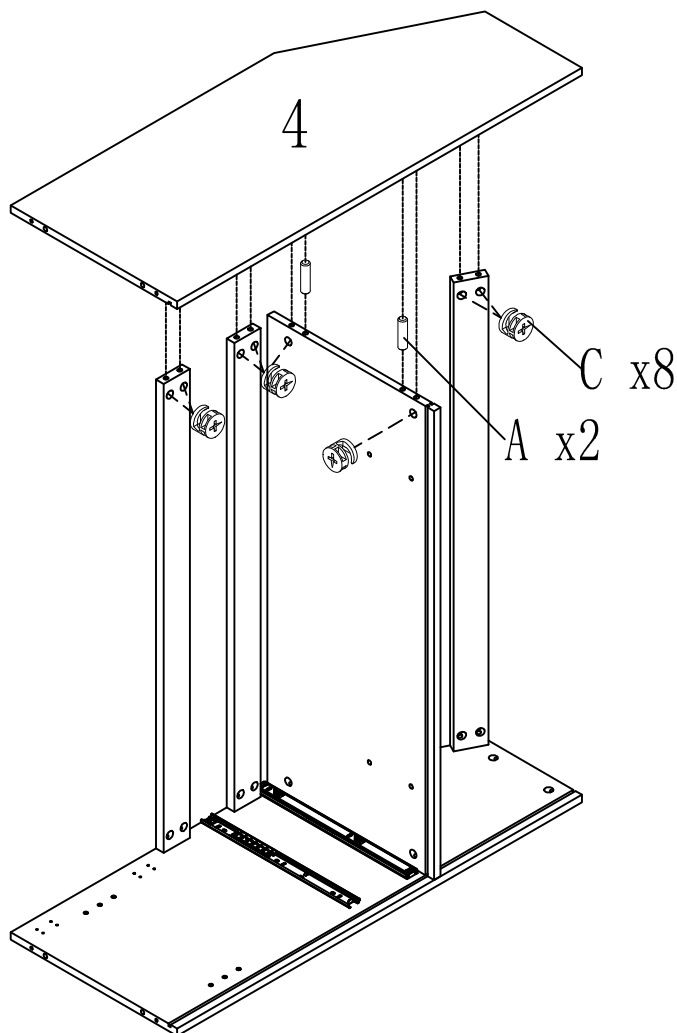
7

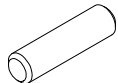

A	x 2
	
ø7.8*30mm	

C	x 8
	
ø15*12mm	

8

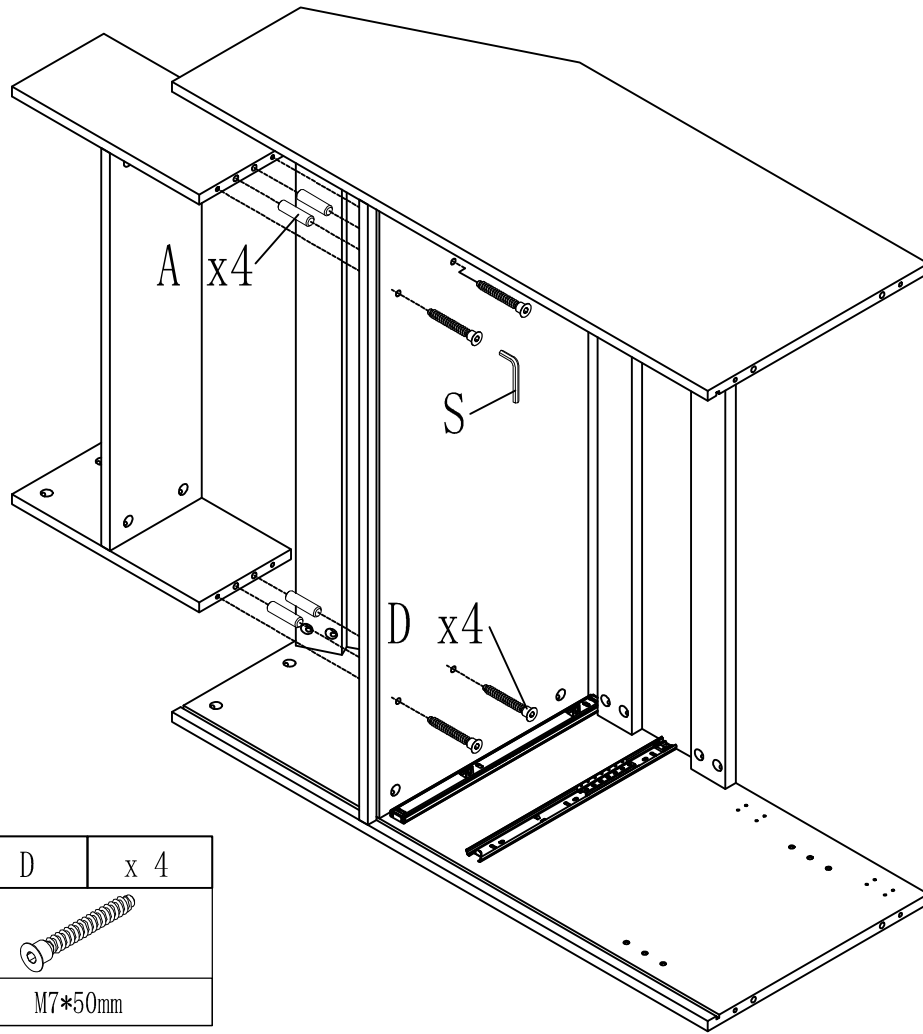

S	x 1
	
M4	

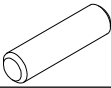
A	x 4
	
φ7.8*30mm	

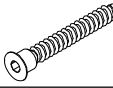
D	x 4
	
M7*50mm	

9

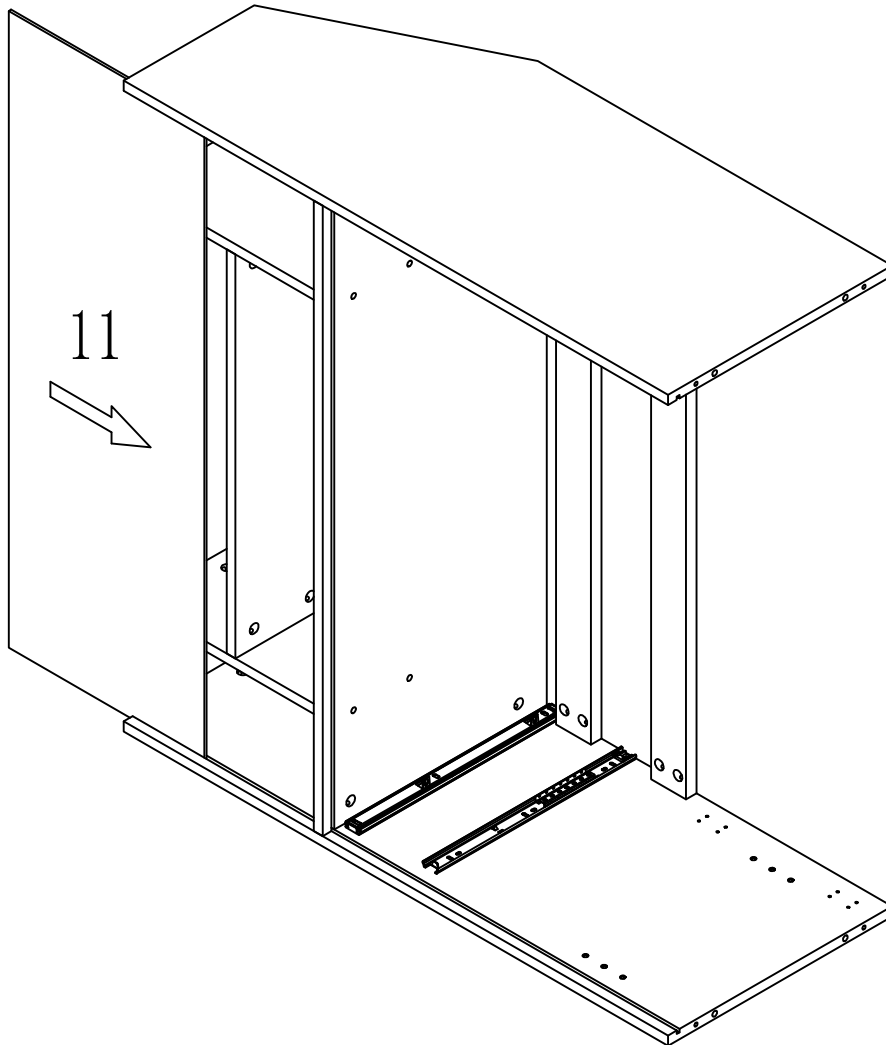

10

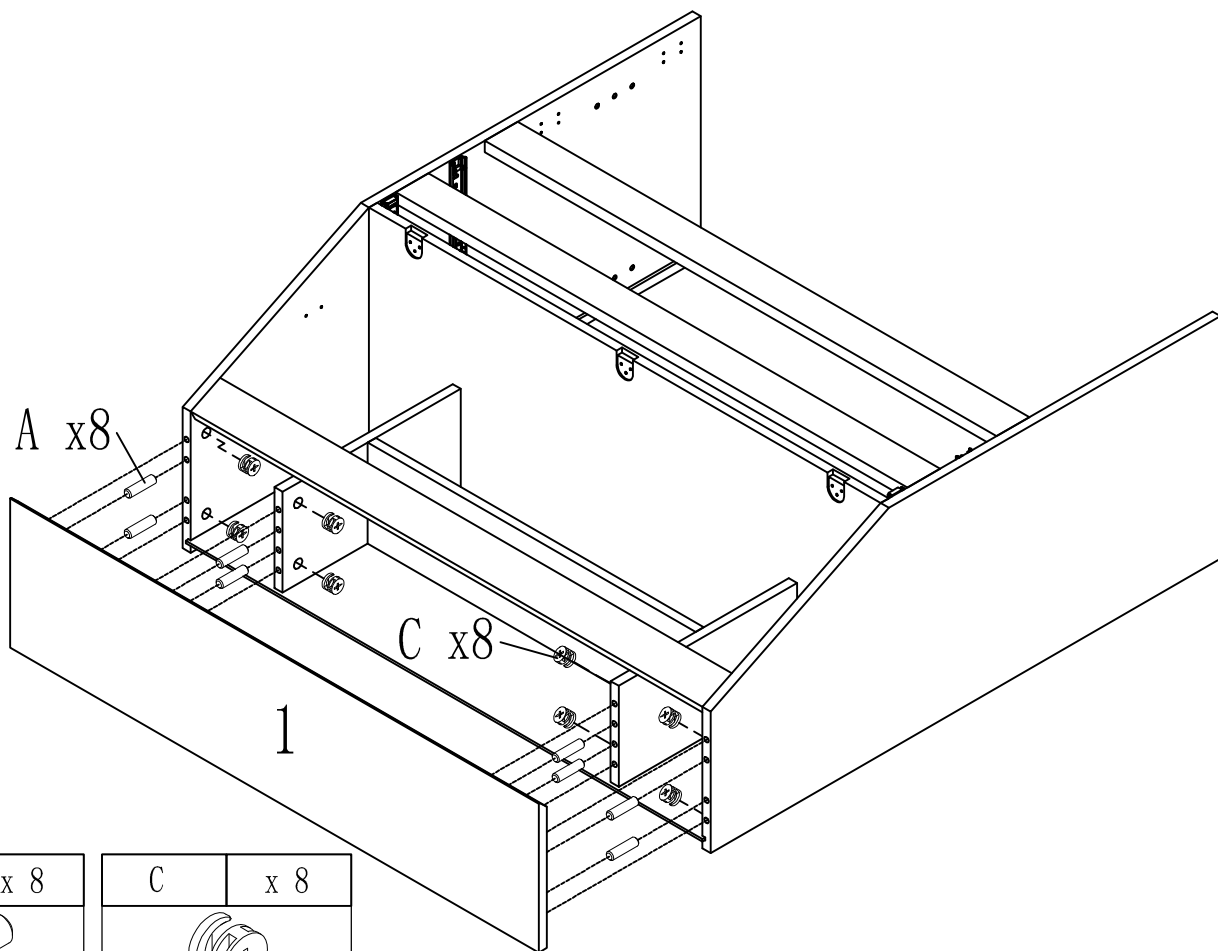

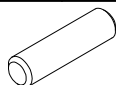
A	x 8
	
$\phi 7.8 \times 30\text{mm}$	

C	x 8
	
$\phi 15 \times 12\text{mm}$	

11

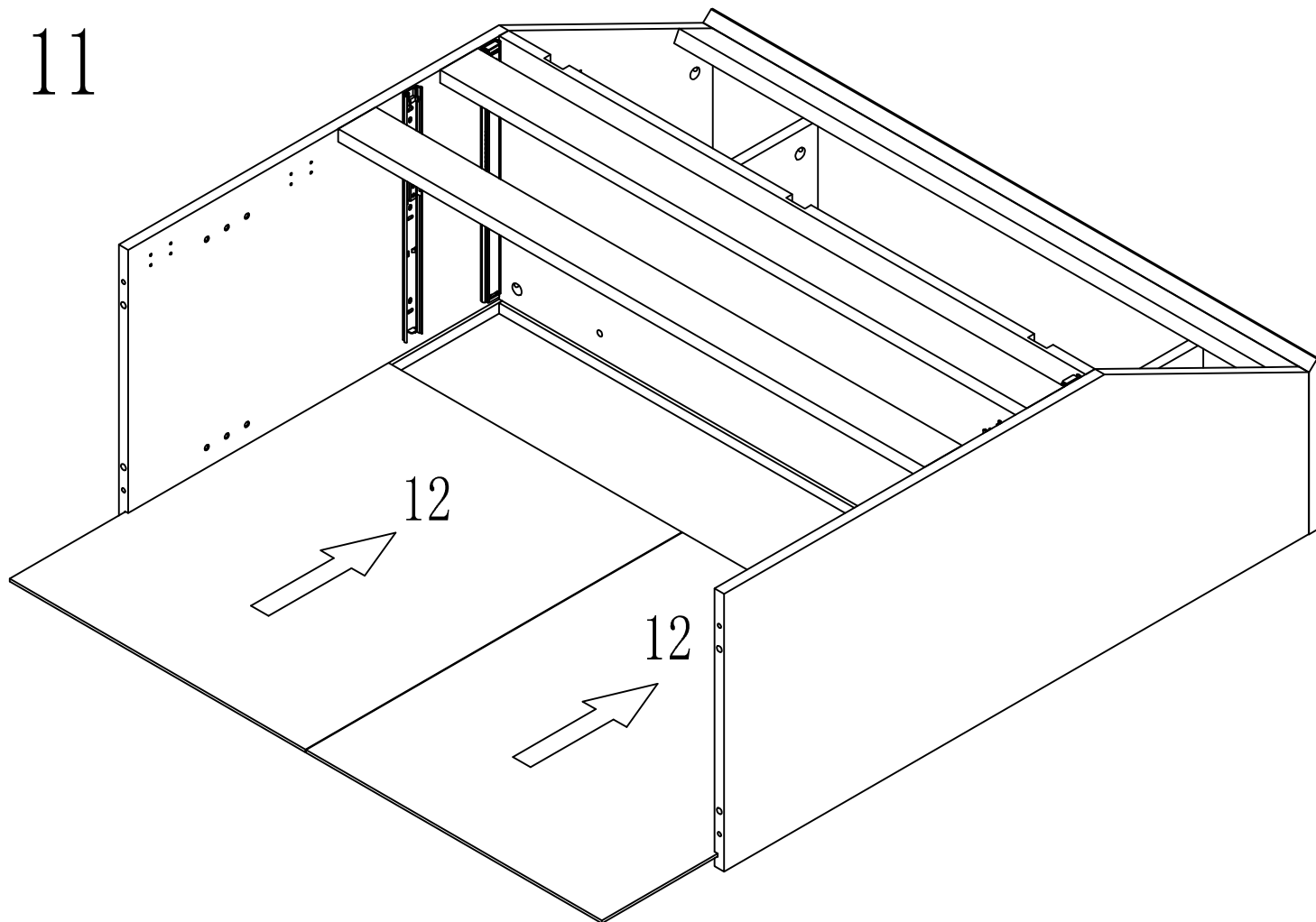

12

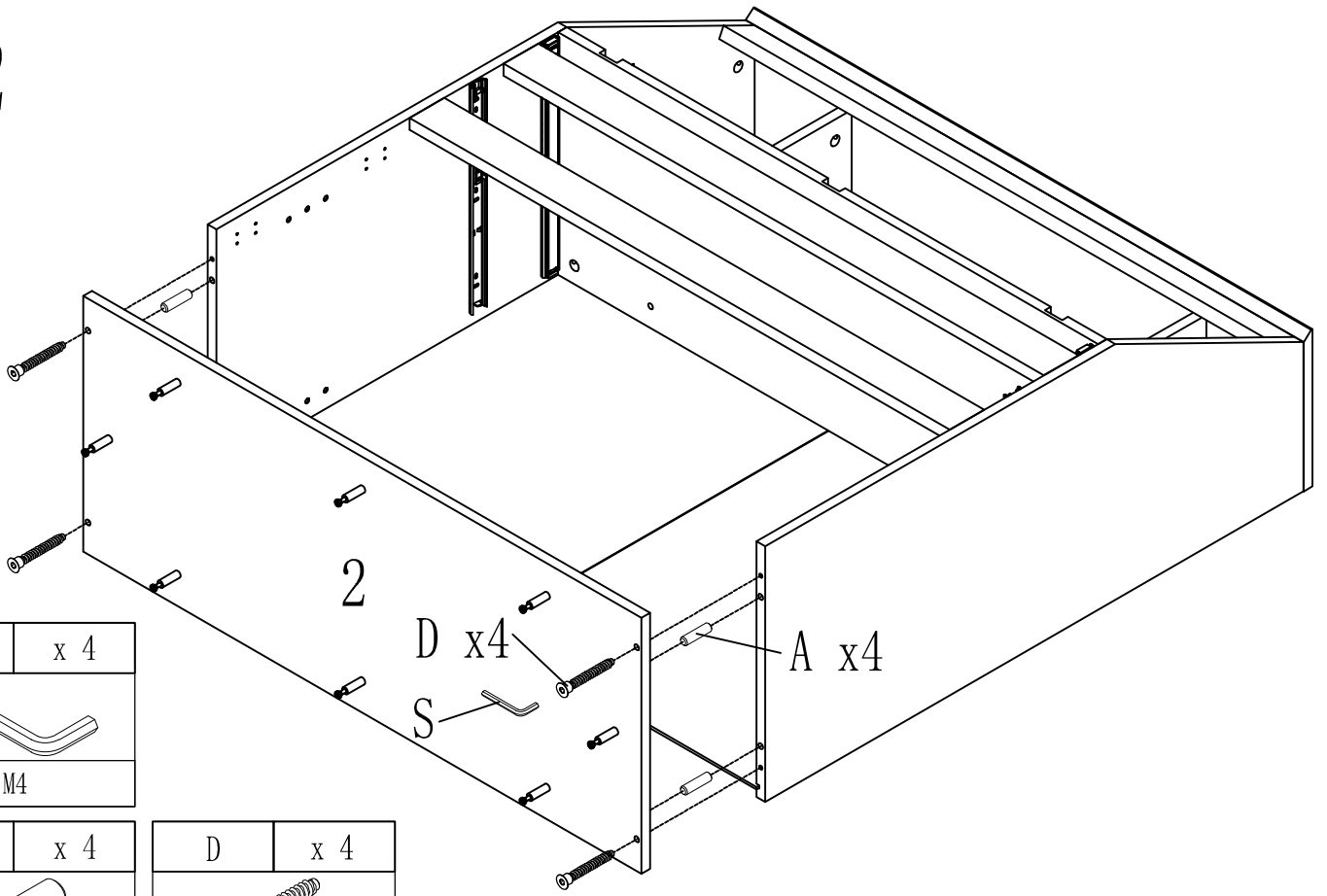

S	x 4
M4	

A	x 4
φ7.8*30mm	

D	x 4
M7*50mm	

D x4
S
A x4

13

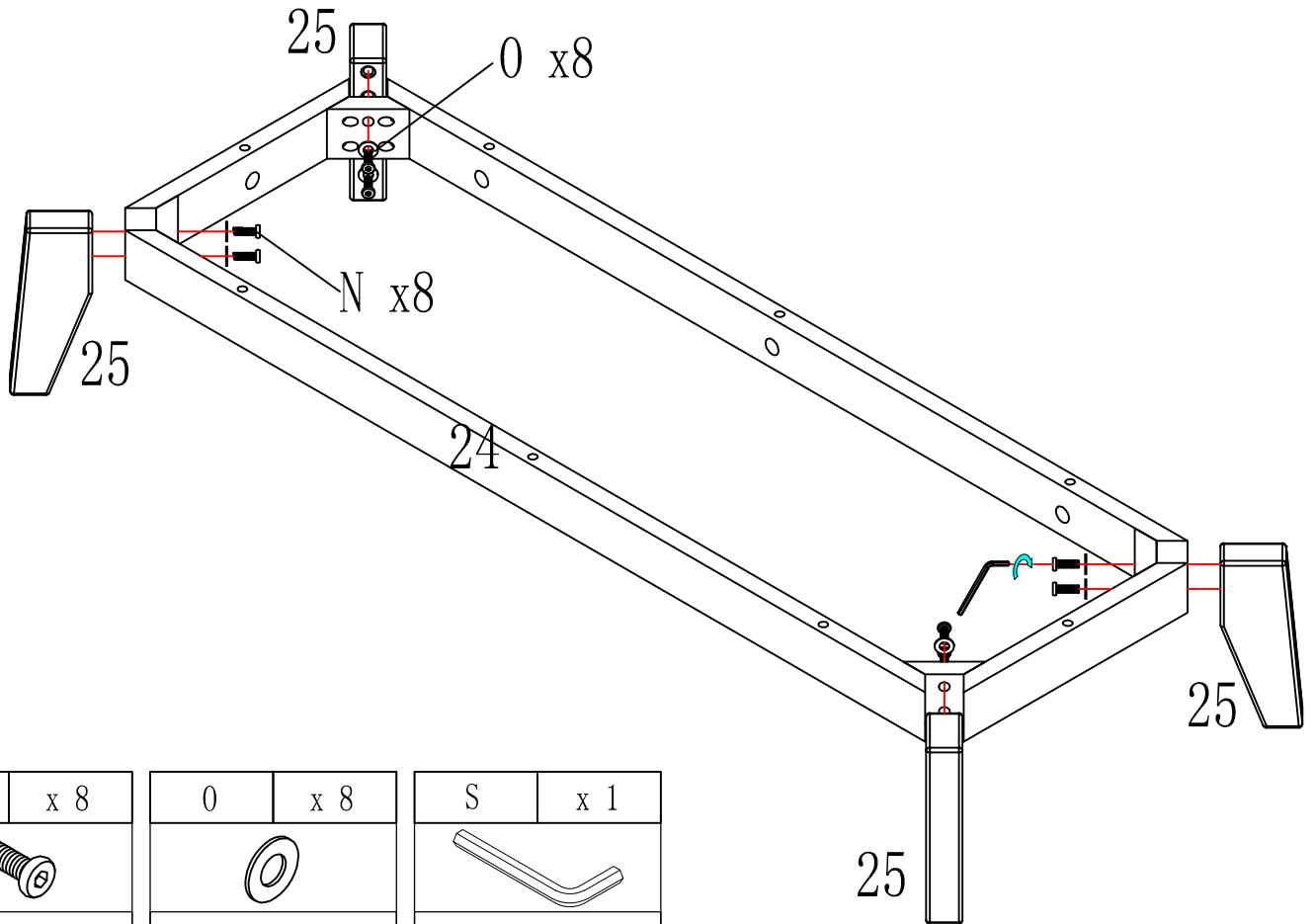

N	x 8
M6*30mm	

0	x 8
φ16*φ6.5*T1mm	

S	x 1
M4	

14

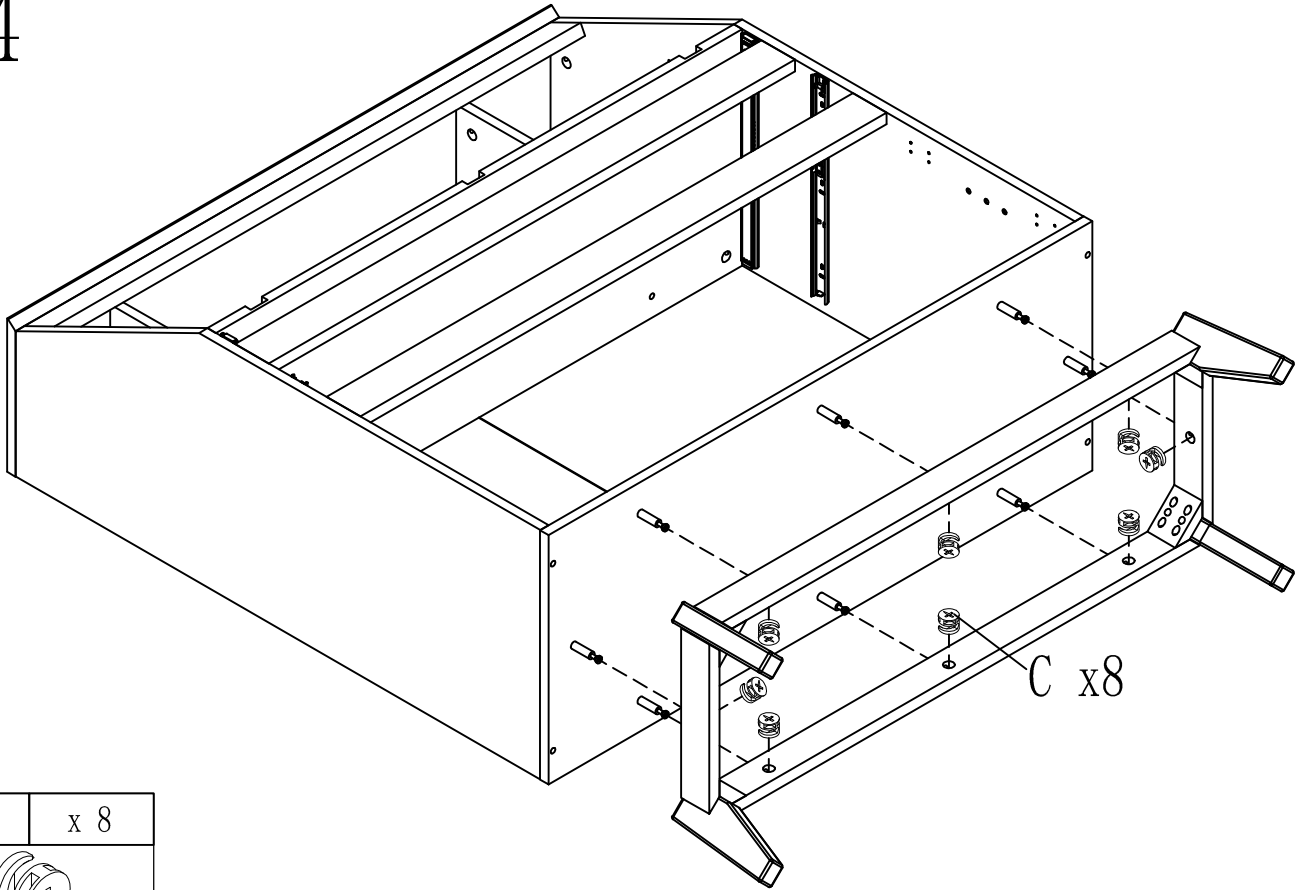

C	x 8
$\phi 15 * 12 \text{mm}$	

15

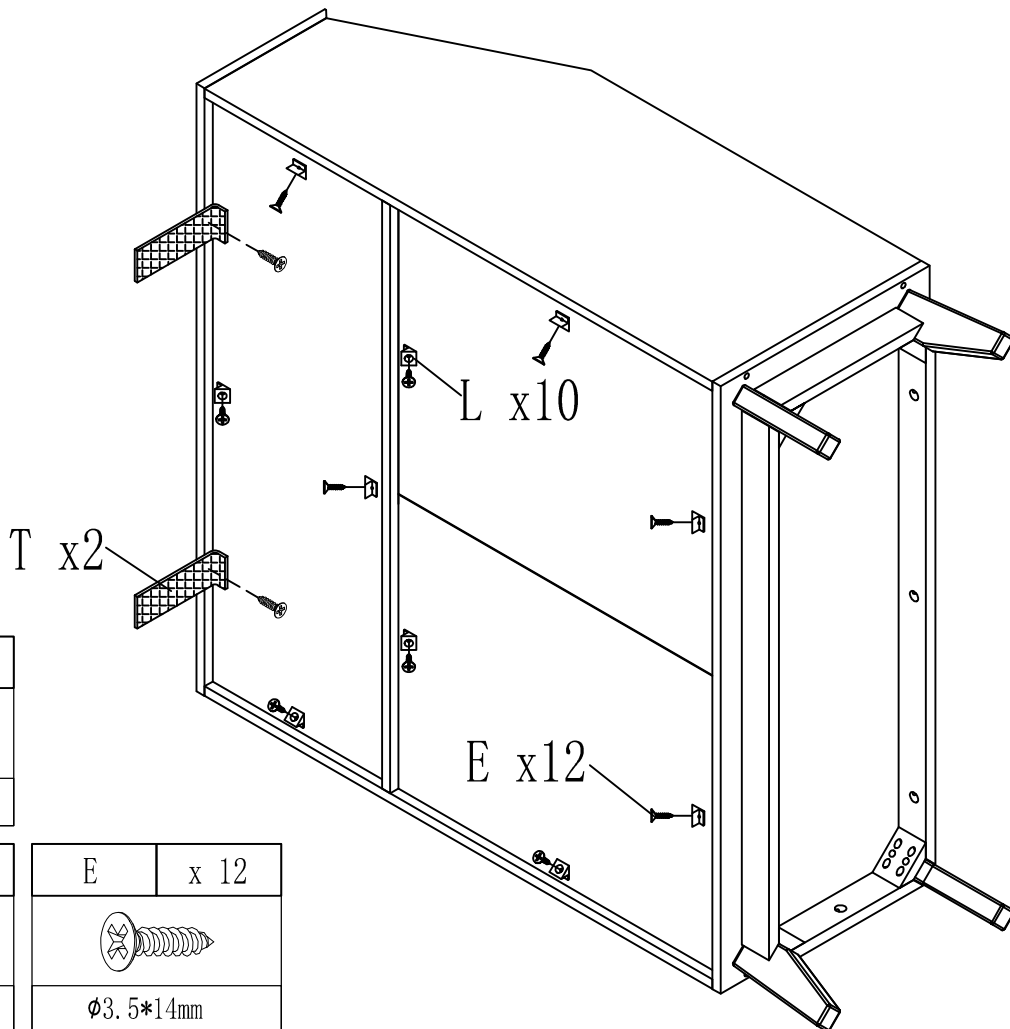

T	x 2
$150 * 20 * 2 \text{mm}$	

L	x 10
$14 * 14 * 9 \text{mm}$	

E	x 12
$\phi 3.5 * 14 \text{mm}$	

16

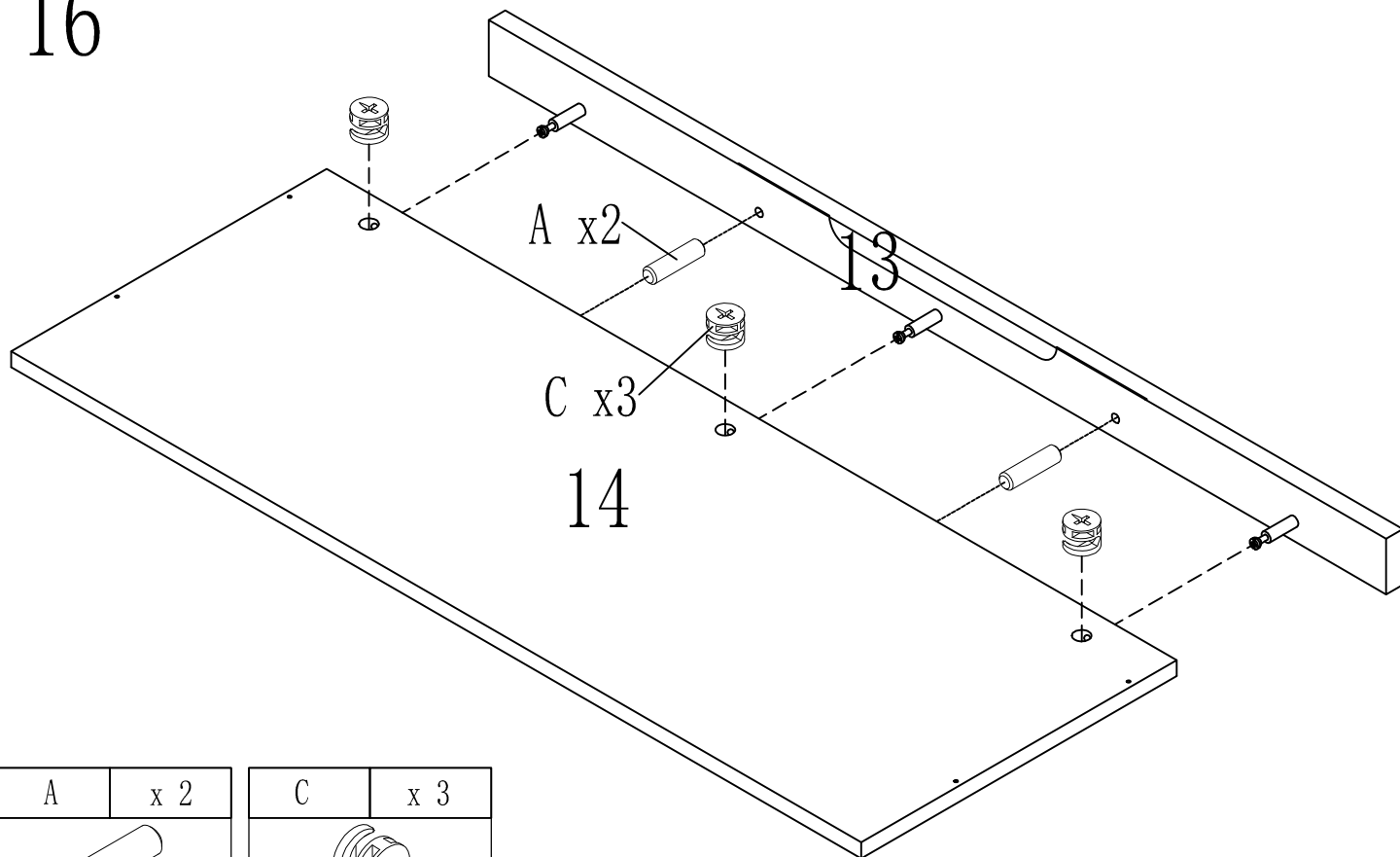

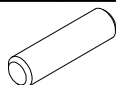
A	x 2
	
ø7.8*30mm	

C	x 3
	
ø15*12mm	

17

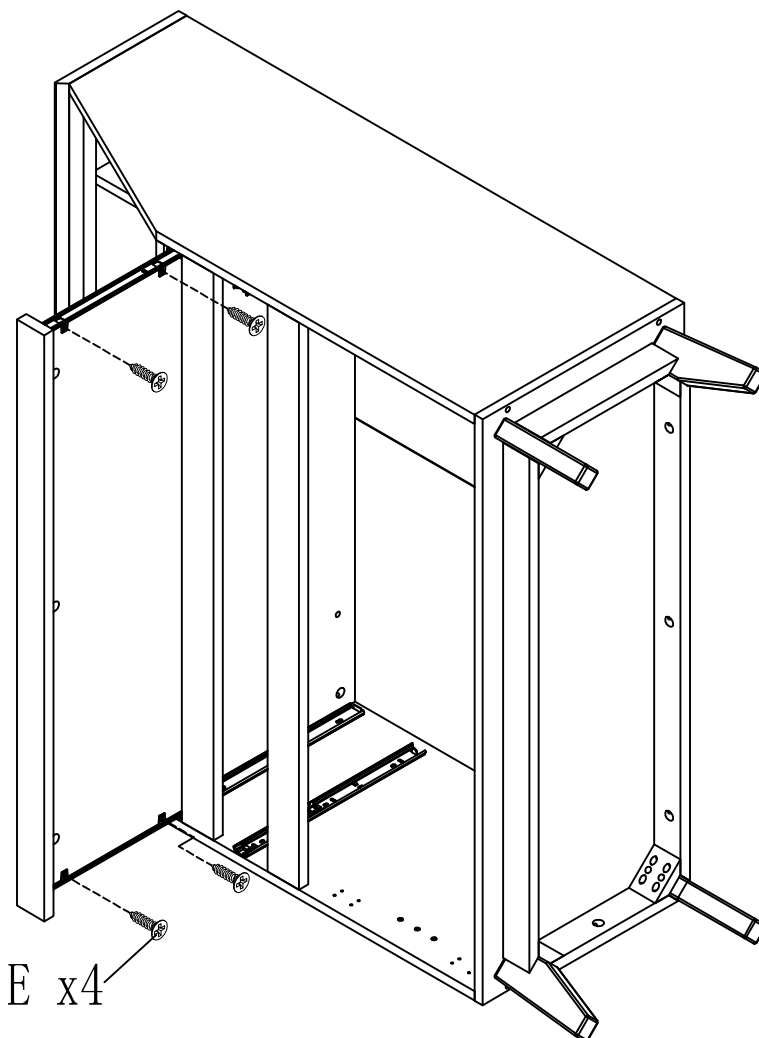

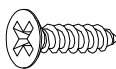
E	x 4
	
ø3.5*14mm	

18

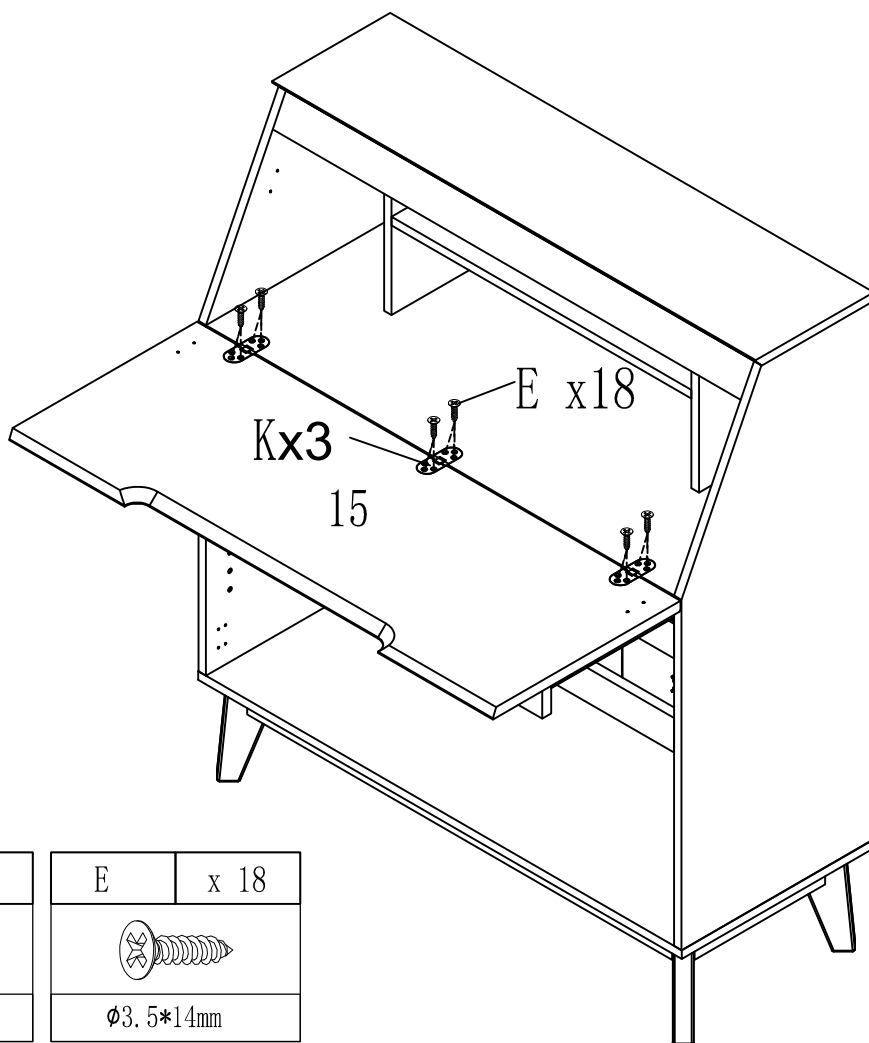

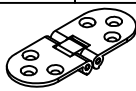
K	x 3
	
79*30*8mm	

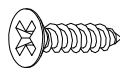
E	x 18
	
Ø3.5*14mm	

19

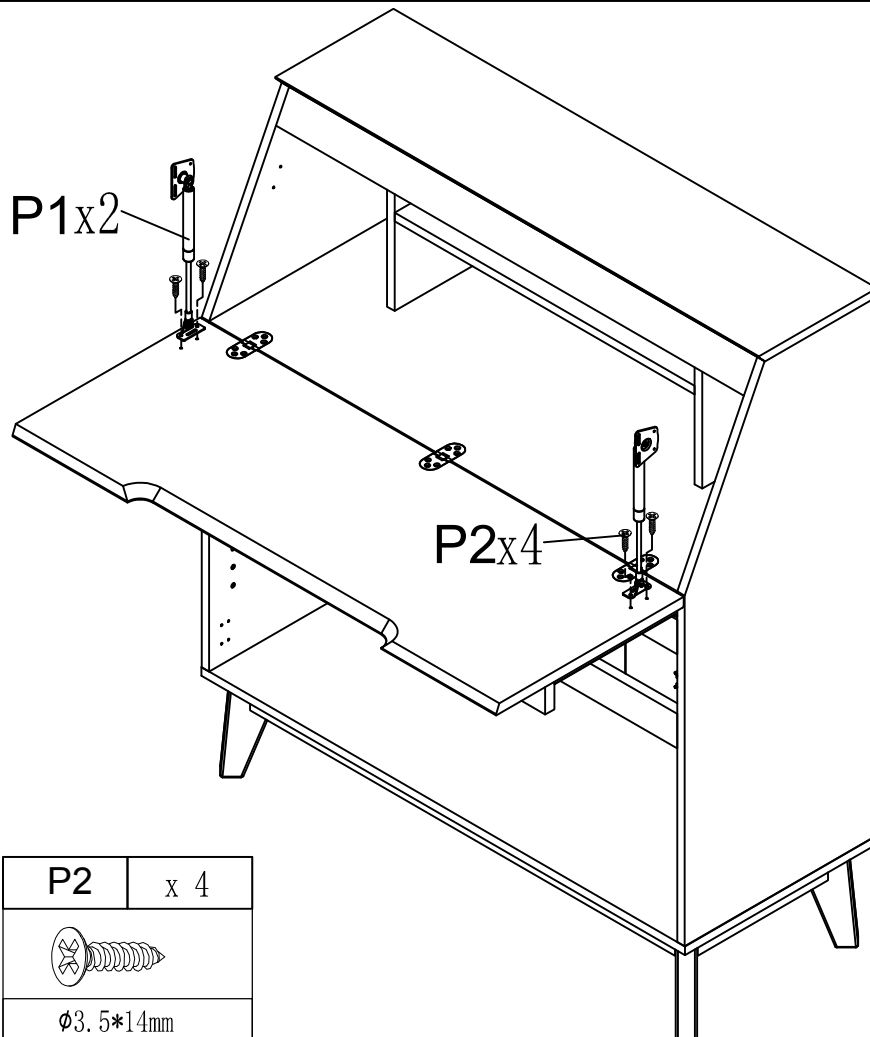

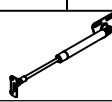
P1	x 2
	

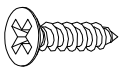
P2	x 4
	
Ø3.5*14mm	

20

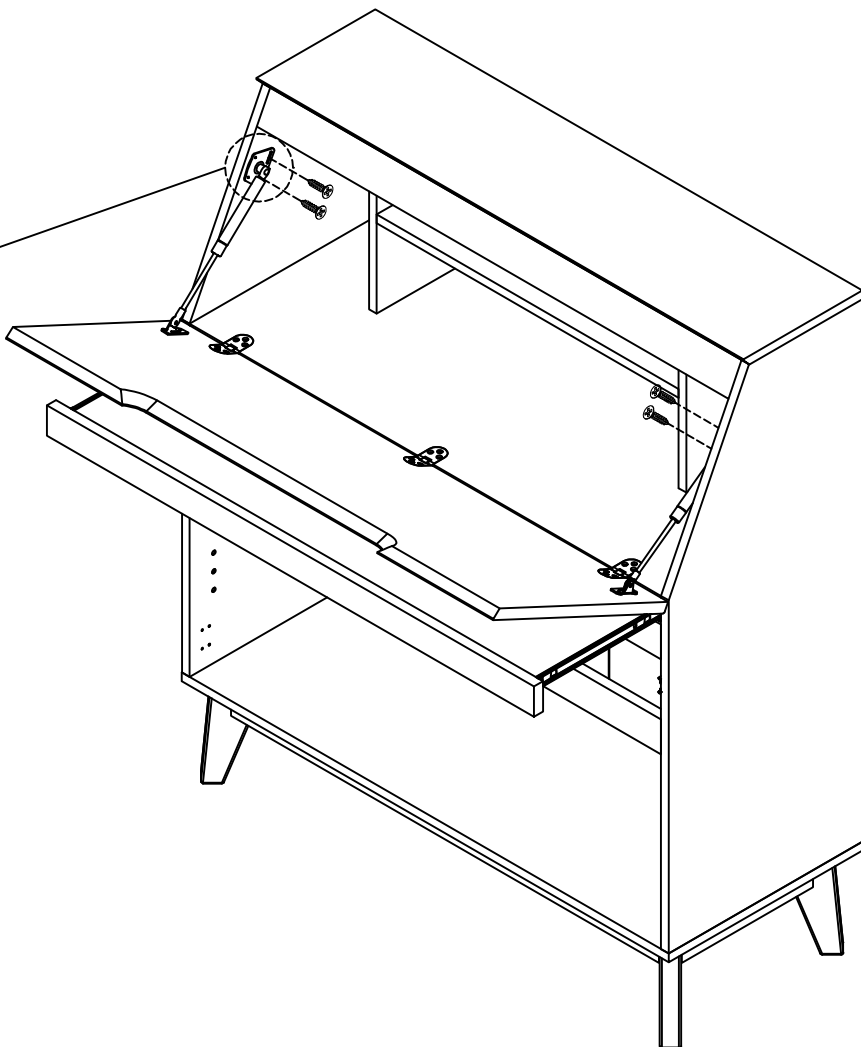
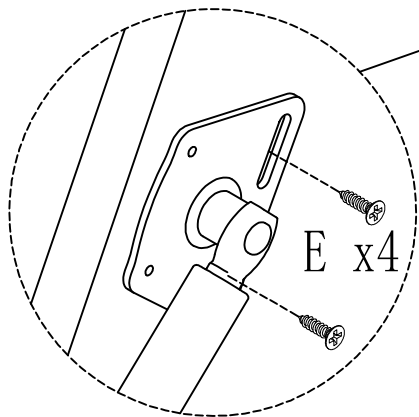

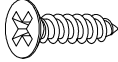
E	x 4
	
Ø3.5*14mm	

21

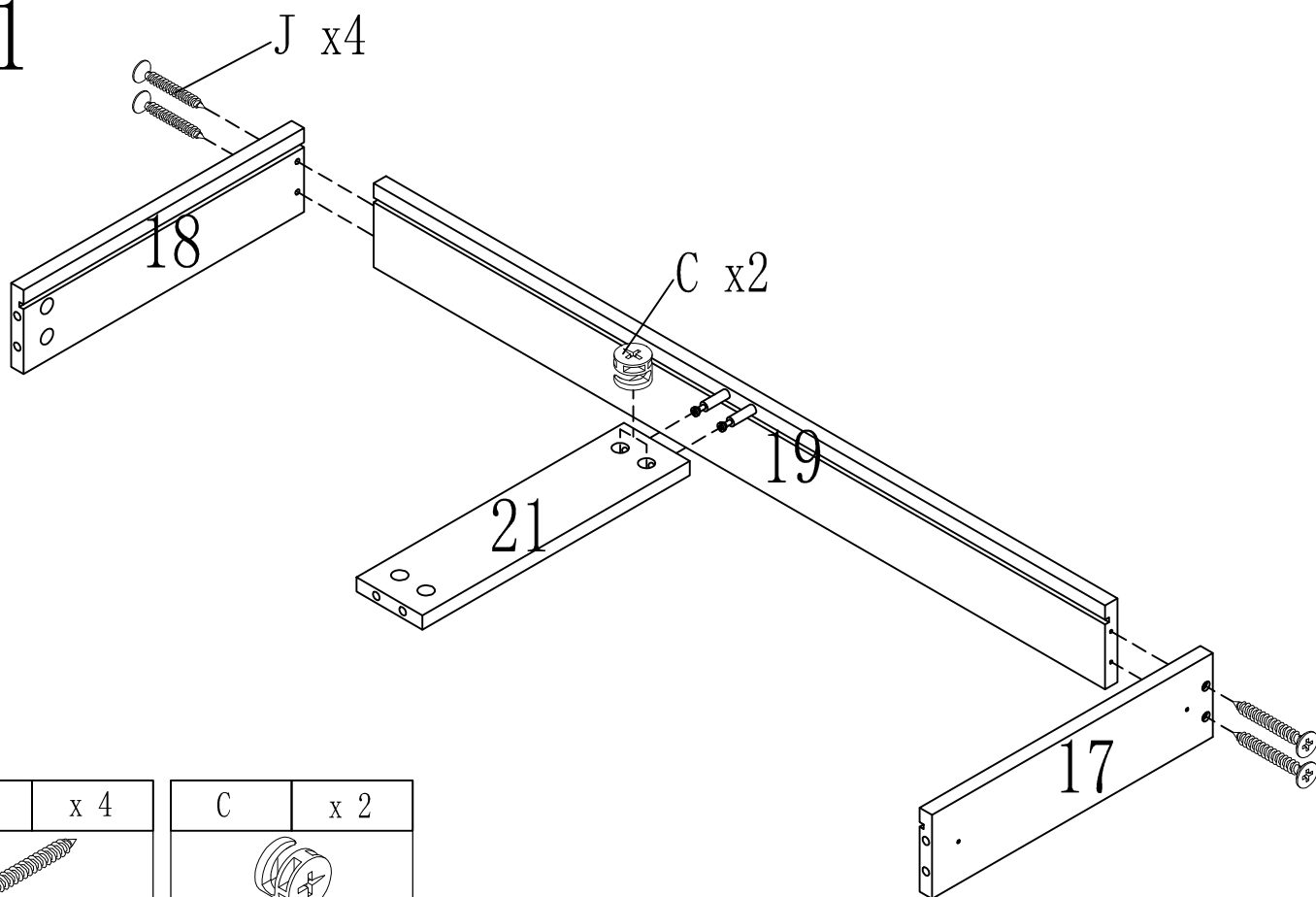

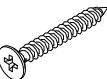
J	x 4
	
M4*35mm	

C	x 2
	
Ø15*12mm	

22

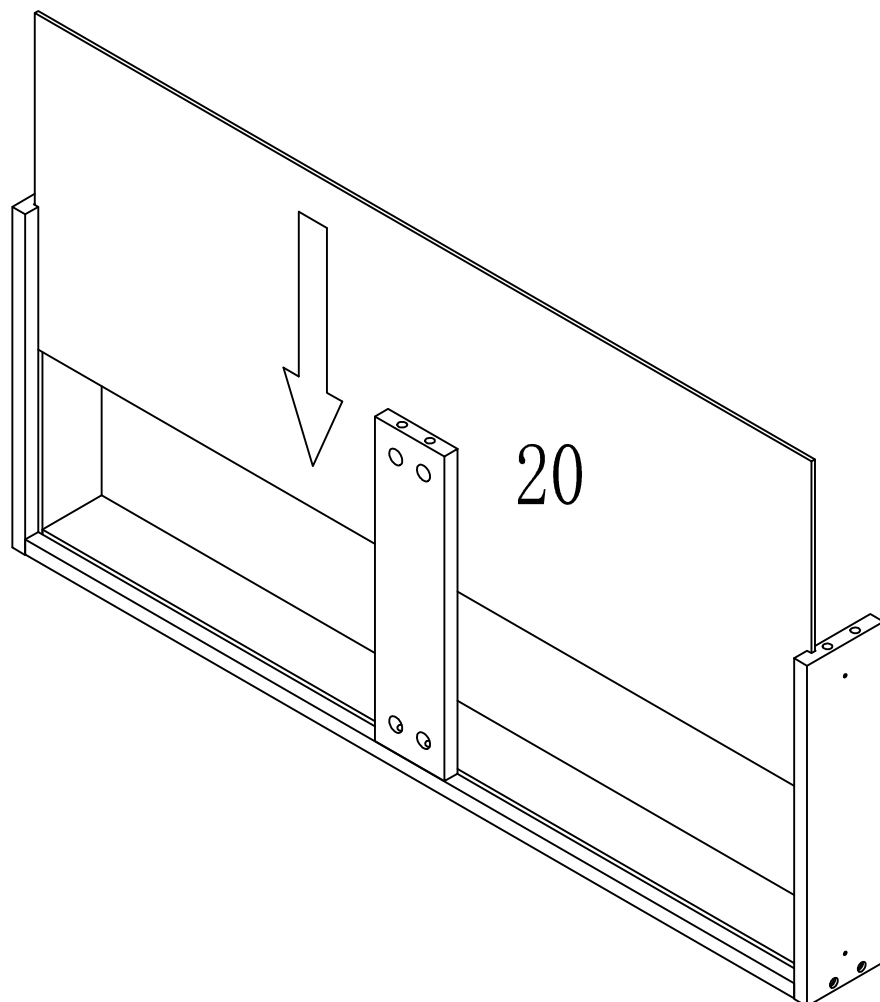

23

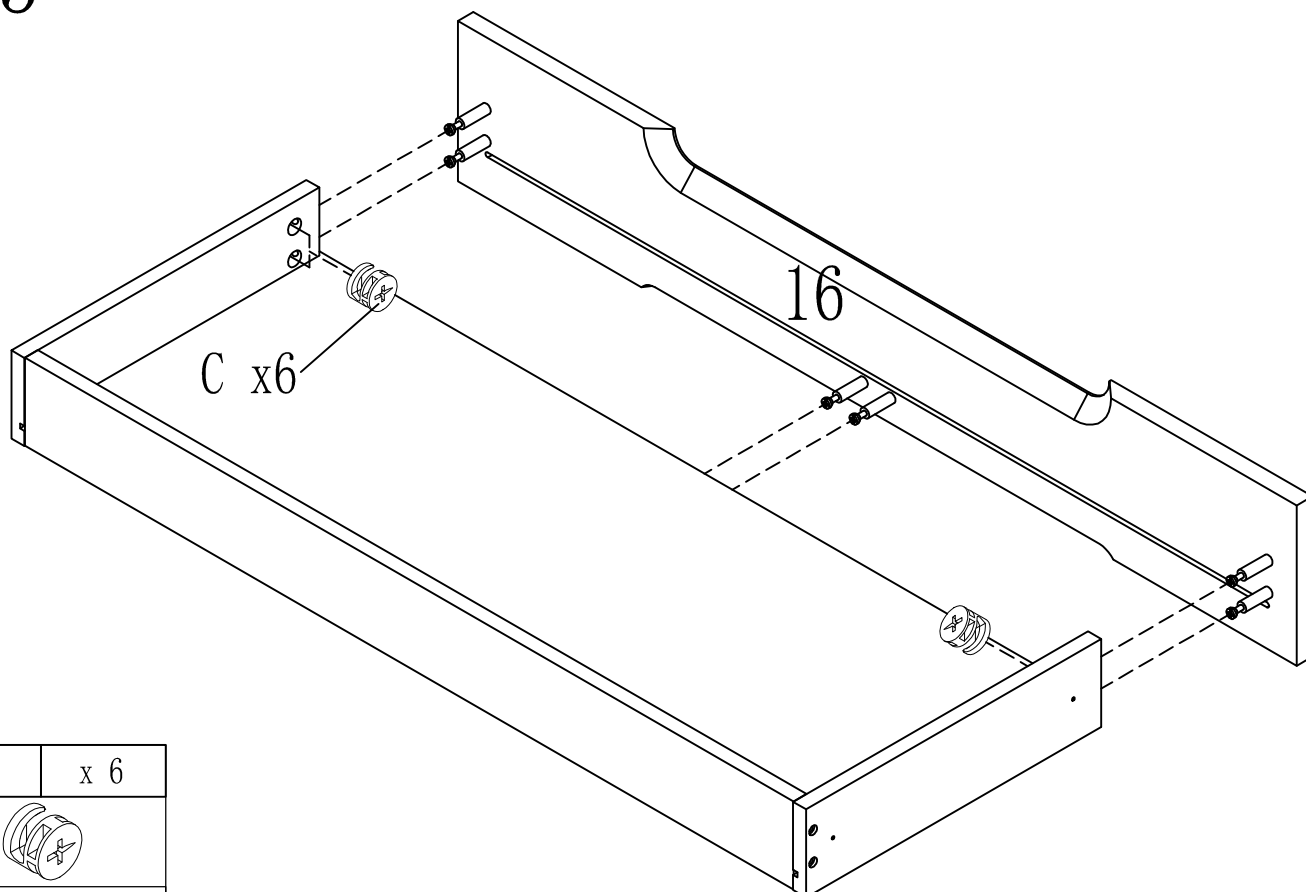

C	x 6
Ø15*12mm	

24

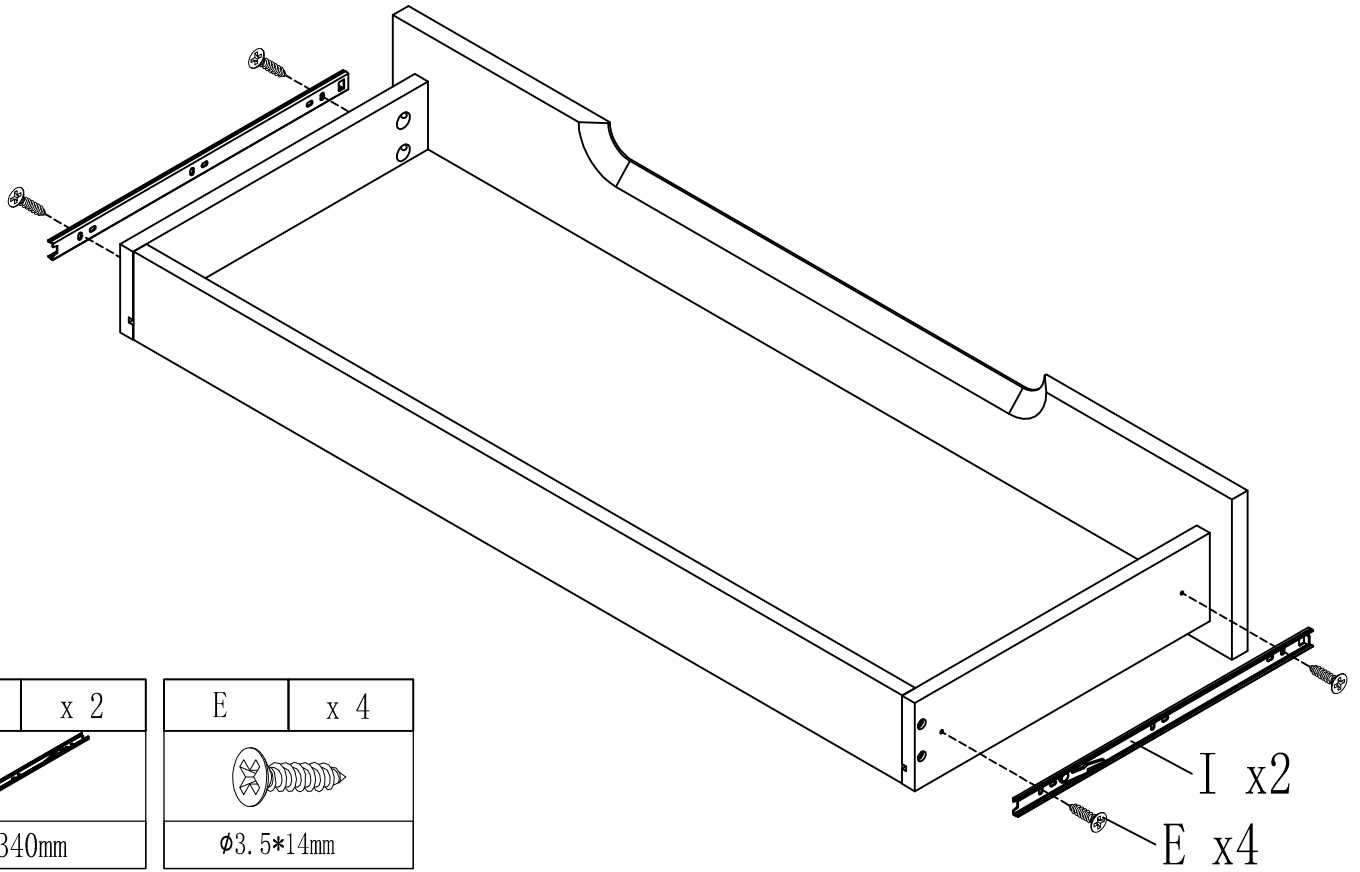

25

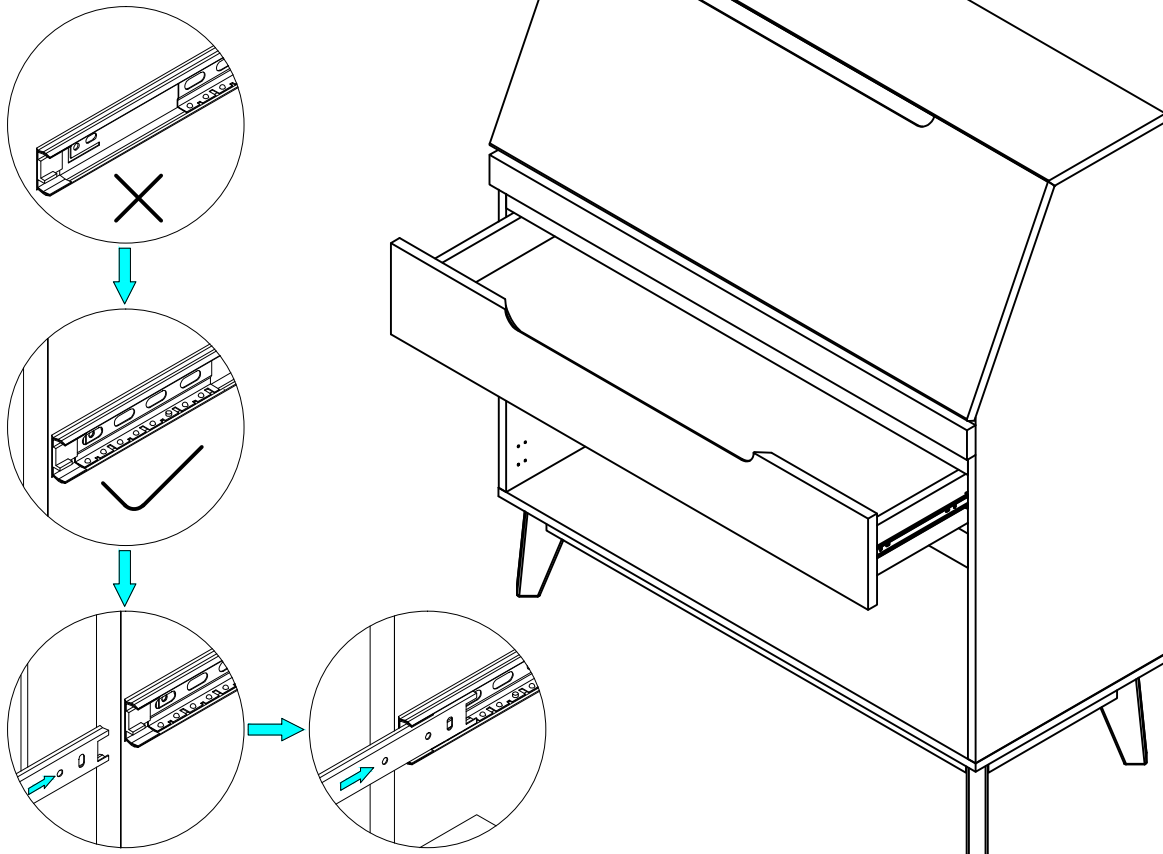

26

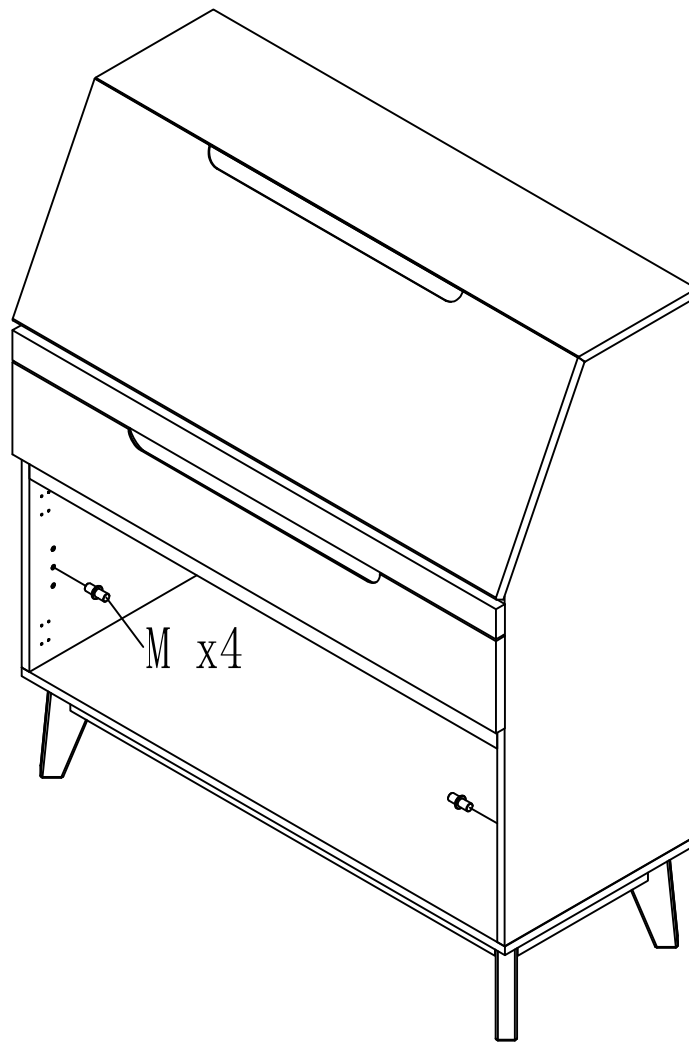

M	x 4
ø5*16mm	

27

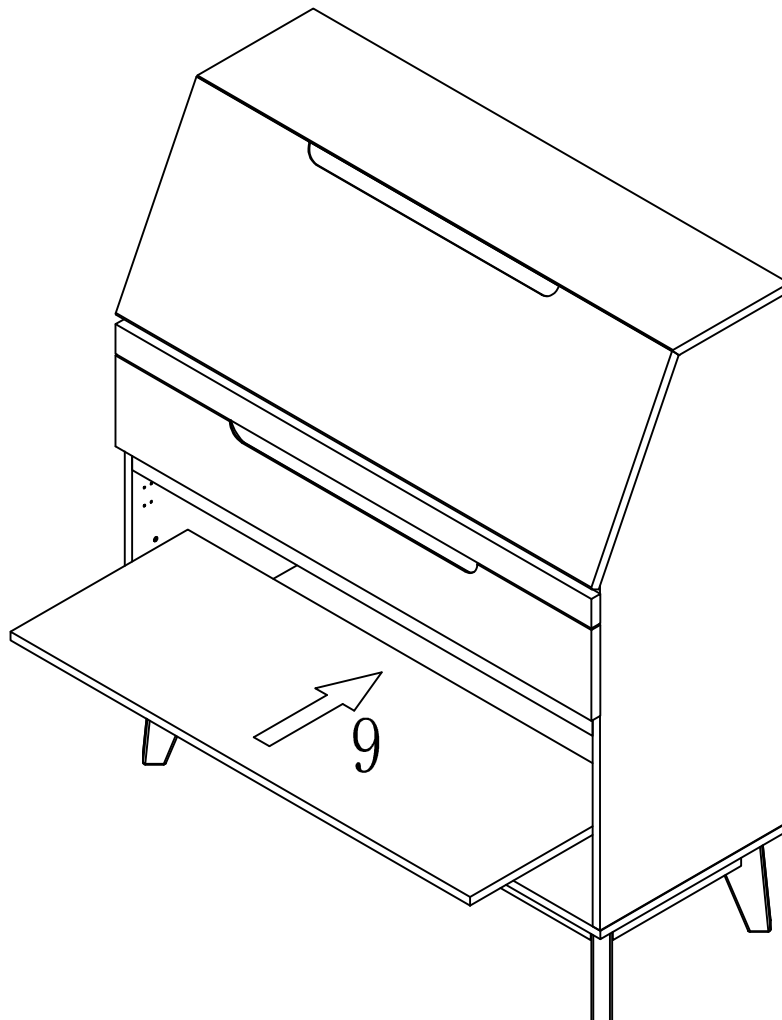

28

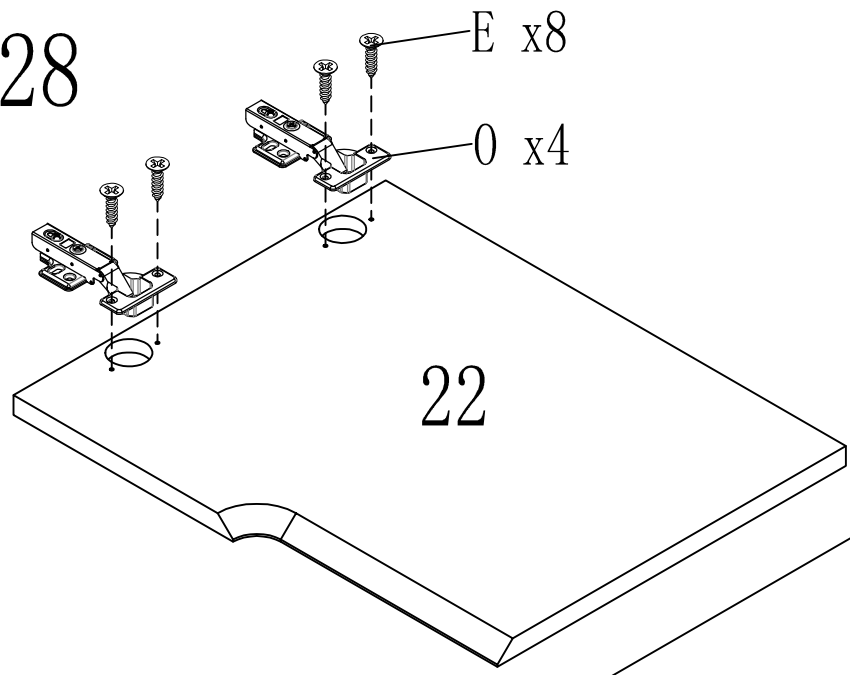

22

23

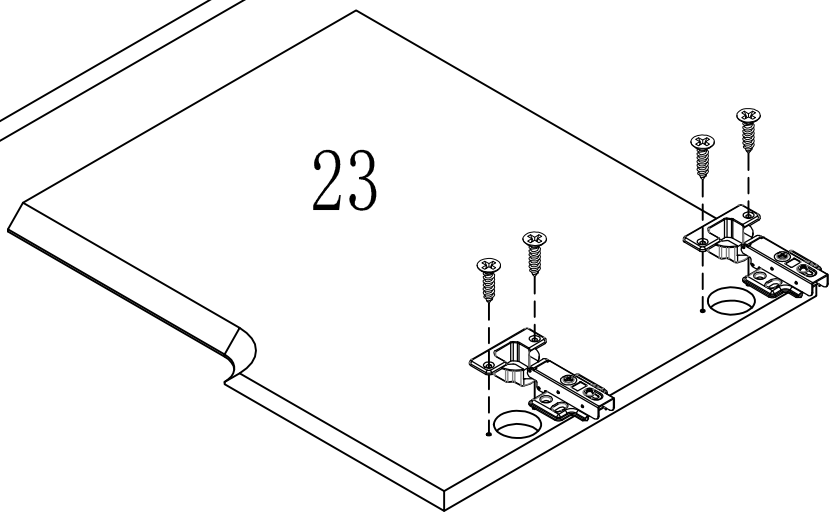

Q	x 4
ø35	

E	x 8
ø3.5*14mm	

29

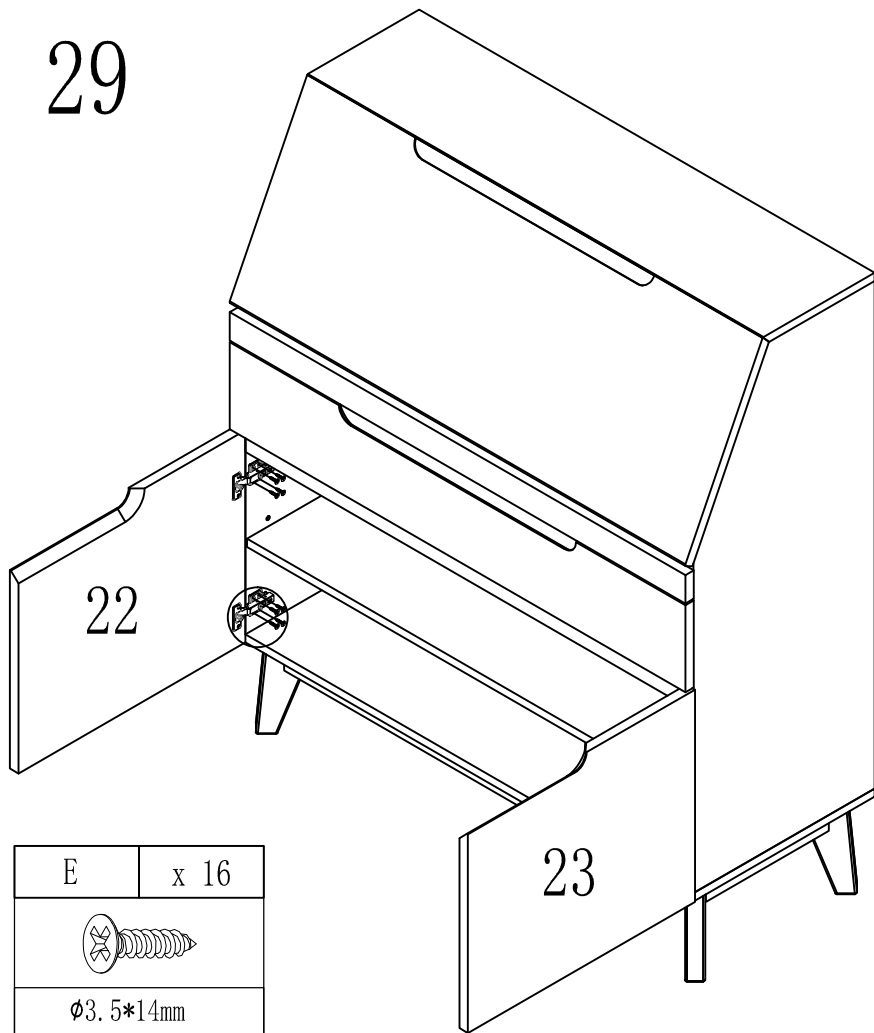

22

23

E	x 16
ø3.5*14mm	

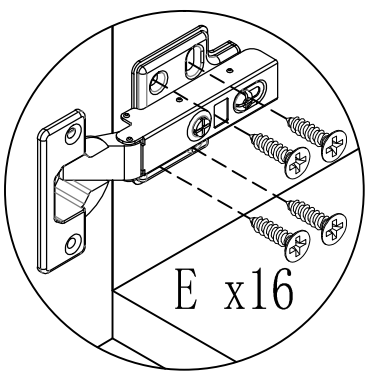

E x16

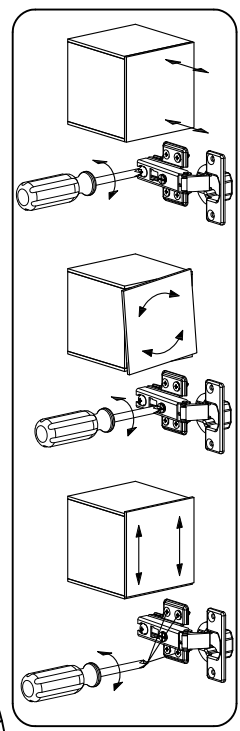

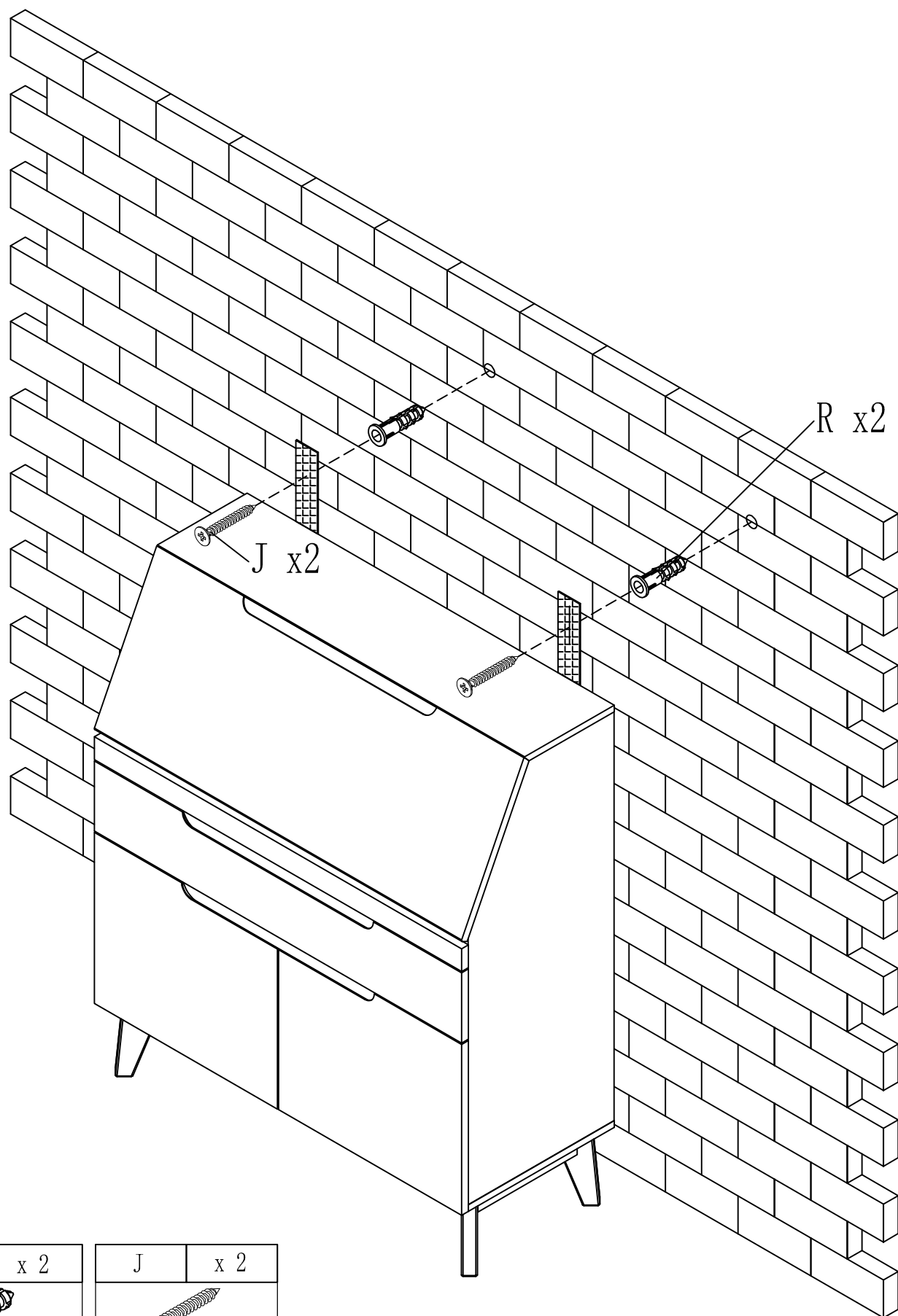

R	x 2
	
M8*40mm	

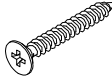
J	x 2
	
M4*35mm	

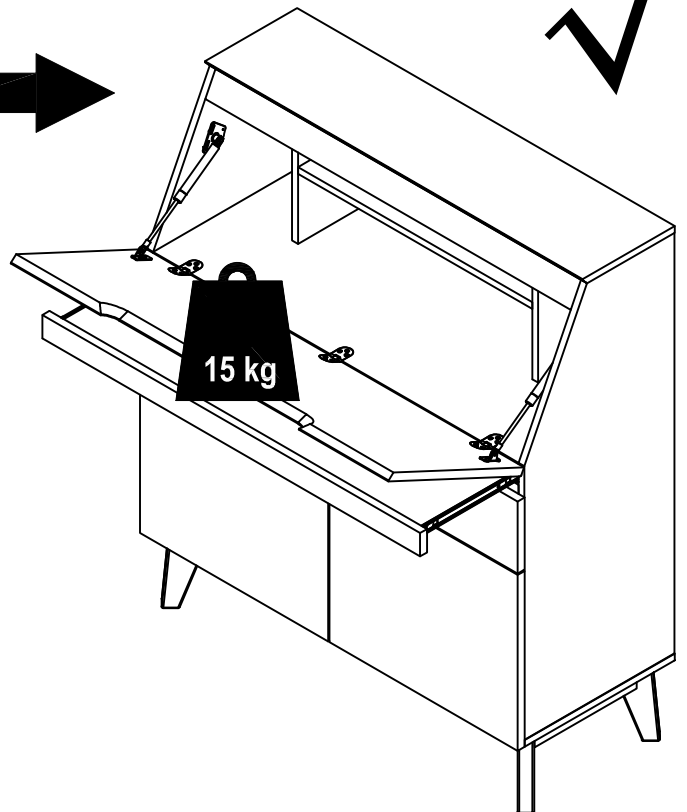
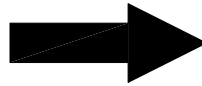
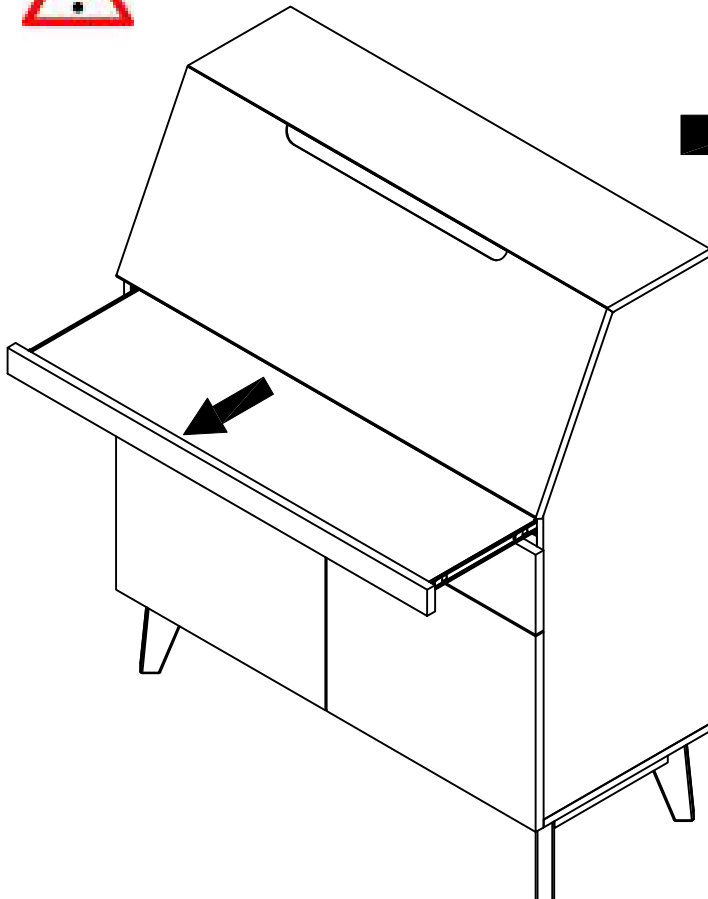
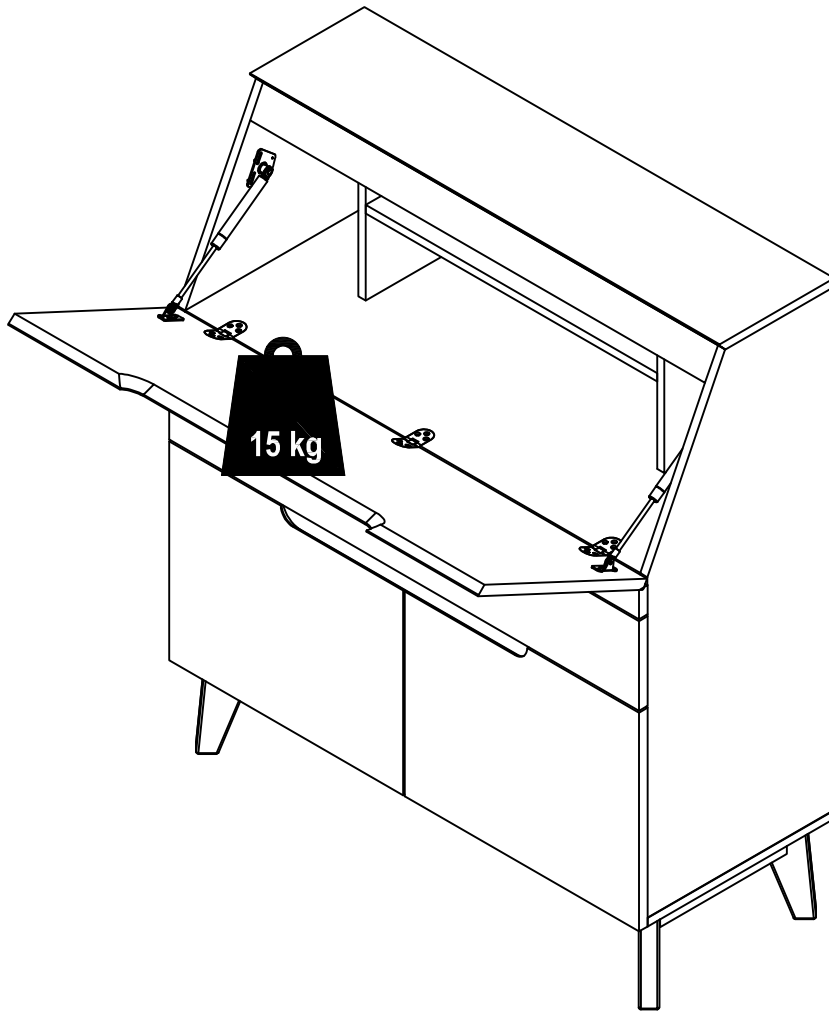

Garantiekarte / guarantee card

Modell: CERVO

48648WE5

#200

Bitte heben Sie die Garantiekarte und den Kaufbeleg auf!

Reklamationen und Ersatzteilbestellungen können nur unter Vorlage der Garantiekarte bearbeitet werden.

Die Garantiezeit beträgt 6 Monaten mit anschließender gesetzlicher Gewährleistung bis 2 Jahre ab Kaufdatum.

Please keep the guarantee card and the receipt of purchase!

Claims and spare part orders can only be processed with this guarantee card.

Guarantee is valid for 6 months and the warranty 2 years since purchasing date.

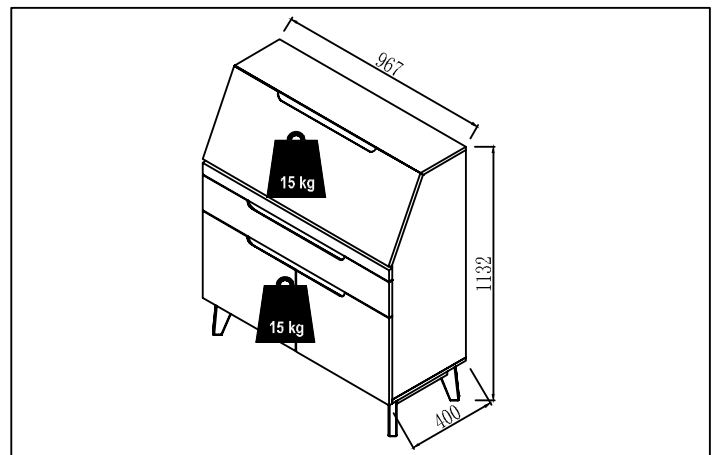
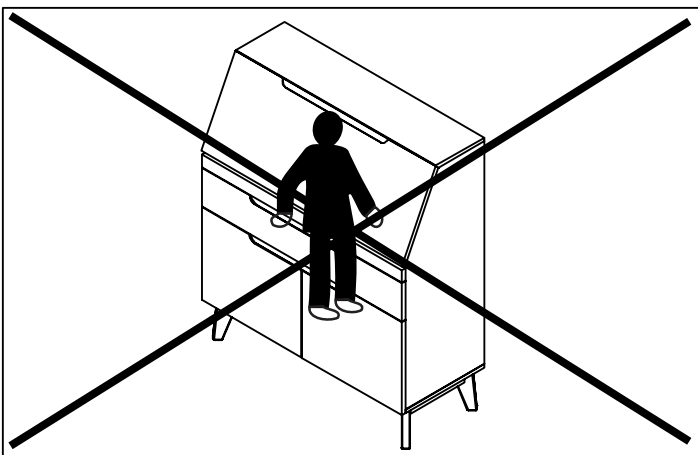
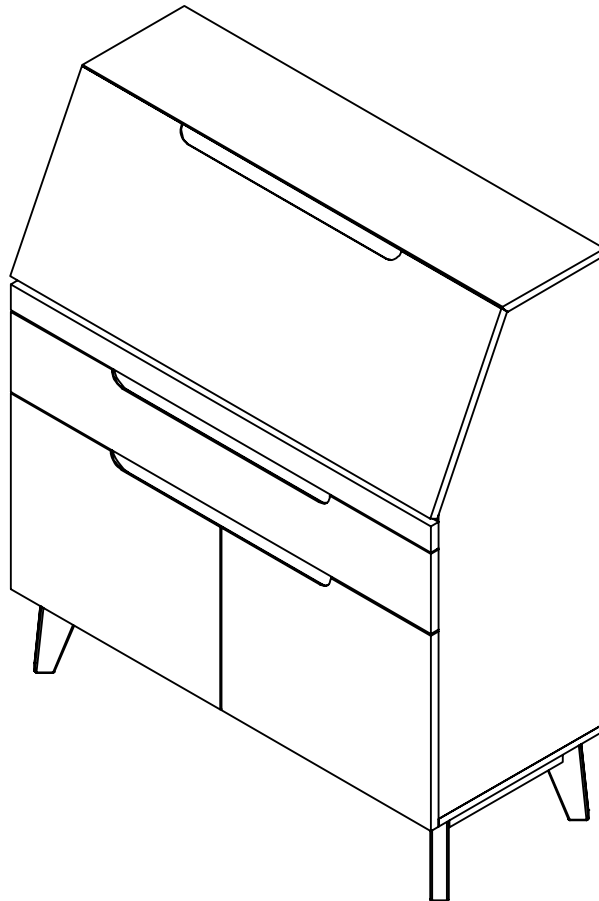

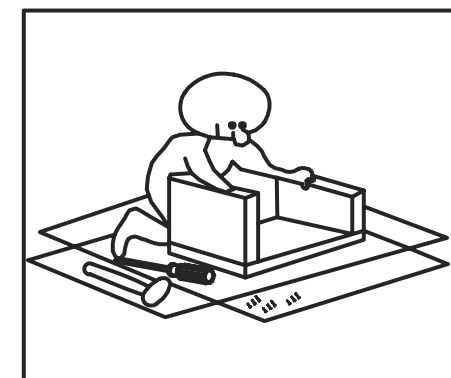
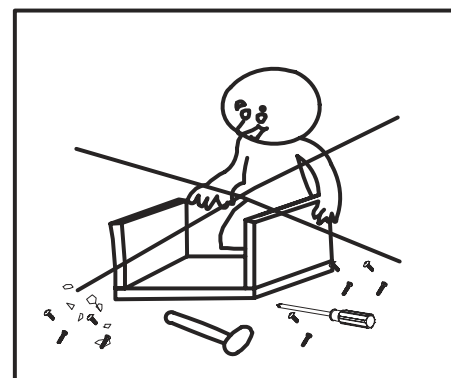
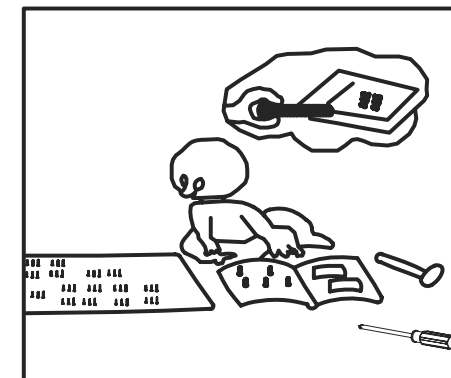
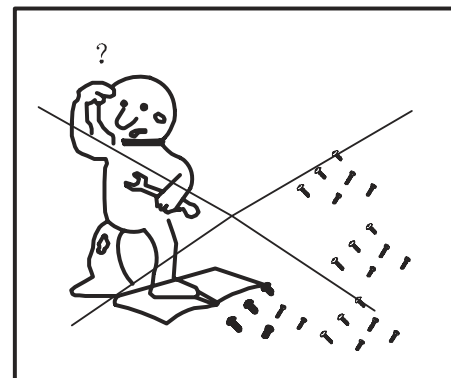
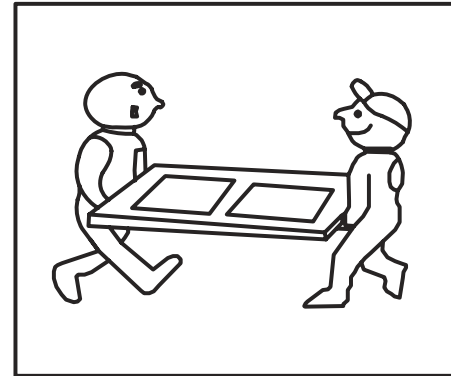
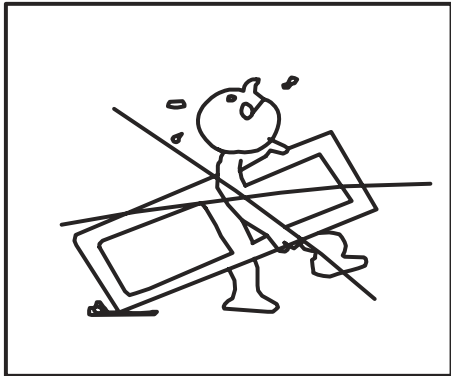
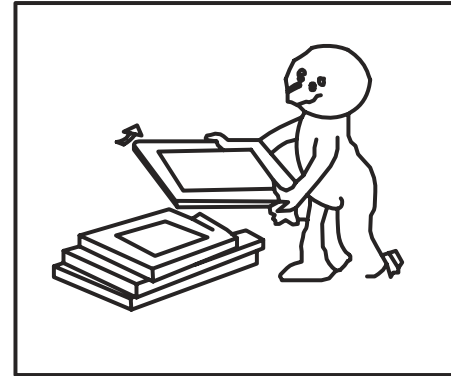
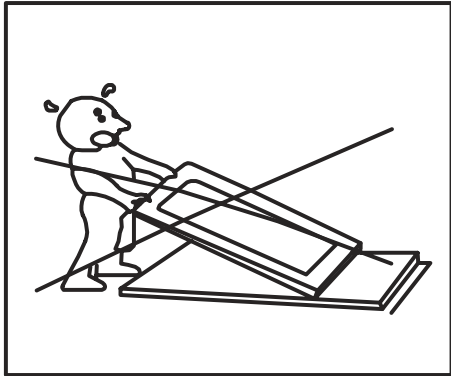
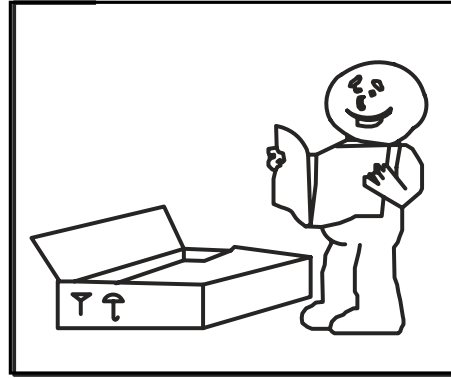
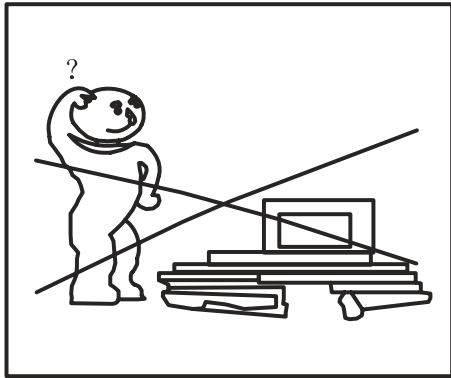



English

Spare parts orders

Should any parts be missing or damaged, please do not forget to indicate the part designation in your order. To ensure quick processing, please send our customer service a copy of the second page on which you mark the part in question with a cross.

Safety instructions

- Packaging material such as plastic bags does not belong in children's hands. Keep the packaging material out of the reach of children.
 - The best way to care for your furniture is to use a soft, lint-free cloth or a leather cloth.
- Wipe the surface with a damp cloth.
- Do not use any microfibre cloths, dirt erasers or aggressive chemical substances.

Deutsch

Ersatzteilbestellung

Sollten Teile fehlen oder beschädigt sein, bitte bei der Bestellung unbedingt die Teilebezeichnung angeben. Für eine schnelle Abwicklung senden Sie bitte eine Kopie der zweiten Seite an unseren Kundendienst, auf der Sie das reklamierte Teil ankreuzen.

Sicherheitshinweise

- Verpackungsmaterial wie z.B. Folienbeutel gehören nicht in Kinderhände. Bewahren Sie das Verpackungsmaterial für Kinder unerreichbar auf.
- Verwenden Sie zur Pflege Ihres Möbels am besten ein weiches, nicht fußelndes Tuch oder ein Ledertuch. Wischen Sie die Oberfläche leicht feucht ab.
- Verwenden Sie keine Microfasertücher, Schmutzradierer und keine scharfen chemischen Substanzen

Svenska

Beställning av reservdelar

Om delar saknas eller är skadade ska alltid beteckningarna av reservdelarna anges vid beställningarna. För att kunna hantera ärendet snabbt, vänligen skicka en kopia av den andra sidan, där

du har kryssat för den reklamerade delen, till vår kundtjänst.

Säkerhetsanvisningar

- Förpackningsmaterial som t.ex. foliepåsar ska hållas bort från barn. Förvara förpackningsmaterialet oåtkomligt för barn.
 - Använd helst en mjuk och luddfri trasa eller en lädertrasa för skötsel av dina möbler.
- Torka av ytan med en lätt fuktig trasa.
- Använd inga mikrofiberdukar, skursvampar eller starka kemiska ämnen.

FRANÇAIS

Commande de pièces de rechange

Si des pièces sont manquantes ou endommagées, veuillez impérativement indiquer la dénomination des pièces lors de la commande. Afin d'assurer un traitement rapide de votre commande, veuillez envoyer une copie de la page 2 à notre service client en cochant la pièce faisant l'objet de la réclamation.

Consignes de sécurité

- Ne pas laisser les matériaux d'emballage comme les sachets en film flexible à la portée des enfants. Veuillez conserver les matériaux d'emballage hors de la portée des enfants.
- Utilisez un chiffon doux non pelucheux ou une peau de chamois pour l'entretien de vos meubles. Essuyez la surface avec un chiffon/une peau de chamois légèrement humide.
- Ne pas utiliser de chiffons en microfibras, de gomme nettoyante ni de produits chimiques agressifs.

Nederlands

Bestellen van vervangingsonderdelen

Indien onderdelen ontbreken of beschadigd zijn, gelieve bij de bestelling absoluut de naam van de onderdelen op te geven. Gelieve voor een snelle afhandeling een kopie van de tweede bladzijde naar onze klantendienst te sturen, waarop u het onderdeel aankruist waarmee een probleem is.

Veiligheidsinstructies

- Verpakkingsmateriaal, zoals bv. foliezakjes, hoort niet in kinderhanden.

Bewaar het verpakkingsmateriaal buiten bereik van kinderen.

- Gebruik voor het onderhoud van uw meubelstuk bij voorkeur een zachte, pluisvrije doek of een zeemleer. Wrijf het oppervlak lichtelijk vochtig af.
- Gebruik geen microvezeldoeken, speciale reinigingssponzen of scherpe chemische substanties.

ESPAÑOL

Pedido de piezas de repuesto

En el caso de que alguna pieza presente fallos o esté dañada, es imprescindible indicar en el pedido la denominación de la misma. Para que la tramitación del pedido sea rápida, envíe por favor una copia de la segunda página donde ha marcado la pieza a reclamar a nuestro servicio de atención al cliente.

Instrucciones de seguridad

- Los materiales de embalaje como p.ej. las bolsas de plástico no son juguetes. Mantenga los materiales de embalaje fuera del alcance de los niños.
 - Utilice preferentemente para el cuidado de sus muebles un paño suave y que no deje pelusas o un paño de cuero.
- Limpie la superficie con el paño ligeramente humedecido.
- No utilice paños de microfibra, quitamanchas o sustancias químicas abrasivas.



Dansk

Reservedelsbestilling

Såfremt dele mangler eller er beskadigede, bedes De angive delbetegnelsen ved bestillingen. For en hurtig behandling bedes De sende en kopi af side 2 til vores kundeservice, hvorpå De har afkrydset den reklamerede del.

Sikkerhedshenvisninger

- Emballagemateriale som f.eks. folieposer må ikke komme i hænderne på børn. Emballagemateriale bør opbevares utilgængeligt for børn.
- Til pleje af møblet bør De helst anvende en blød, ikke-fnuggende klud eller et vaskeskind.

Overfladen tørres let fugtigt af.

- Anvend ikke mikrofiberklude, snavsfjerner eller stærke, kemiske stoffer.

Hrvatski

Naručivanje rezervnih dijelova

Ako dijelovi nedostaju ili su oštećeni, kod naručivanja obavezno navedite oznaku dijela. Za brzu obradu pošaljite kopiju druge stranice našoj Službi za korisnike na kojoj je križićem označen reklamirani dio.

Sigurnosne upute

- Ambalažni materijal (vrećica od folije) mora se držati podalje od djece. Stoga ga držite izvan dohvata djece.
- Za čišćenje namještaja upotrijebite mekanu krpicu koja ne ostavlja dlačice ili kožnatu krpicu.

Obrišite površinu malo navlaženom krpom.

- Nemojte koristiti krpe s mikrovlaknima, uklanjače prljavštine ni druge kemijski agresivne tvari.

Italiano

Ordine di pezzi di ricambio

Qualora manchino, o siano danneggiati, dei pezzi, specificare il nome del pezzo all'ordine. Per un rapido svolgimento, si prega di inviare una copia della seconda pagina al nostro Servizio Clienti, barrando il pezzo in questione.

Avvertenze di sicurezza

- Tenere il materiale di imballaggio, quale per esempio sacchetti di plastica, fuori dalla portata dei bambini. Conservare il materiale di imballaggio fuori dalla portata dei bambini.

- Per pulire il mobile, utilizzare un panno che non lascia pelucchi o un panno in pelle.

Asciugare la superficie con un panno leggermente inumidito.

⚠ Non usare panni in microfibra, gomme per lo sporco, o sostanze chimiche aggressive.

Polski

Zamówienie na części zamienne

W przypadku braku części lub ich uszkodzeń w zamówieniu proszę koniecznie podać oznaczenie części. W celu szybkiej realizacji reklamacji proszę przesłać do działu obsługi klienta kopię drugiej strony z zakreśloną reklamowaną częścią.

Wskazówki dotyczące bezpieczeństwa

- Materiałów opakowaniowych, np. worków foliowych, nie wolno dawać dzieciom. Materiały opakowaniowe należy trzymać w miejscu niedostępnym dla dzieci.
- Do pielęgnacji mebla najlepiej używać miękkiej, niepylącej ściereczki lub irchy.

Wycierać powierzchnię lekko zwilżoną ściereczką.

- Nie stosować ściereczek z mikrofibry, gąbek do czyszczenia brudu ani silnie działających substancji chemicznych.

Slovensky

Objednávanie náhradných dielov

Ak by diely chýbali alebo boli poškodené, pri objednávaní bezpodmienečne uvedte označenie dielu. Pre rýchlejšie vybavenie pošlite kópiu druhej strany nášmu zákazníkemu servisu, na ktorej reklamovaný diel označíte križikom.

Bezpečnostné pokyny

- Obalový materiál, ako napr. fóliové vrečky, nepatrí do rúk deťom. Obalový materiál uschovajte mimo dosahu detí.
- Na ošetrovanie nábytku použite najlepšie mäkkú handru, ktorá nepúšťa vlákna, alebo koženú utierku. Povrch utrite jemne navlhčenou handrou.

- Nepoužívajte utierky z mikrovlákná, čistiace gumy a agresívne chemické látky.

SLOVENŠČINA

Naročilo nadomestnih delov

Če deli manjkajo ali so poškodovani, ob naročilu nujno navedite tudi opis dela. Za hitro obdelavo zahtevka naši službi za stranke pošljite kopijo druge strani, na kateri označite reklamirani del.

Varnostni napotki

- Embalažni material, kot so plastične vrečke, ne spadajo v roke otrok. Embalažni material shranjujte zunaj dosega otrok.
- Za nego svojega pohištva uporabite mehko krpo, ki se ne kosmati, ali usnjeno krpo. Površine obrišite z rahlo navlaženo krpo.
- Ne uporabljajte krp iz mikrovlaknen, čistilnih radirk in močnih kemičnih sredstev.

Garantiekarte / guarantee card

Modell: CERVO

48648WE5

Bitte bei Ersatzteilbestellungen die fehlenden oder beschädigten Teile kennzeichnen.
Please mark the missing or damaged parts if you place a spare part order.

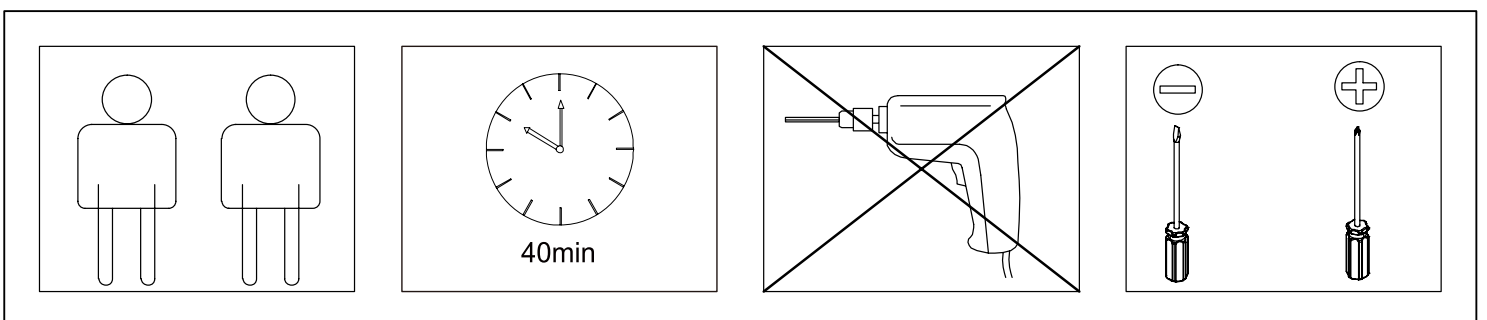
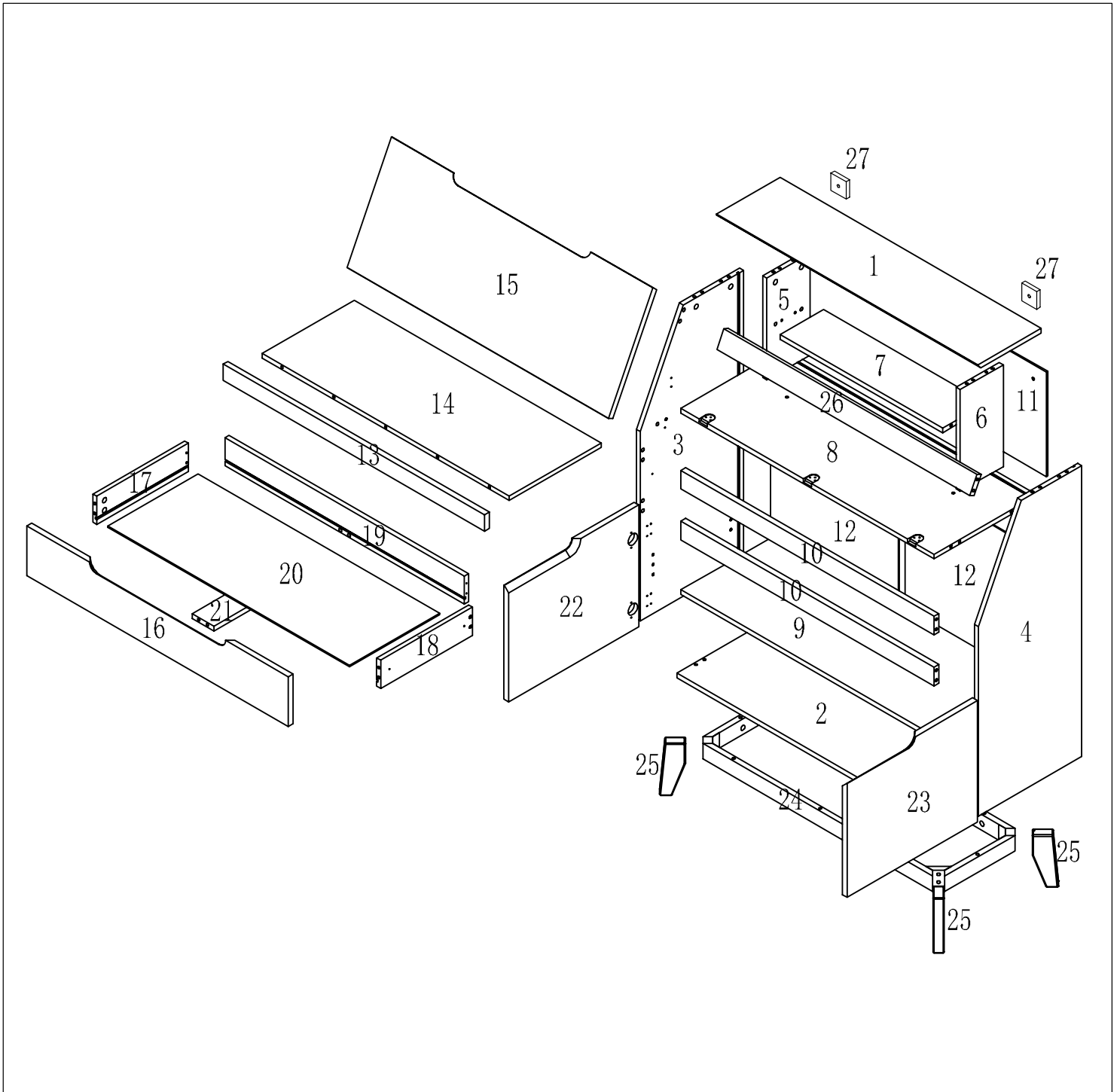

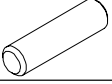
A	x 26
	
Ø7.8*30mm	

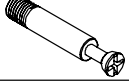
B	x 47
	
M6*36mm	

C	x 47
	
Ø15*12mm	

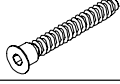
D	x 8
	
M7*50mm	

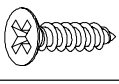
E	x 81
	
Ø3.5*14mm	

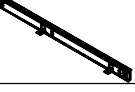
F	x 1
	
L355mm	

G	x 1
	
L355mm	

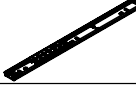
H	x 2
	
L340mm	

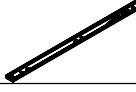
I	x 2
	
L340mm	

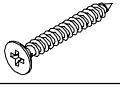
J	x 6
	
M4*35mm	

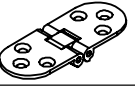
K	x 3
	
79*30*8mm	

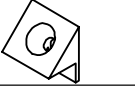
L	x 10
	
14*14*9mm	

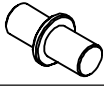
M	x 4
	
Ø5*16mm	

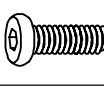
N	x 8
	
M6*35mm	

O	x 8
	
Ø16*Ø6.5*T1mm	

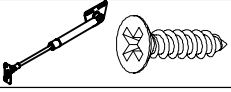
P1	x2	P2	x4
			

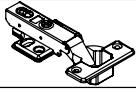
Q	x 4
	
Ø35	

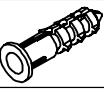
R	x 2
	
M8*40mm	

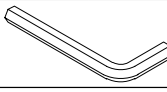
S	x 1
	
M4	

U	x 1
	
25*25*15mm	

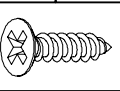
V	x 2
	
Ø3.5*16mm	

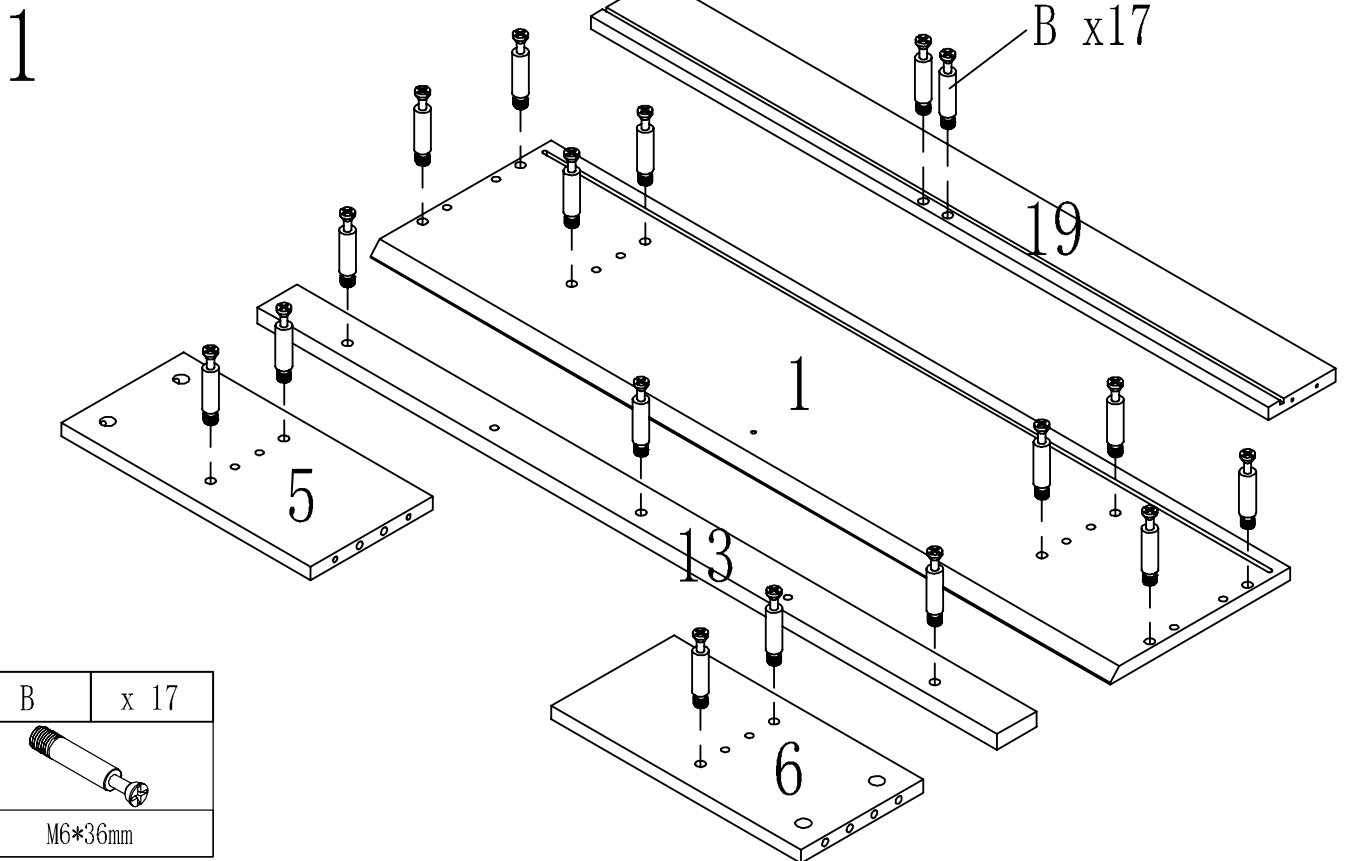

2

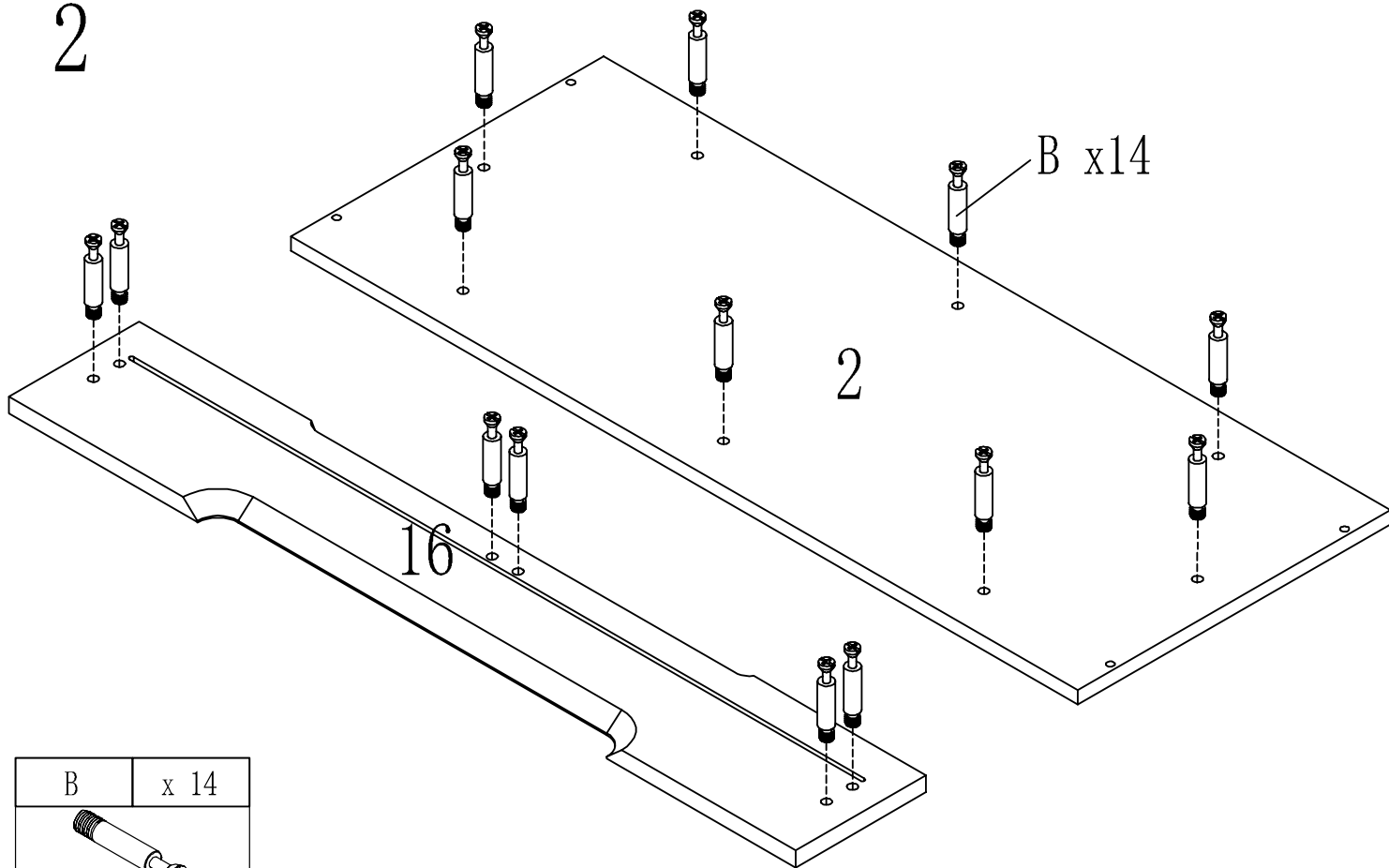

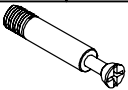

B	x 14
	
M6*36mm	

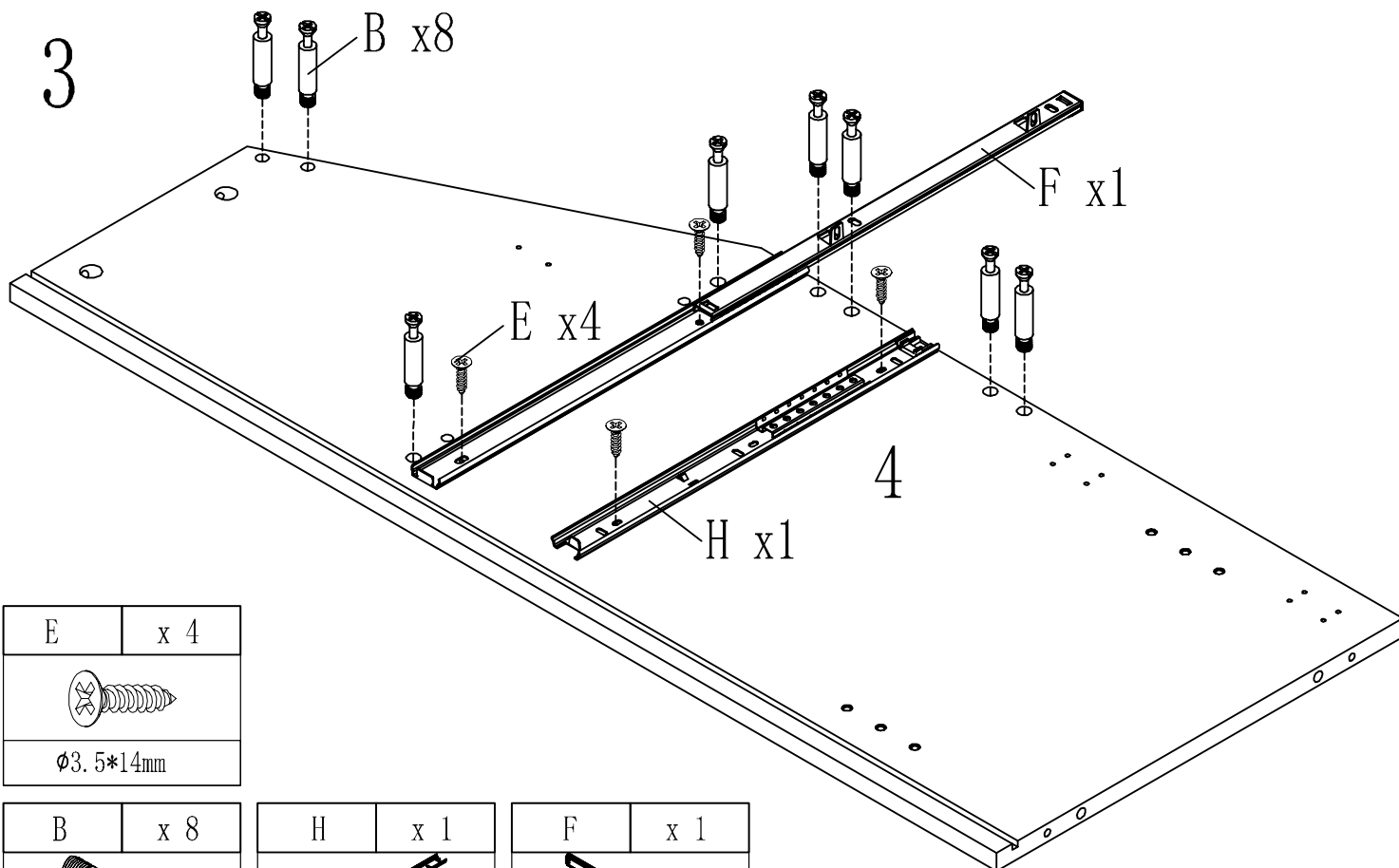
3

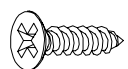

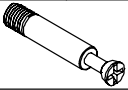
E	x 4
	
Ø3.5*14mm	

B	x 8
	
M6*36mm	

H	x 1
	
L340mm	

F	x 1
	
L355mm	

4

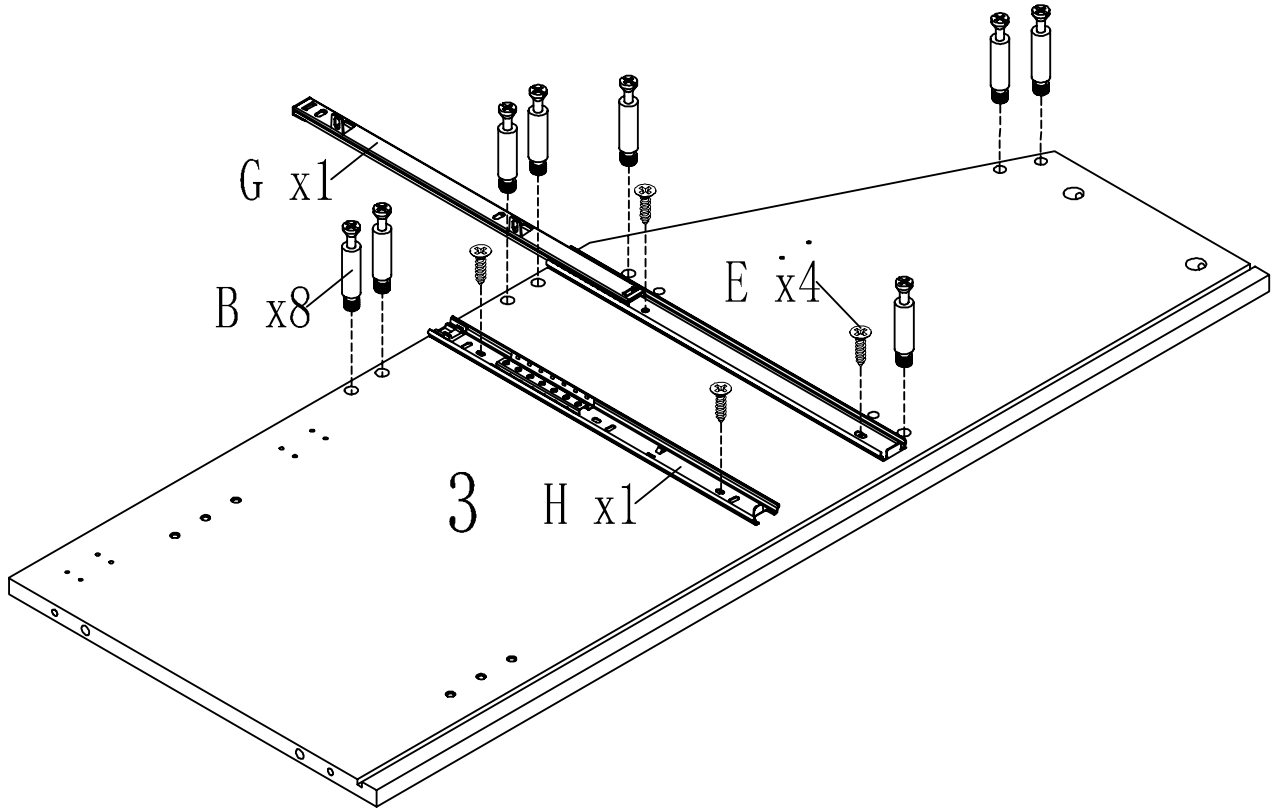

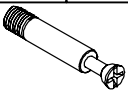
B	x 8
	
M6*36mm	

H	x 1
	
L340mm	

G	x 1
	
L355mm	

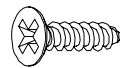
E	x 4
	
φ3.5*14mm	

5

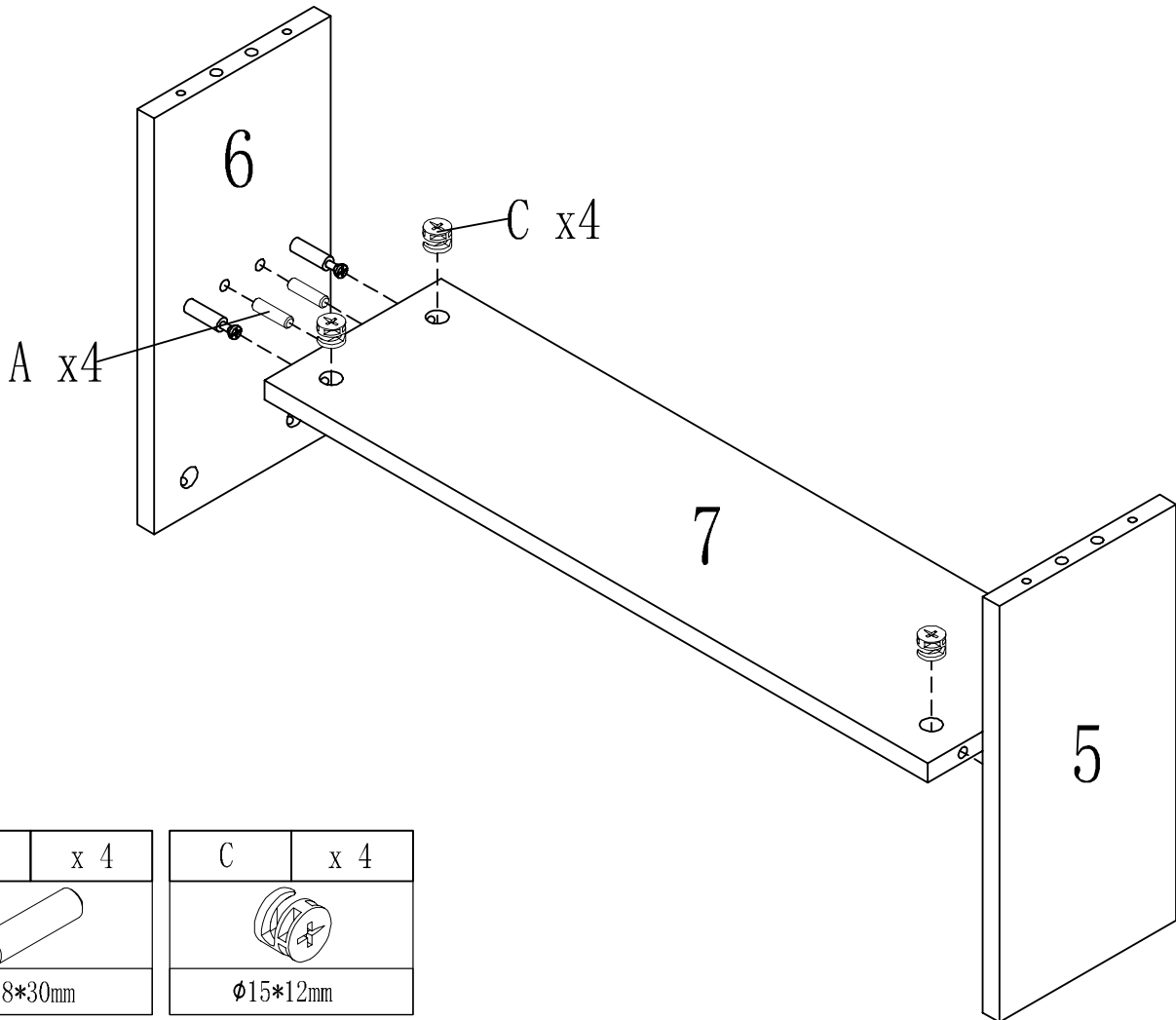

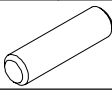

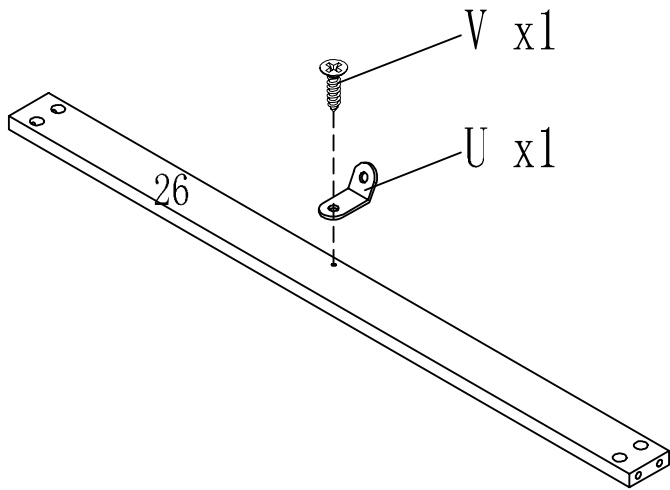

A	x 4
	
φ7.8*30mm	

C	x 4
	
φ15*12mm	

6

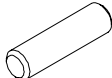

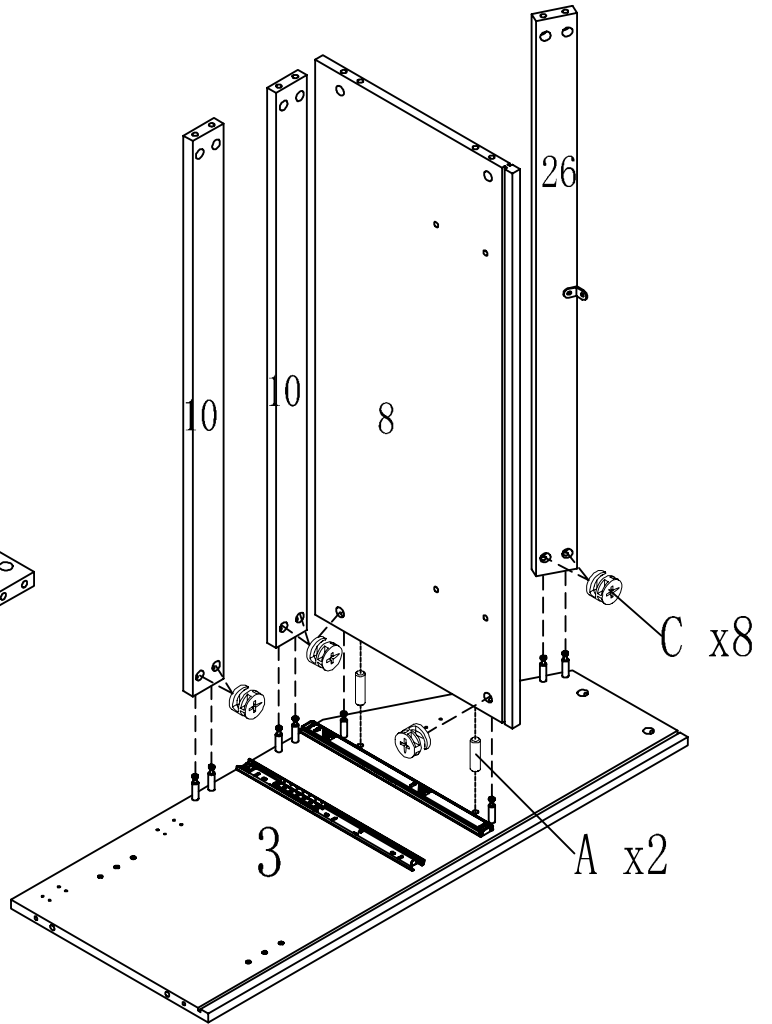

U	x 1	V	x 1
			
25*25*15mm		φ3.5*16mm	
A	x 2	C	x 8
			
φ7.8*30mm		φ15*12mm	



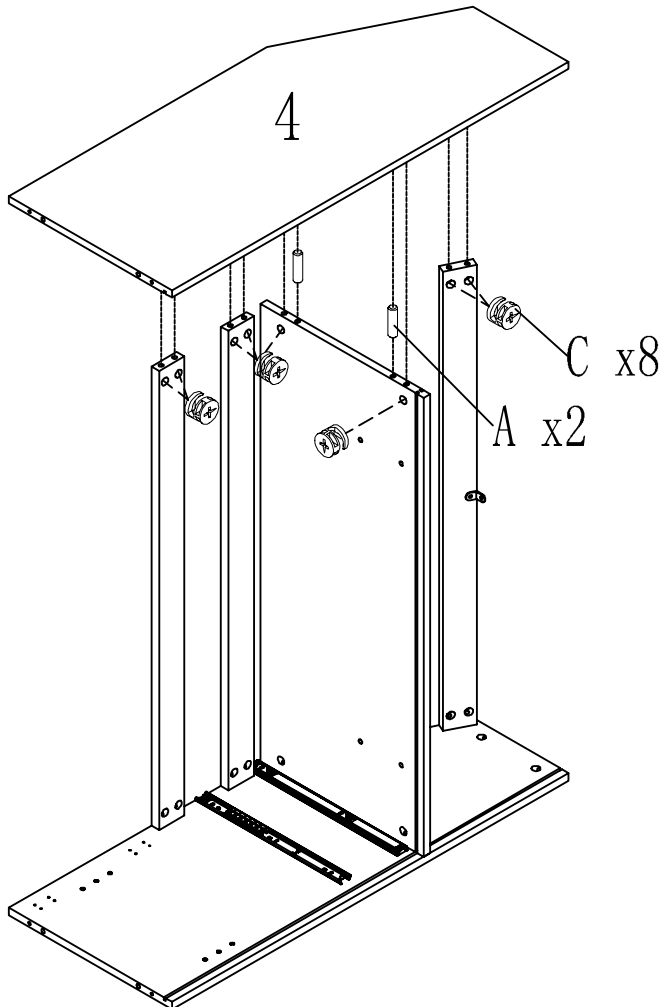

7

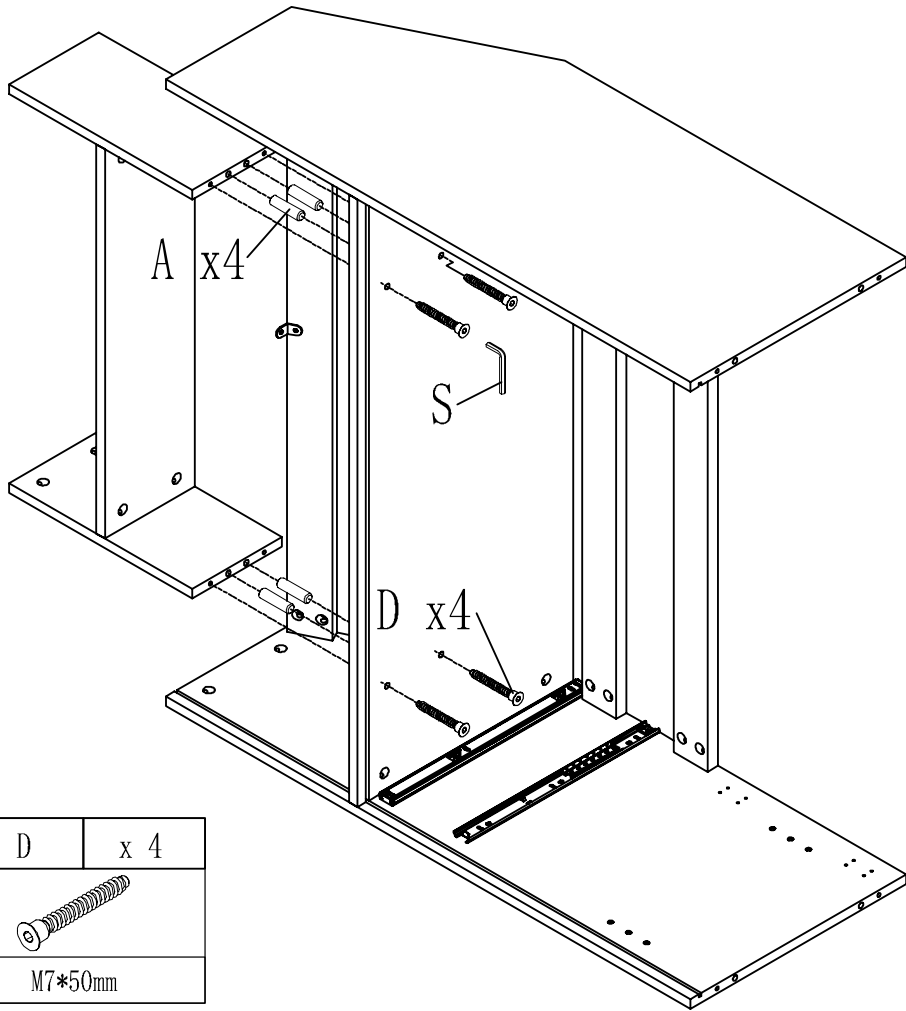

A	x 2	C	x 8
			
φ7.8*30mm		φ15*12mm	

8

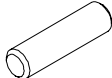

S	x 1
	
M4	

A	x 4
	
φ7.8*30mm	

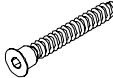
D	x 4
	
M7*50mm	

9

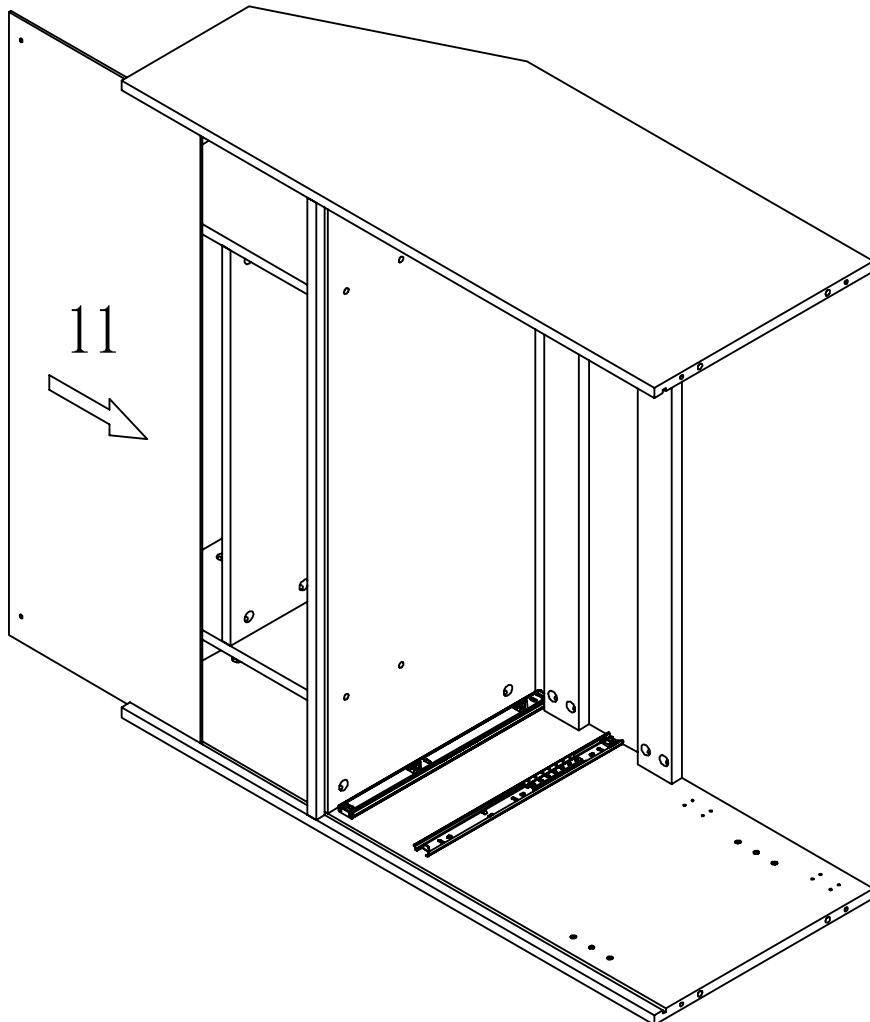

10

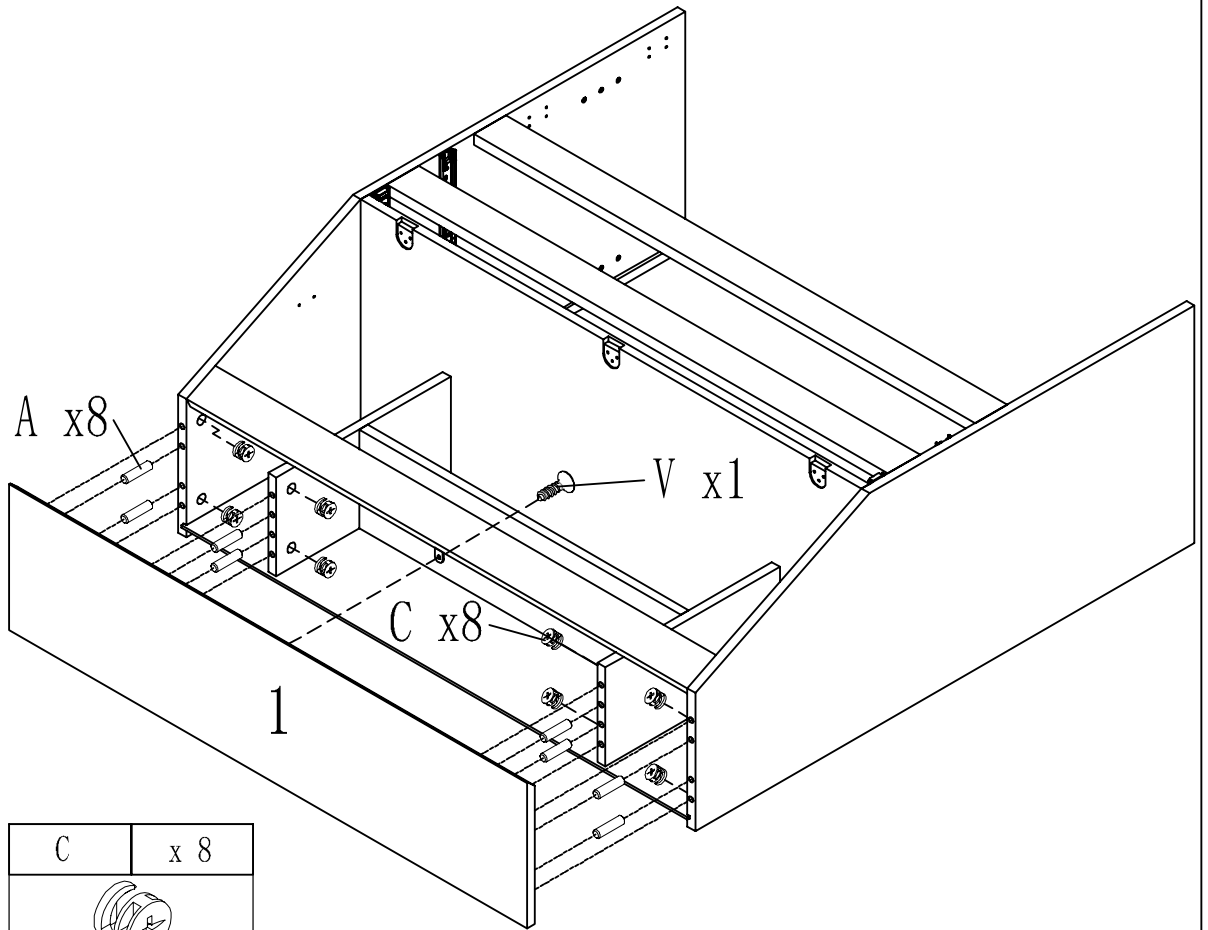

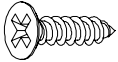
V	x 1
	
Ø3.5*16mm	

A	x 8
	
Ø7.8*30mm	

C	x 8
	
Ø15*12mm	

11

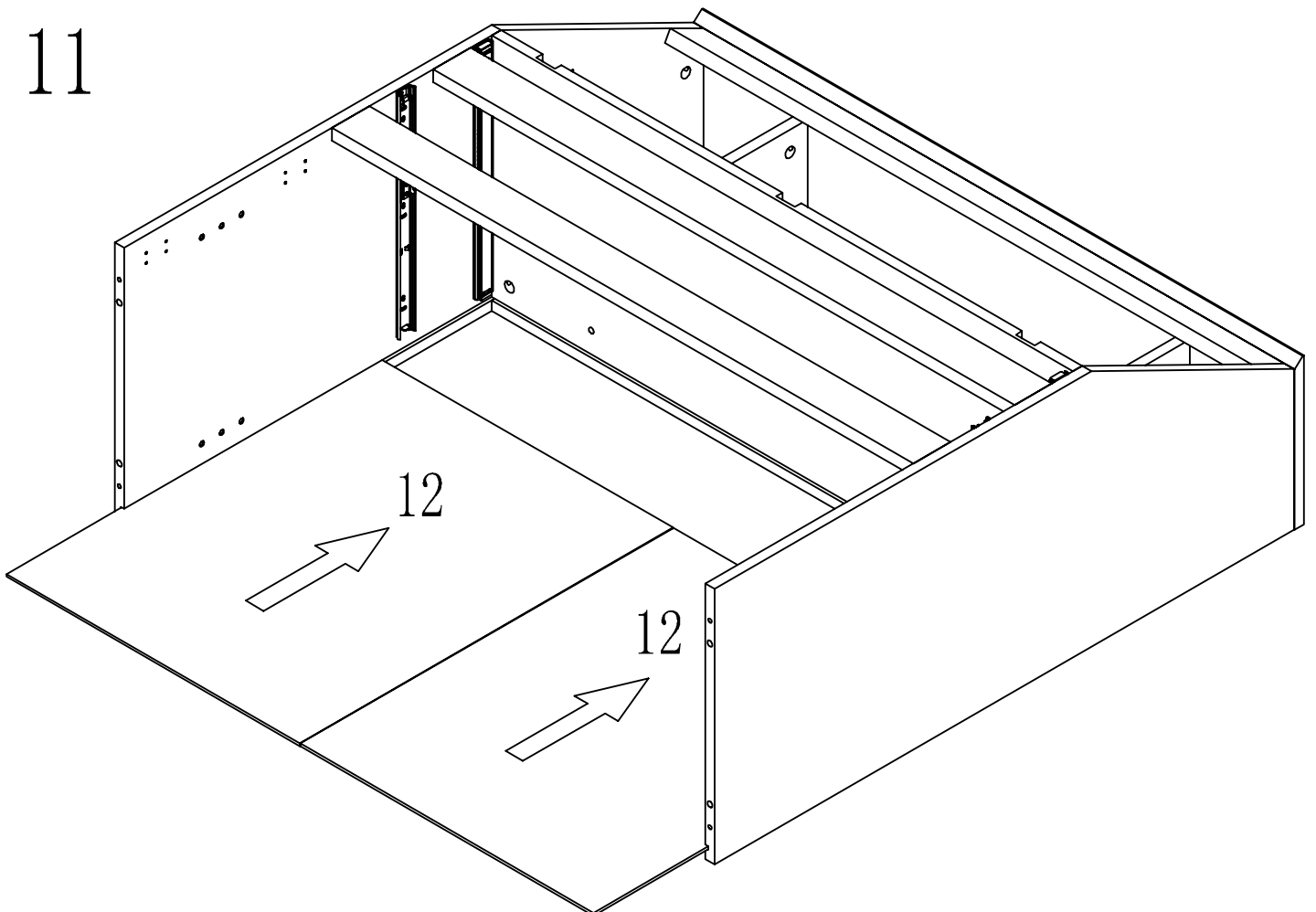

12

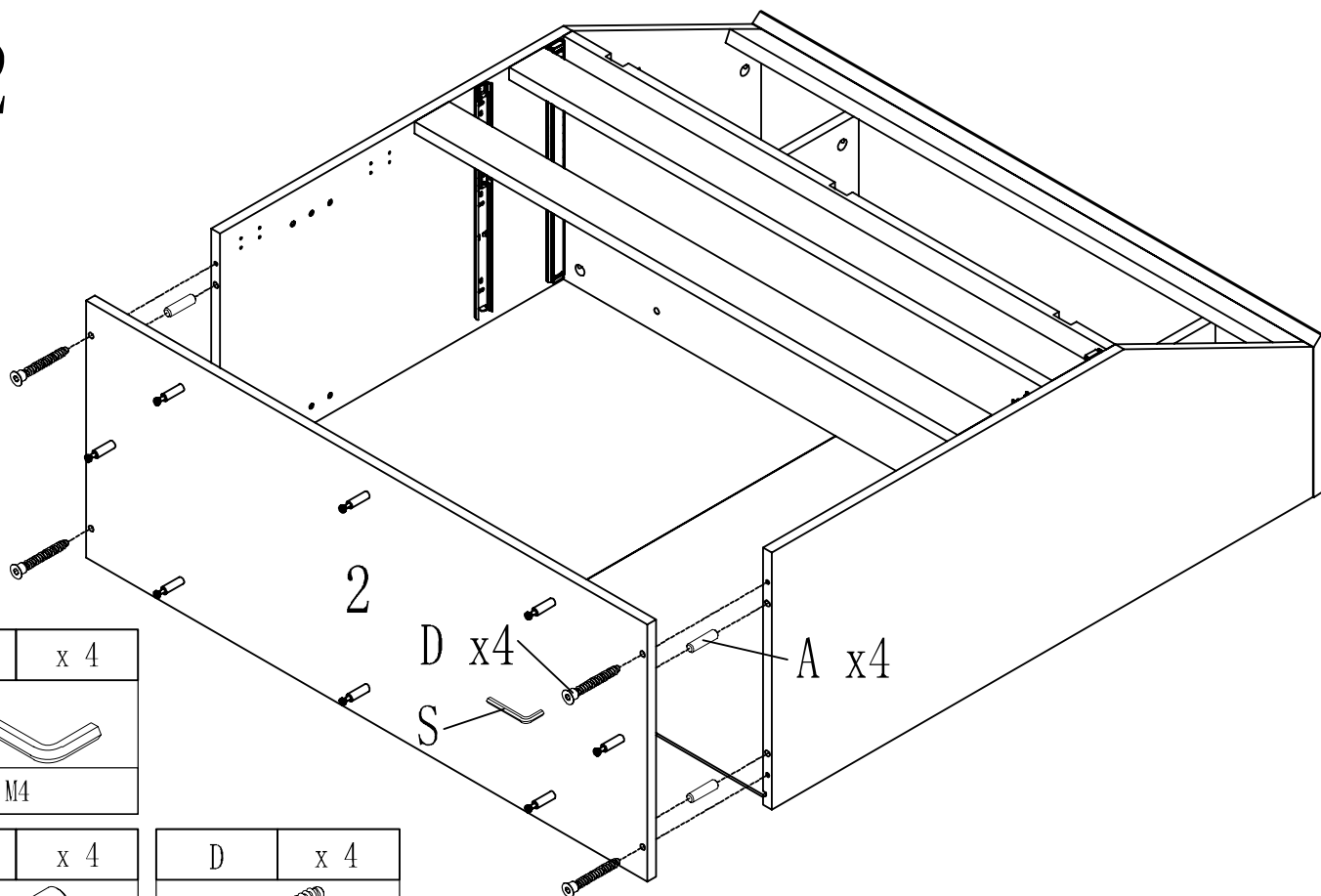

S	x 4
M4	

A	x 4
φ7.8*30mm	

D	x 4
M7*50mm	

13

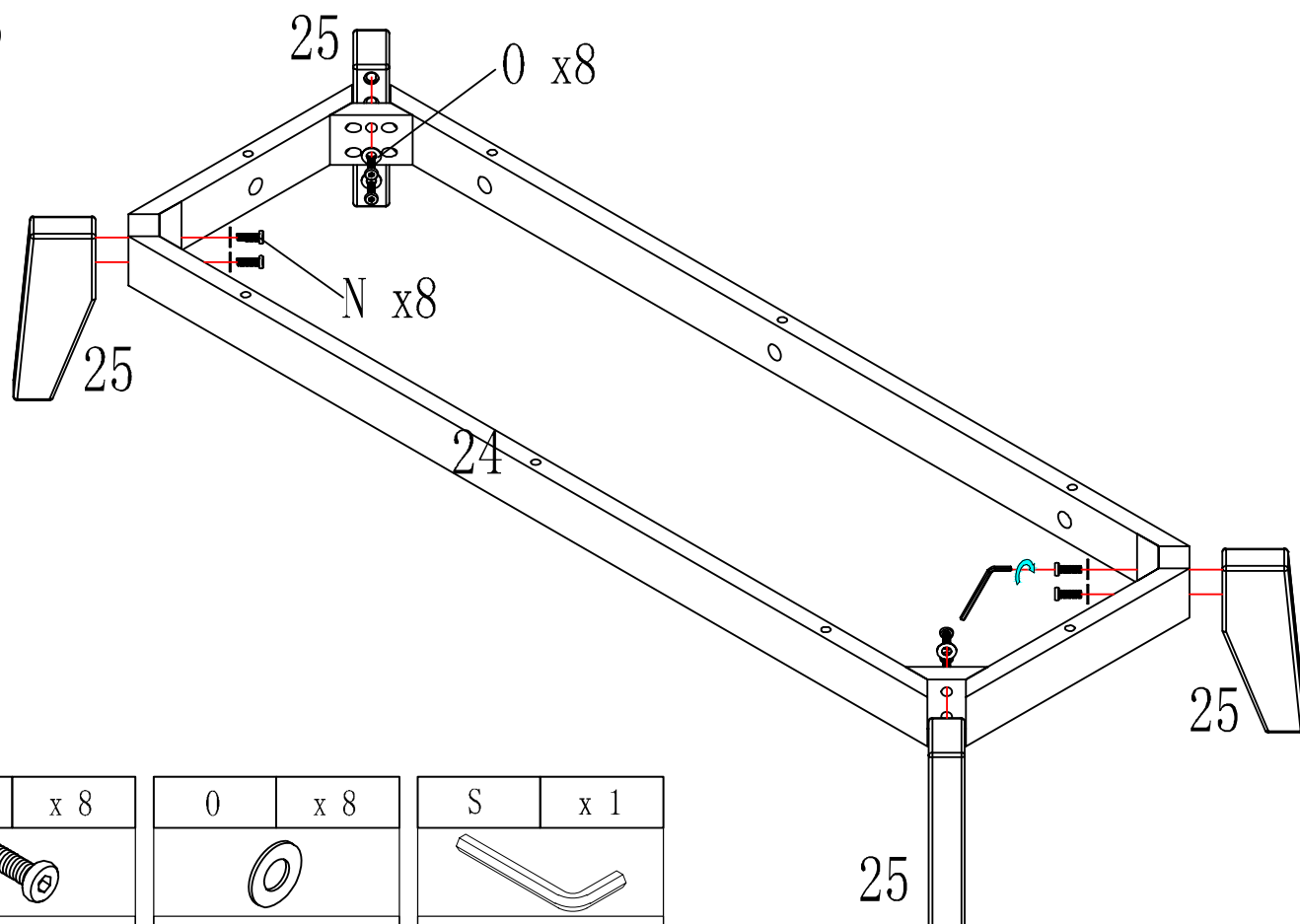



N	x 8
M6*35mm	

0	x 8
φ16*φ6.5*T1mm	

S	x 1
M4	

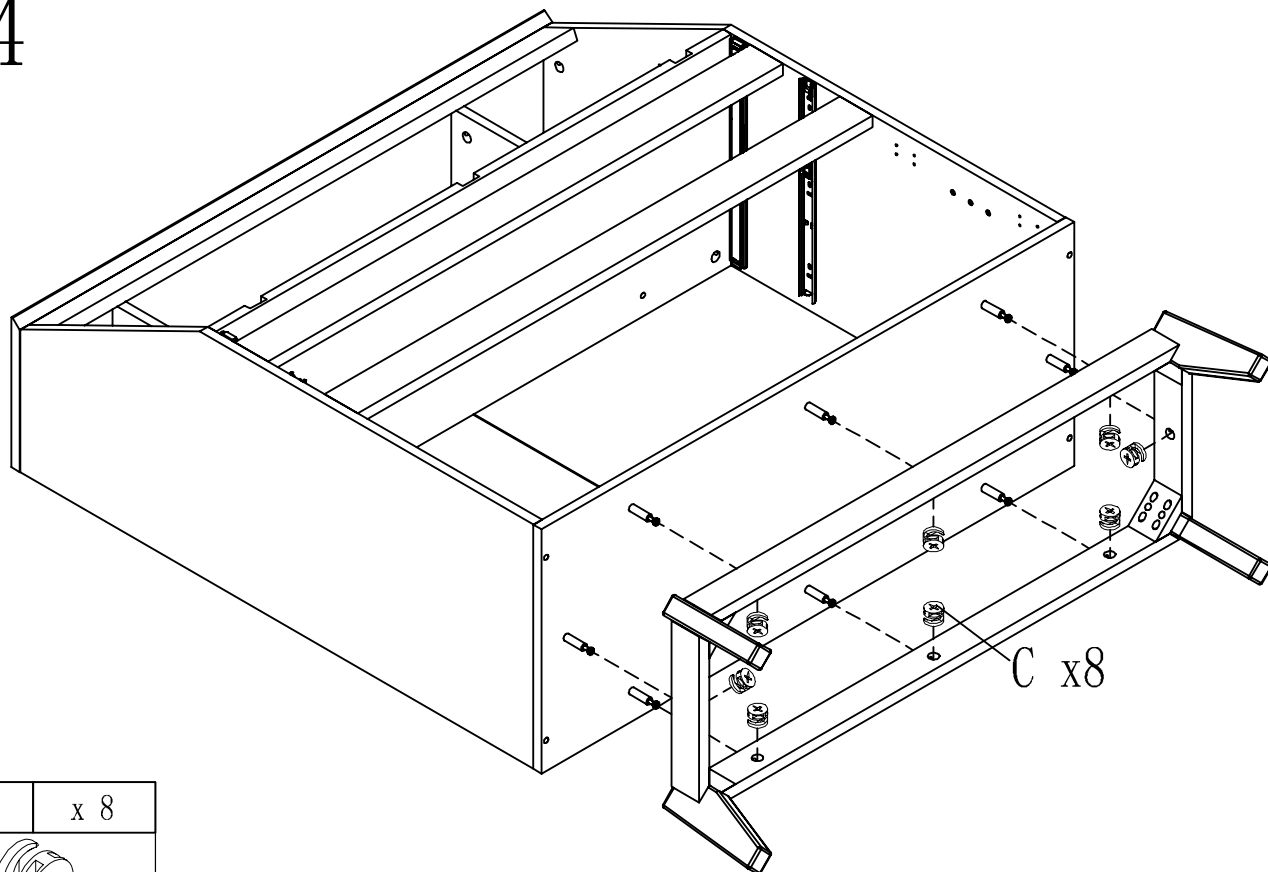
14



C	x 8
	
$\phi 15 * 12 \text{mm}$	

15

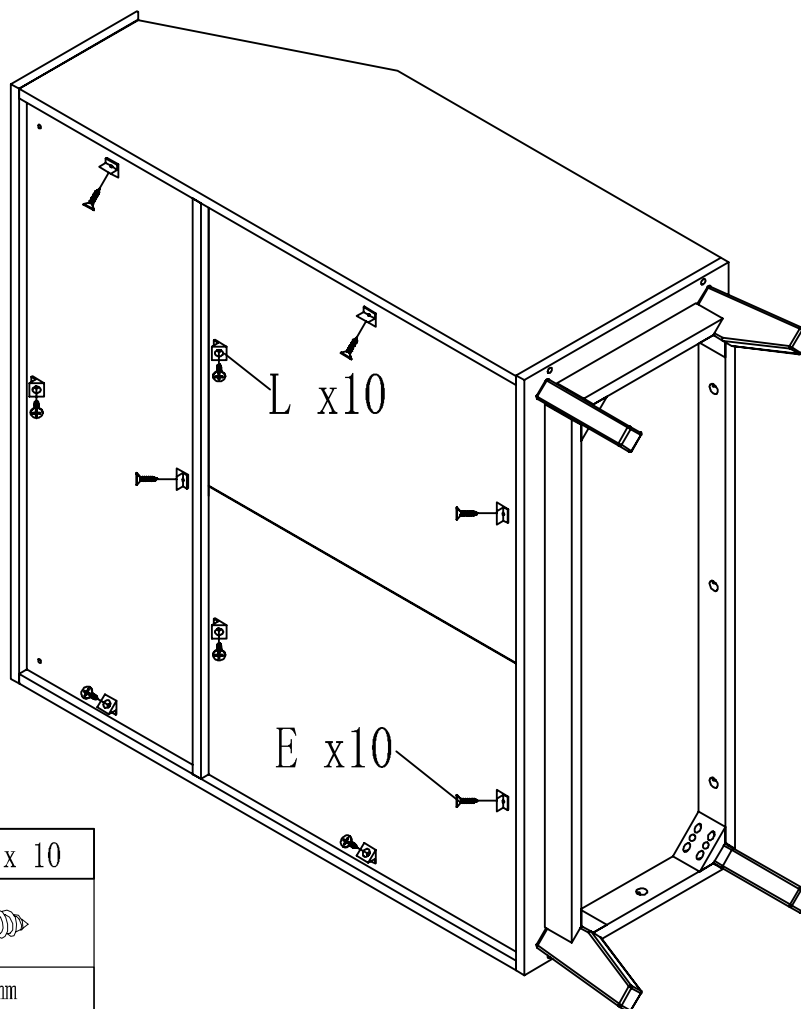

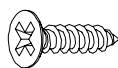
L	x 10	E	x 10
			
$14 * 14 * 9 \text{mm}$		$\phi 3.5 * 14 \text{mm}$	

16

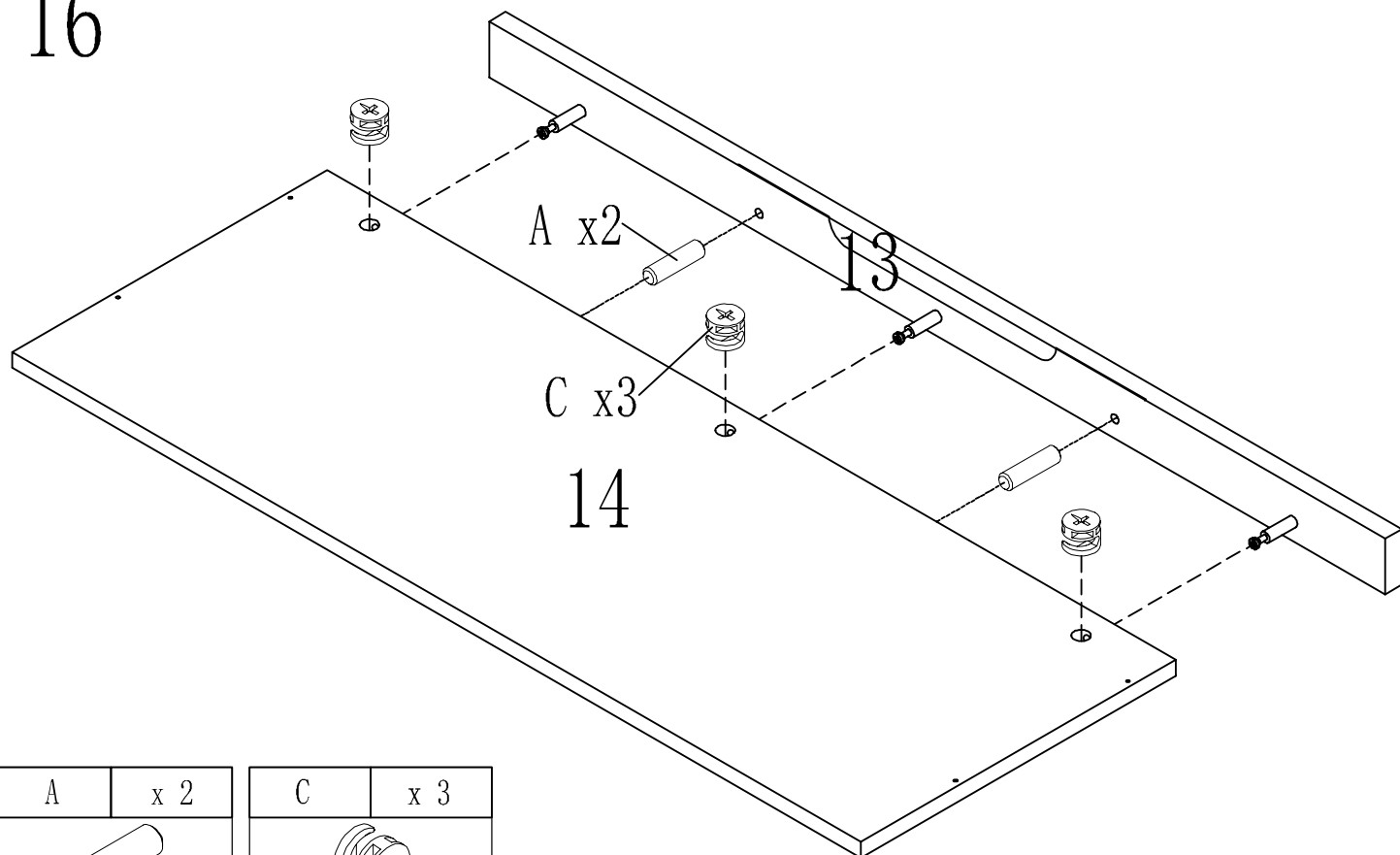

A	x 2
ø7.8*30mm	

C	x 3
ø15*12mm	

17

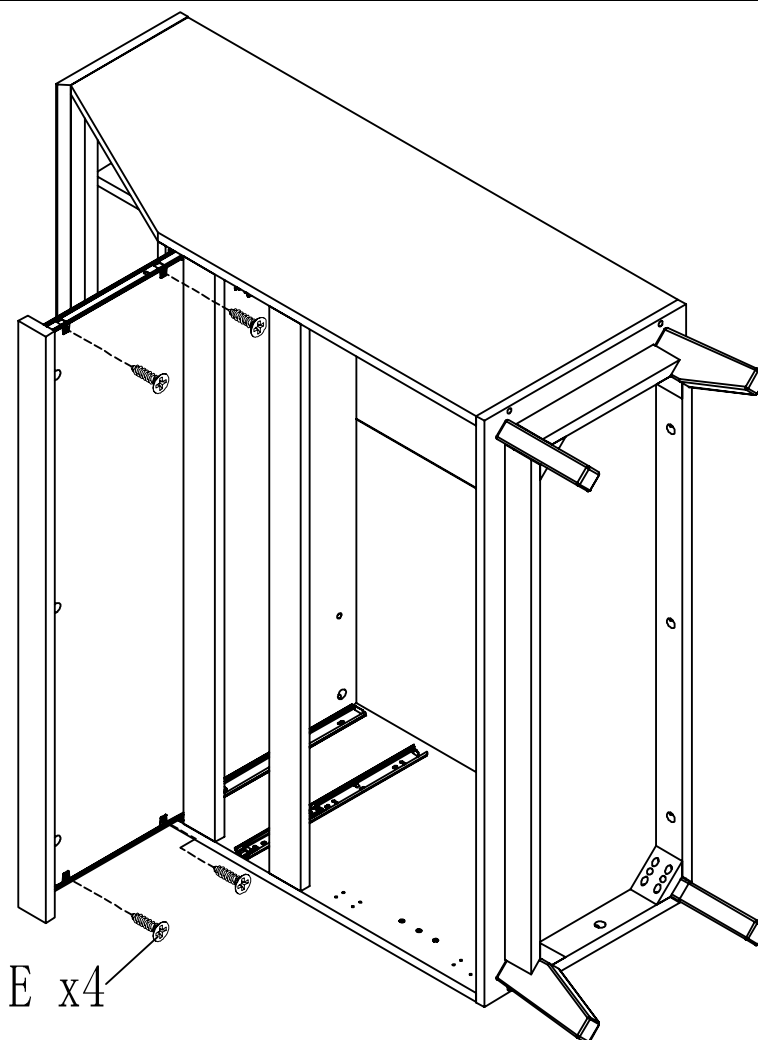

E	x 4
ø3.5*14mm	

18

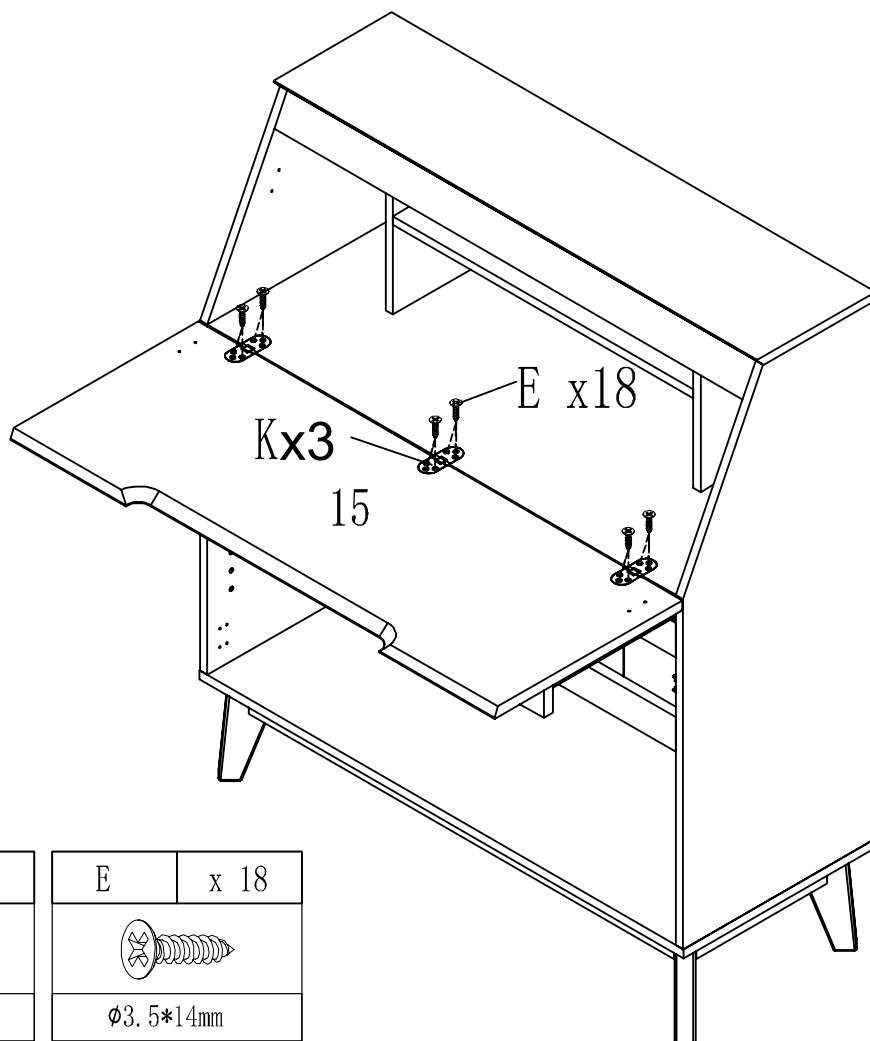

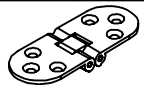

K	x 3
	
79*30*8mm	

E	x 18
	
Ø3.5*14mm	

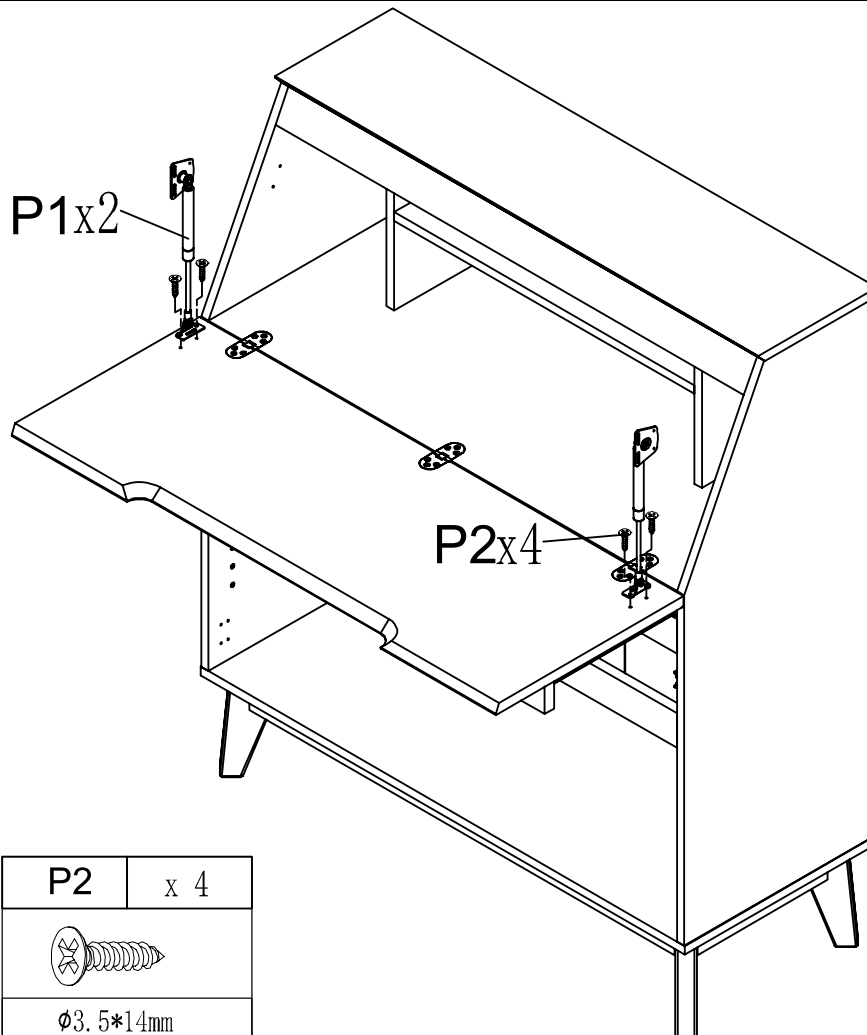
19

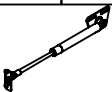

P1	x 2
	

P2	x 4
	
Ø3.5*14mm	

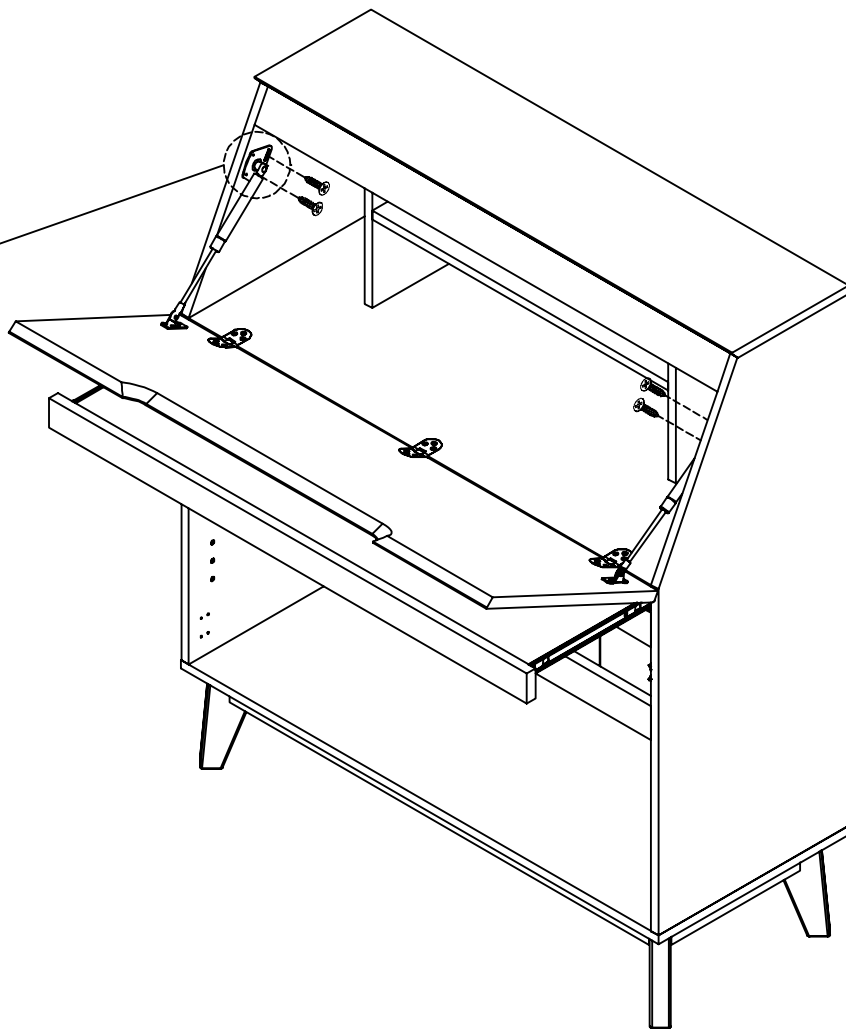
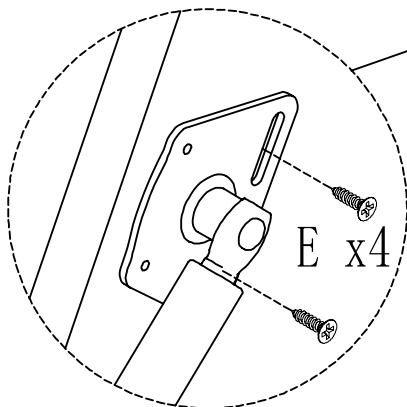

20

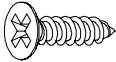

E	x 4
	
Ø3.5*14mm	

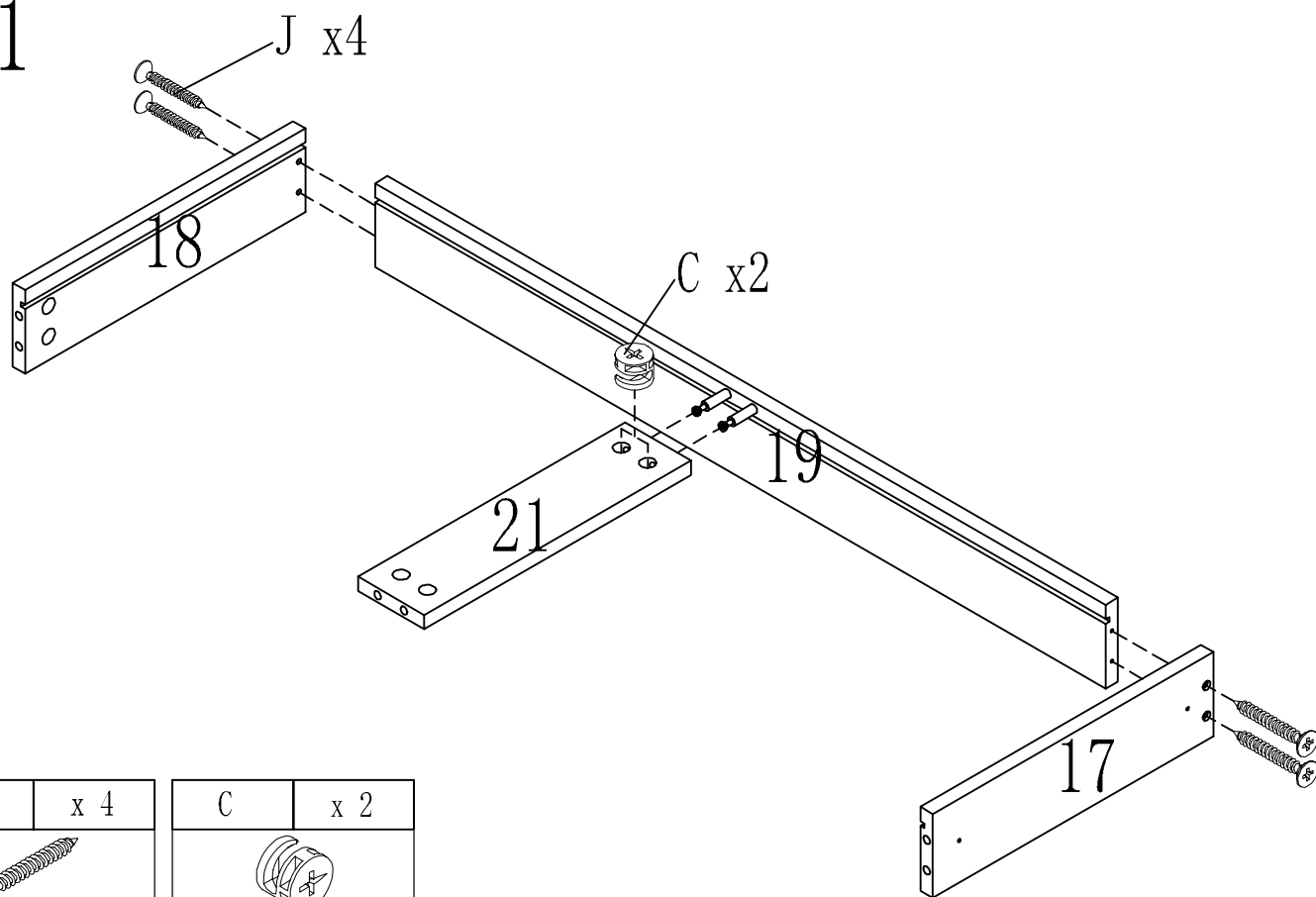
21

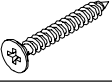

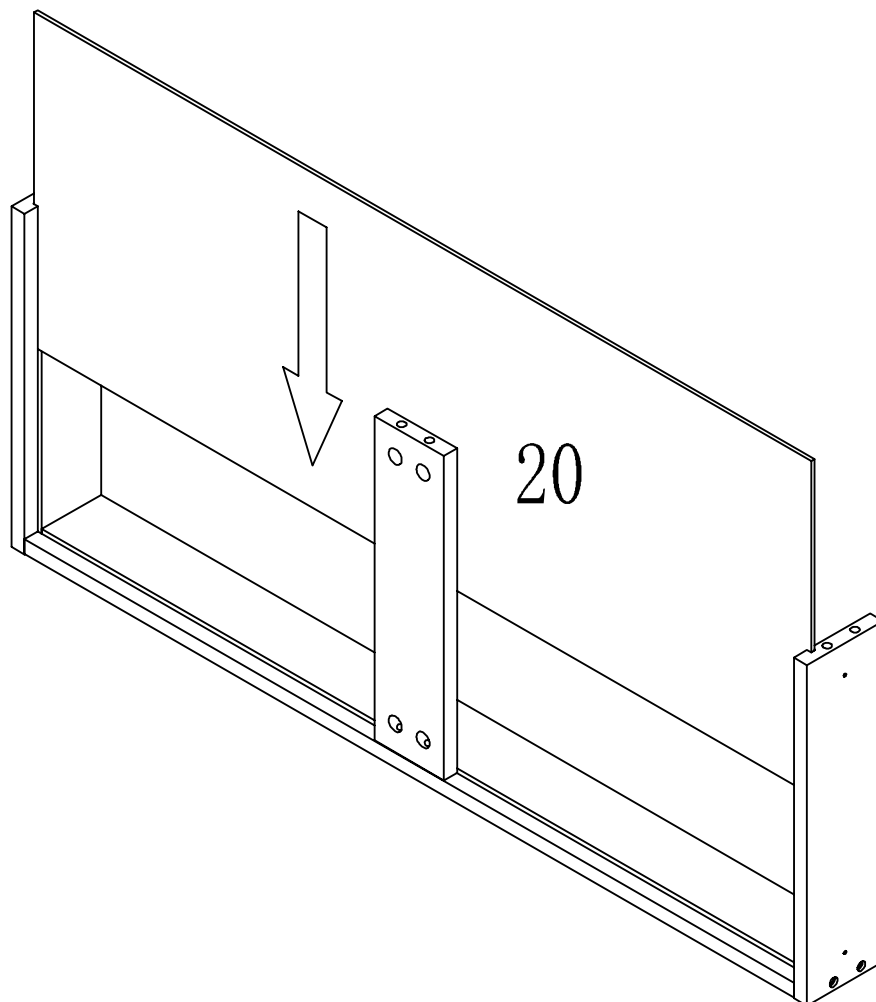

J	x 4	C	x 2
			
M4*35mm		Ø15*12mm	

22



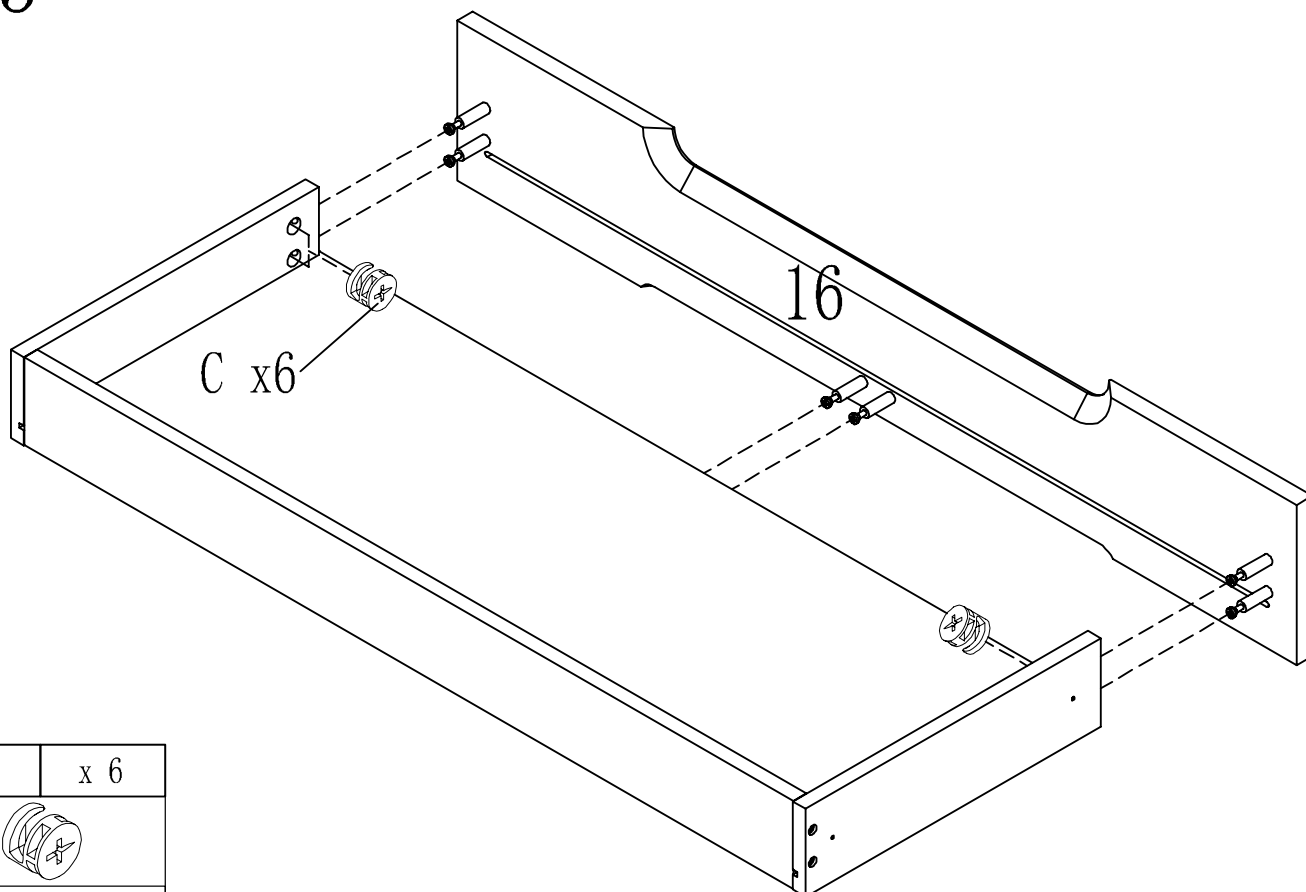

23

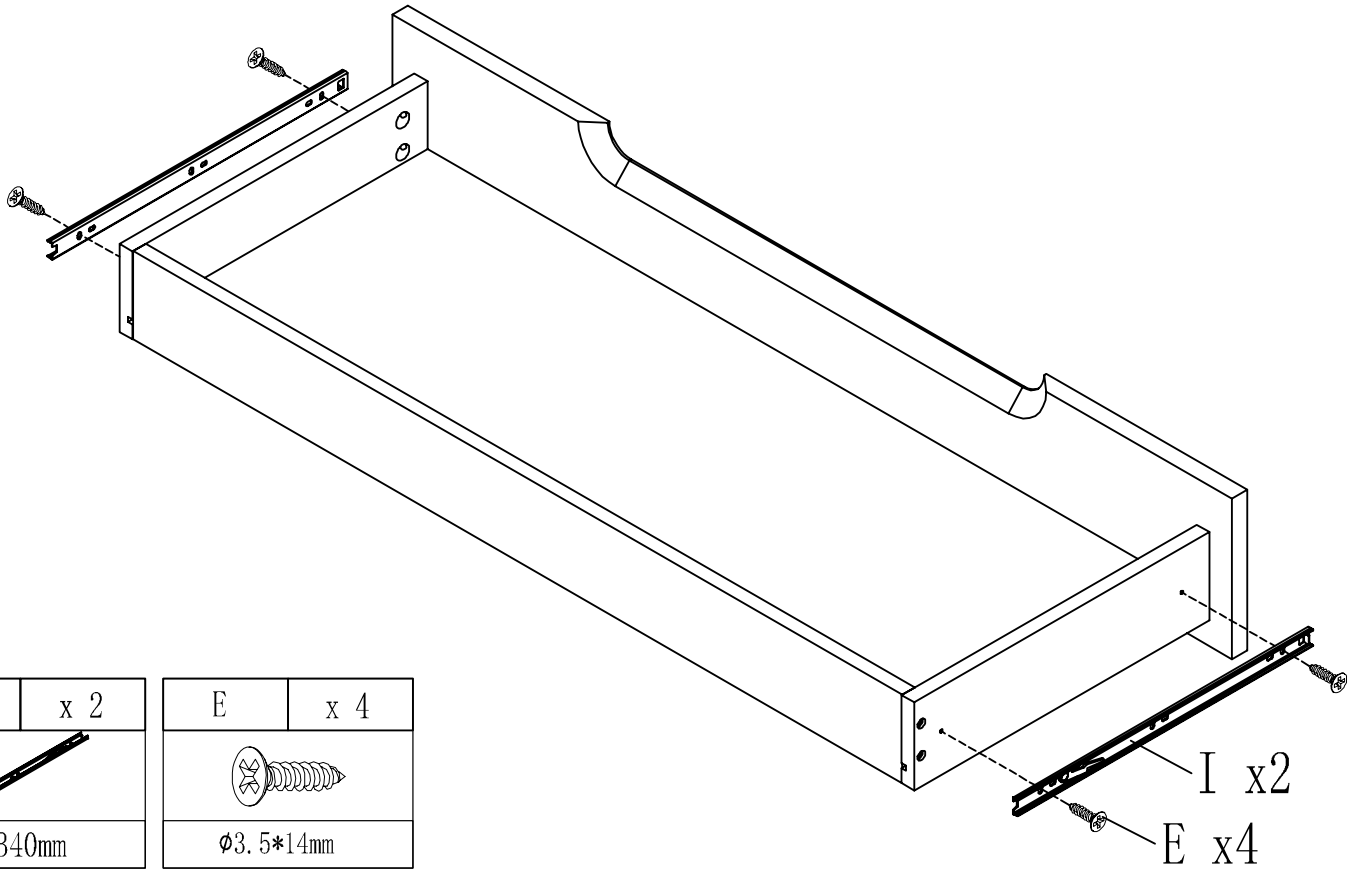

C	x 6
	
Ø15*12mm	

24

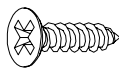

I	x 2	E	x 4
			
L340mm		Ø3.5*14mm	

25

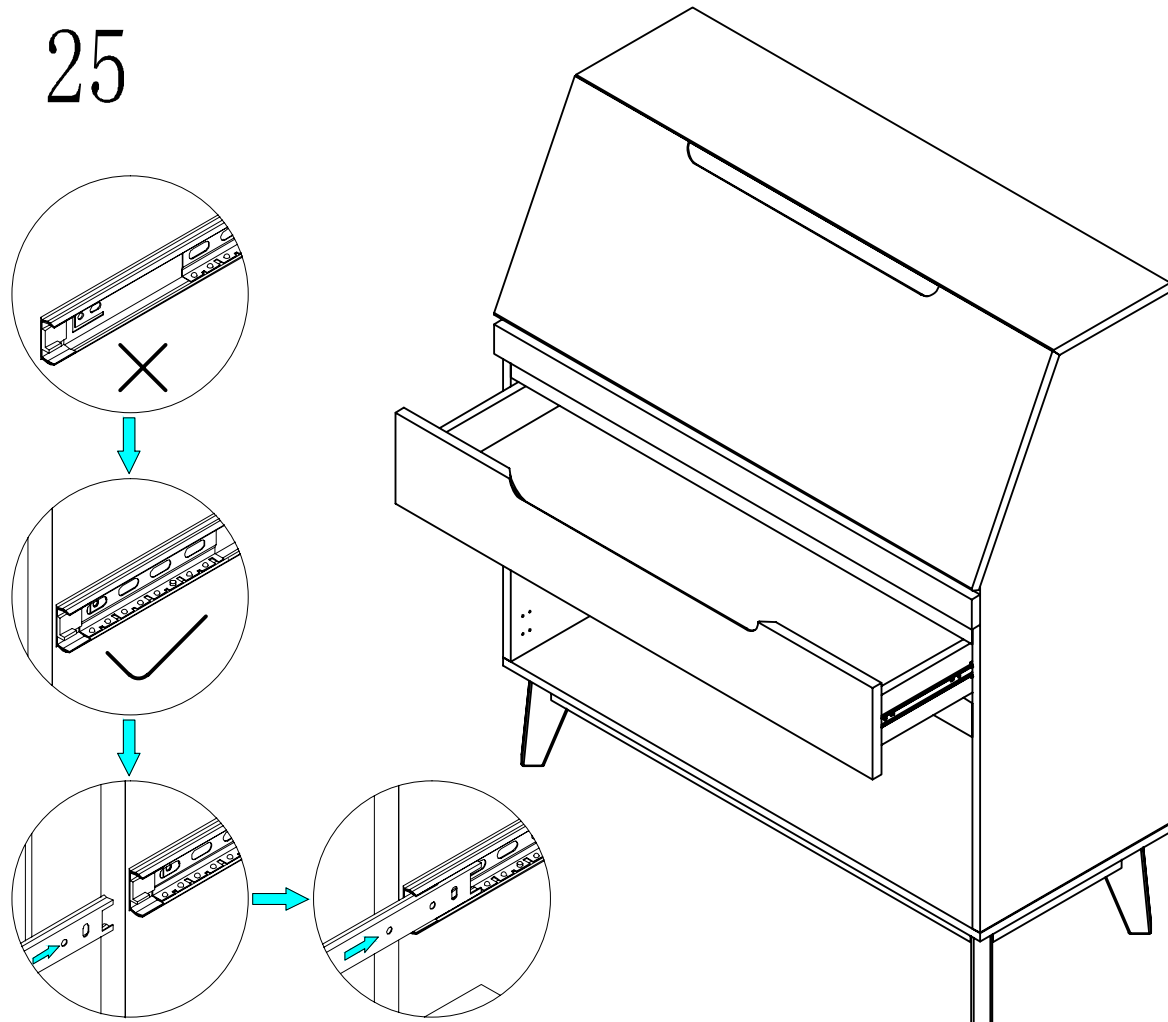

26

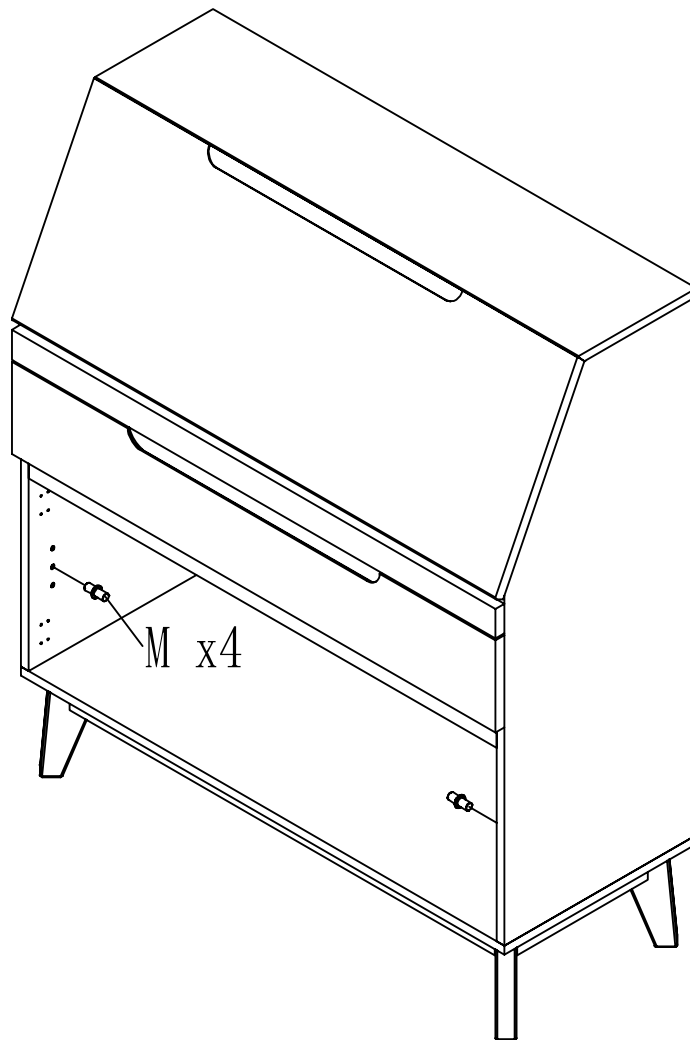

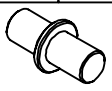
M	x 4
	
Ø5*16mm	

27

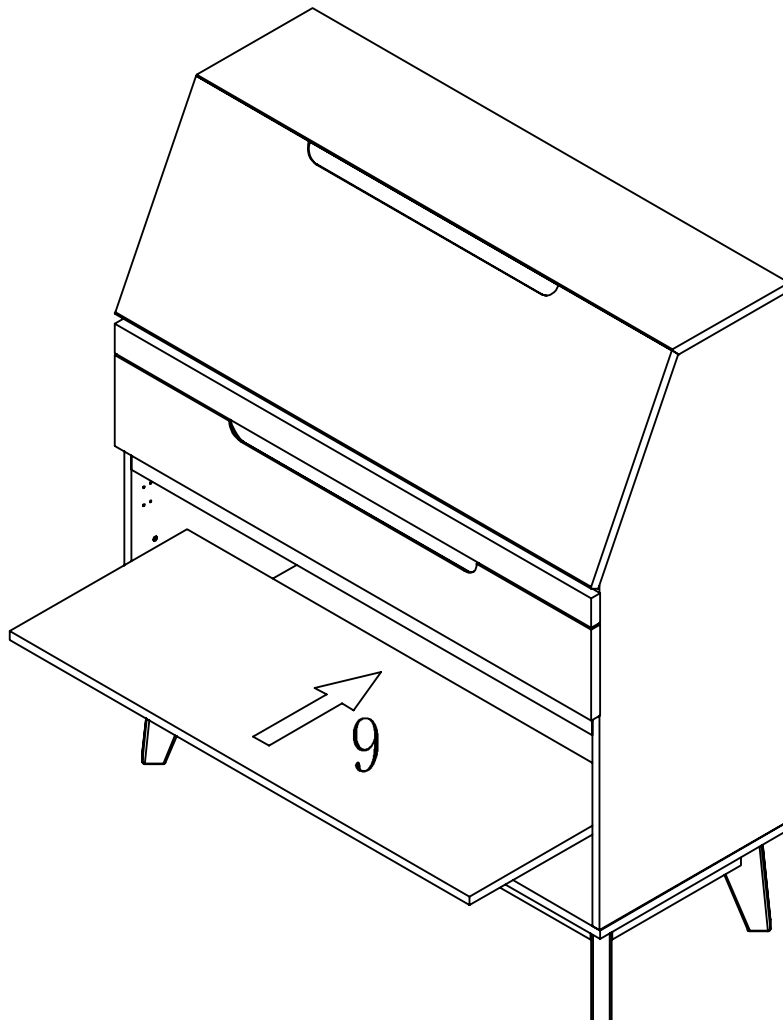

28

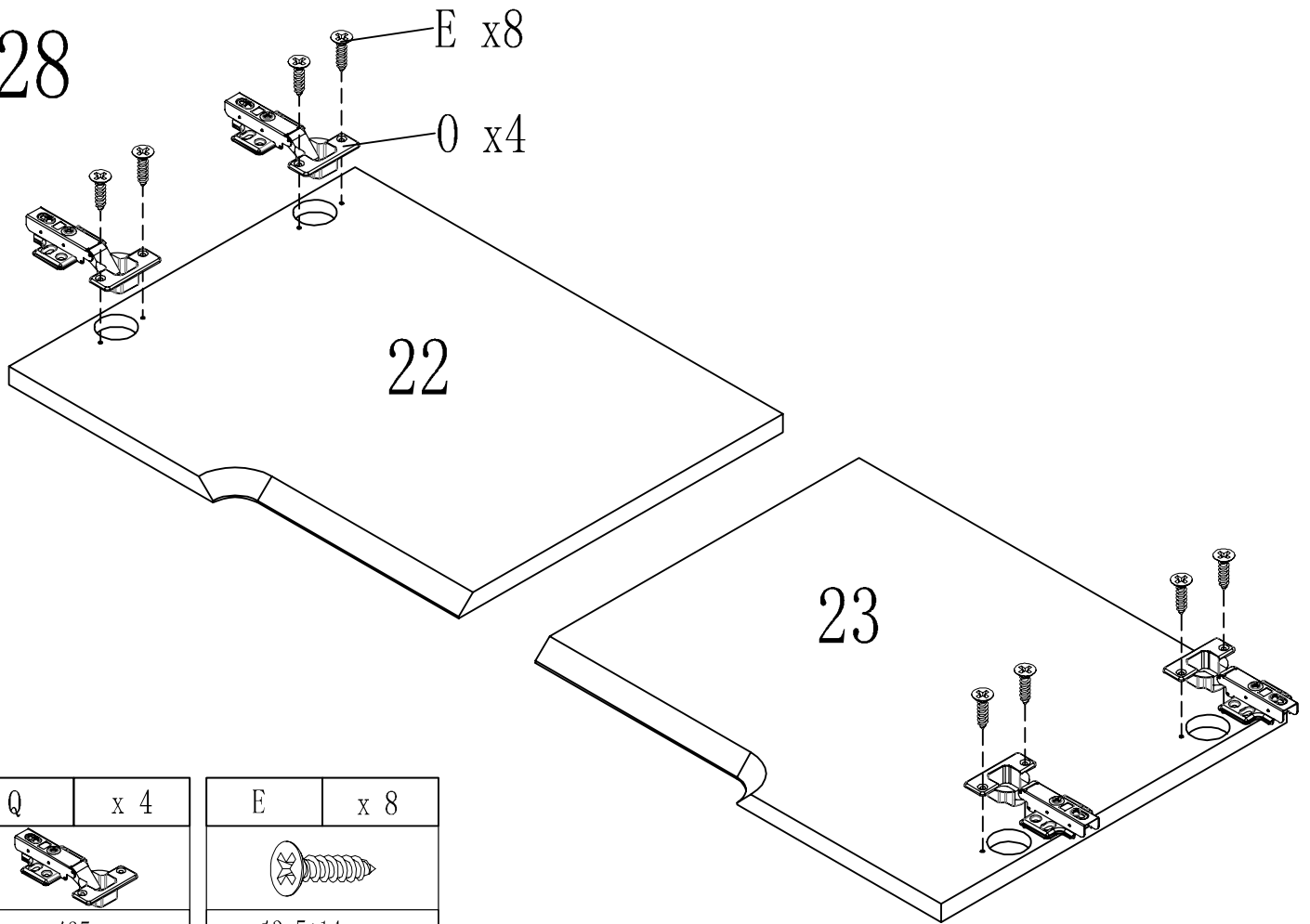

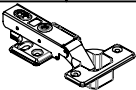
Q	x 4
	
ø35	

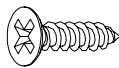
E	x 8
	
ø3.5*14mm	

29

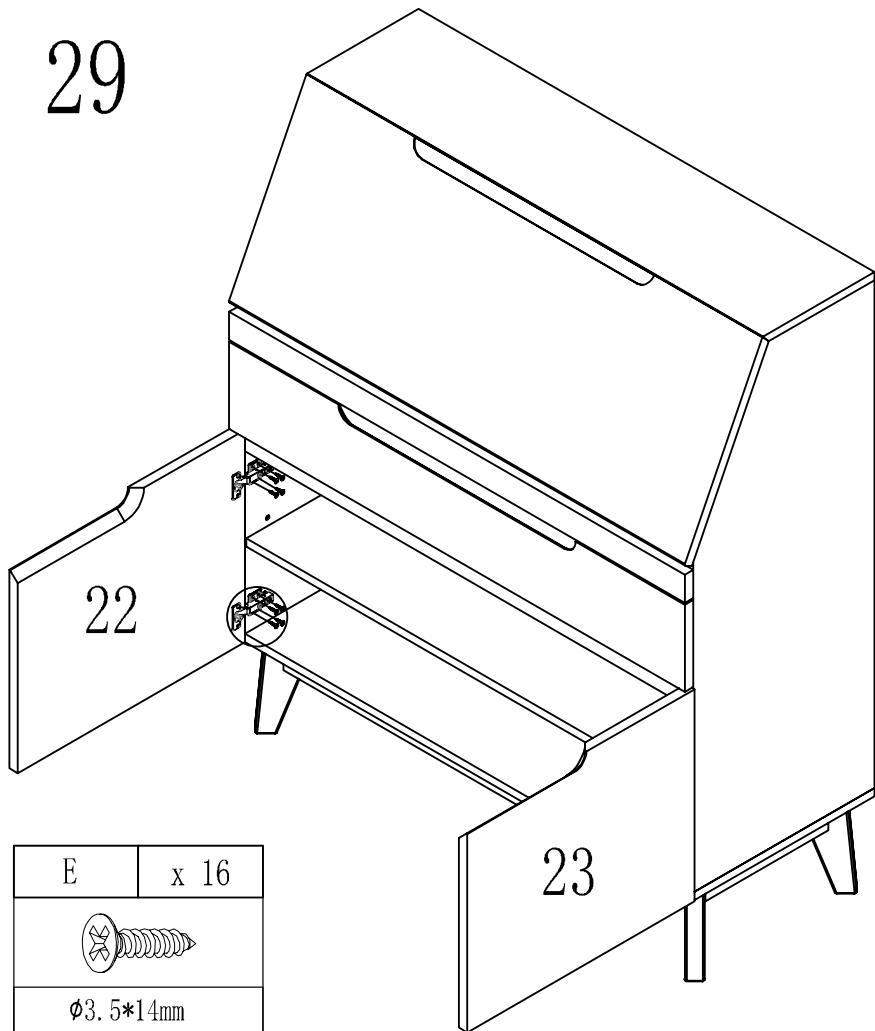

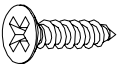
E	x 16
	
ø3.5*14mm	

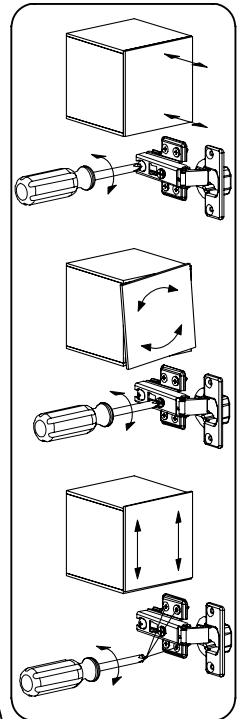
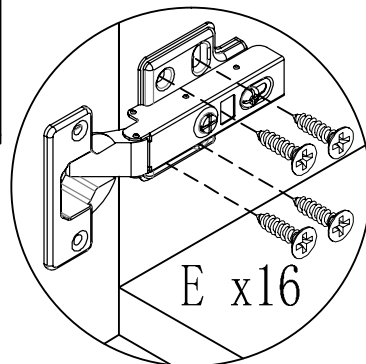

30

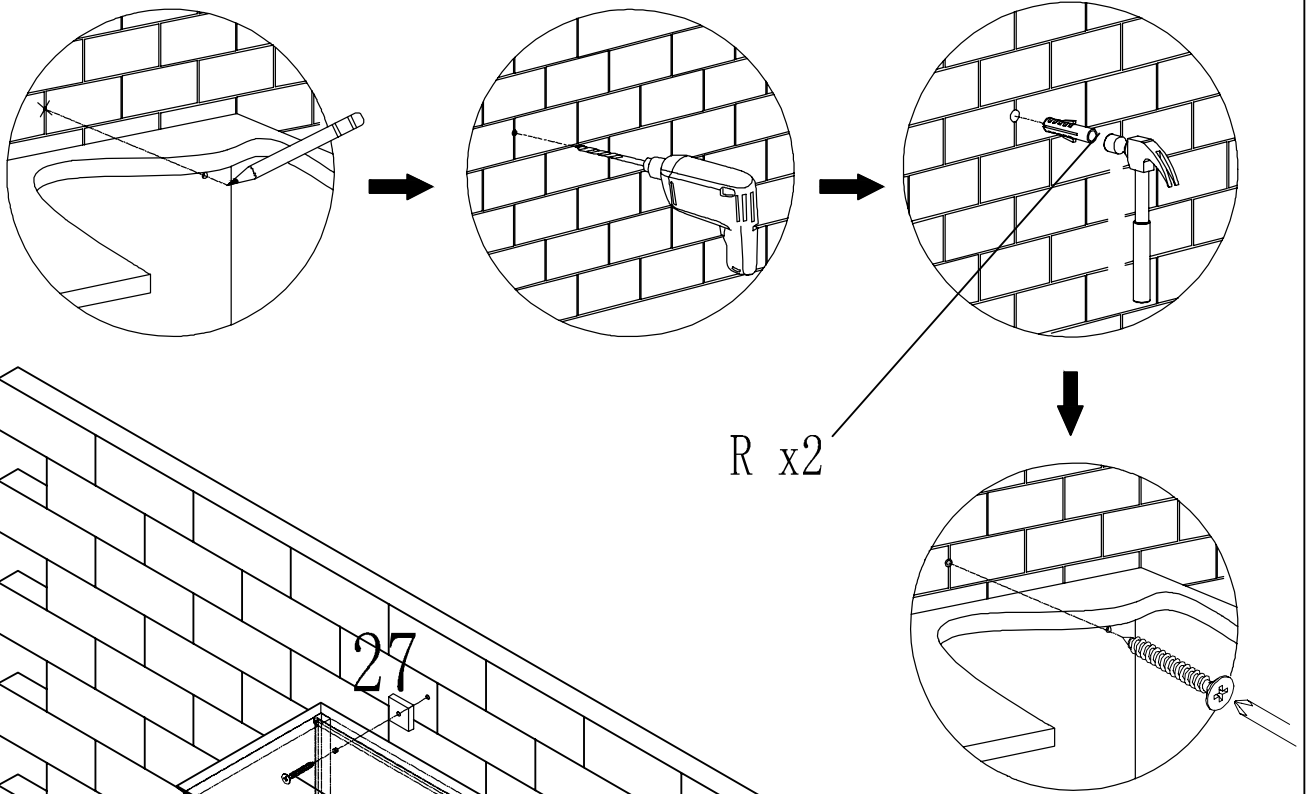

R x2

27

J x2

27

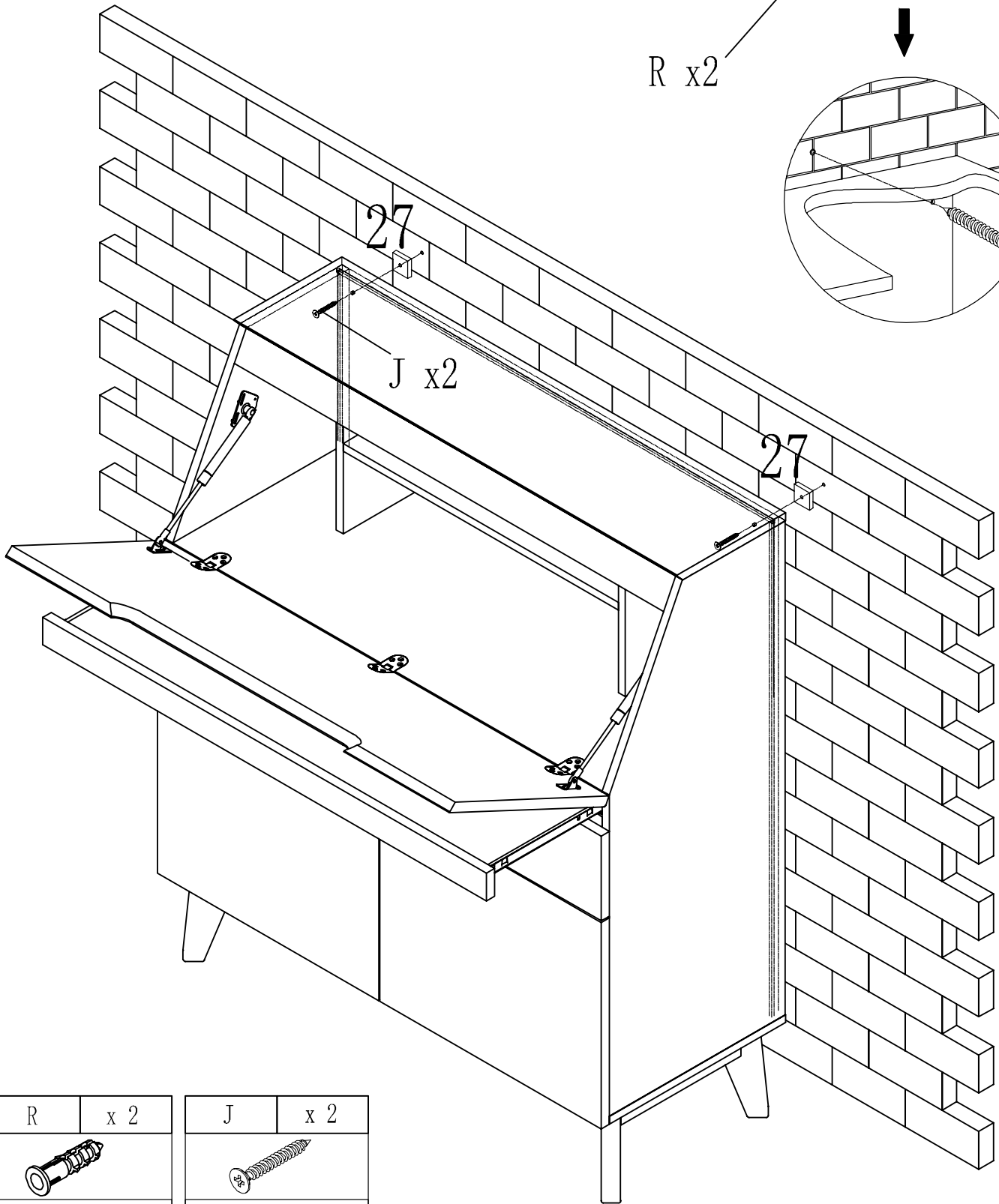

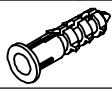
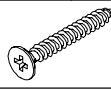
R	x 2	J	x 2
			
M8*40mm		M4*35mm	

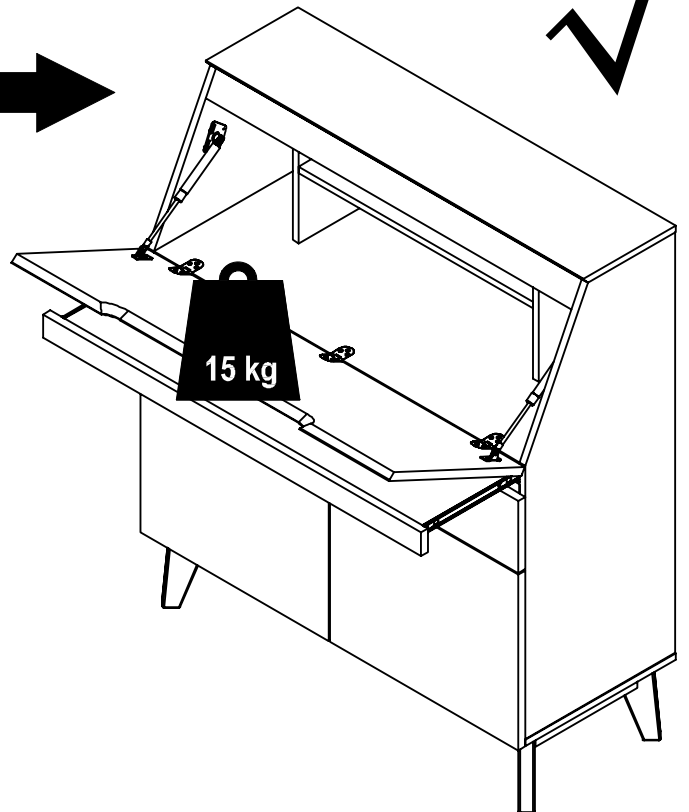
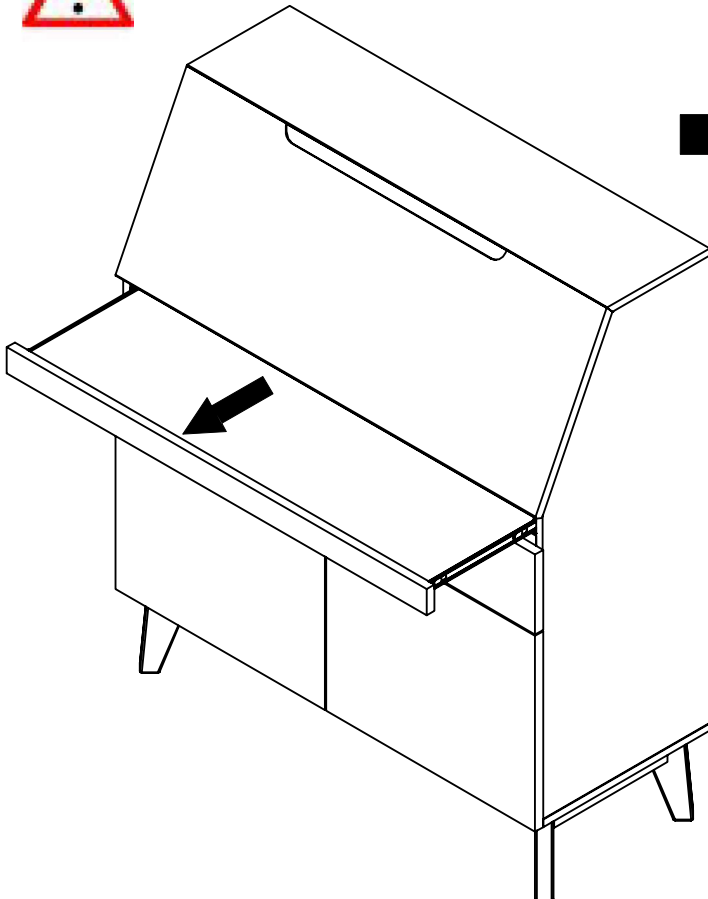
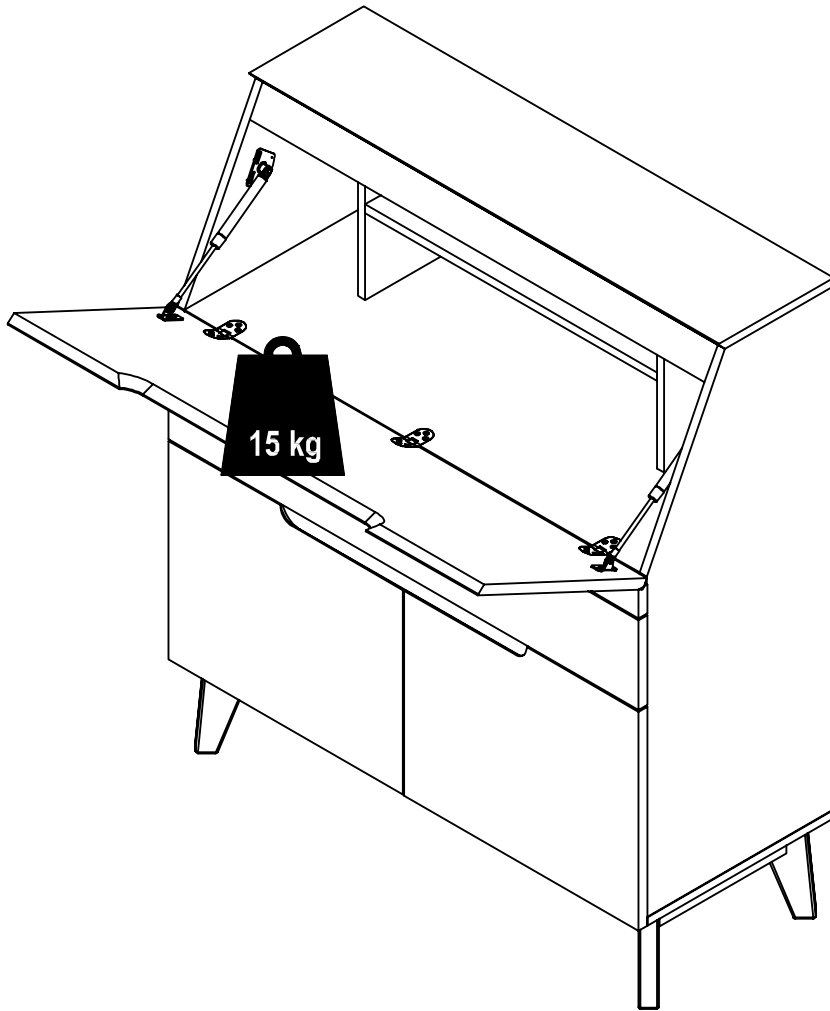

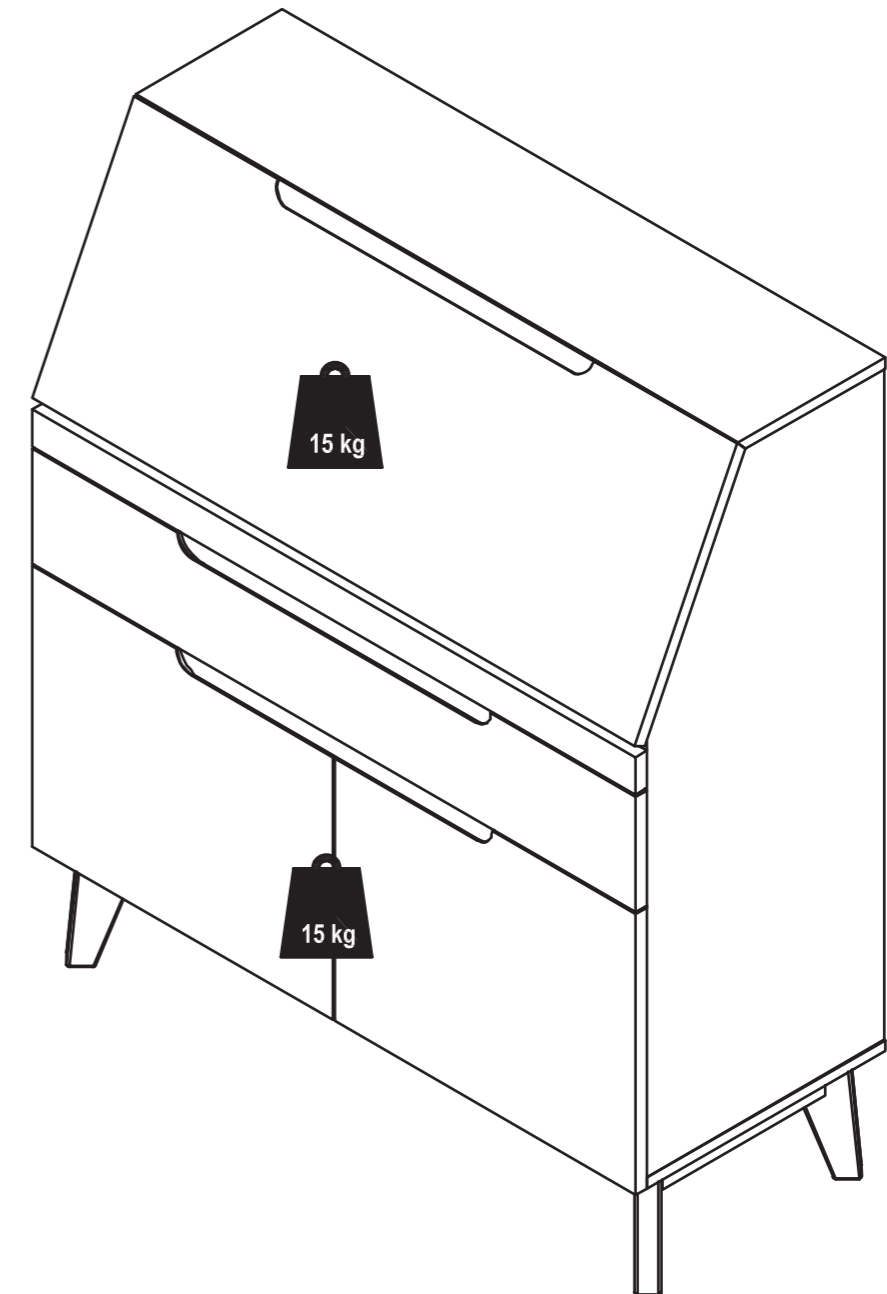

1000123519

Home24 SE

Otto-Ostrowski-Str.3 | 10249 Berlin | Deutschland
Made in China

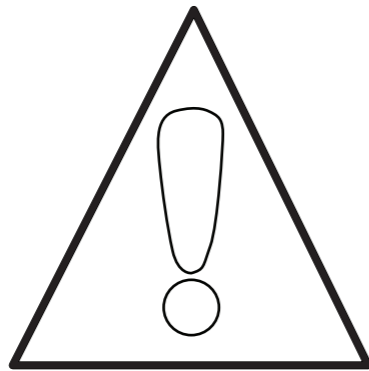

Pflegehinweise • Care Instructions • Conseil d'entretien • Onderhoudsinstructies • Istruzioni per l'uso

DEUTSCH

BESCHICHTETES HOLZ
Verwenden Sie ein antistatisches Staubtuch für die tägliche Pflege. Lauwarme Seifenlauge gegen leichte Verschmutzungen. Verwenden Sie keine scheuernden Reiniger, Wachse oder Möbelpolituren. Melaminharzbeschichtungen mit Waschbenzin und einem Fensterleder reinigen.

FRANÇAIS

BOIS LAMELLÉ
Utiliser un chiffon antistatique pour l'entretien quotidien. Eau savonneuse tiède contre les saletés légères. Ne pas utiliser de produit décapant, de cire ou d'encaustique. Nettoyer les couches de résine de mélamine avec du white-spirit et une peau de chamois.

ITALIANO

LEGNO LAMELLARE
Utilizzare un panno antistatico per la cura quotidiana. Per rimuovere piccole macchie utilizzare una soluzione di acqua e sapone tiepida. Non utilizzare detergenti abrasivi, cere o lacche per mobili. Pulire le superfici in resina melamminica con un panno di camoscio e una soluzione con benzina per uso domestico.

ENGLISH

LAMINATED WOOD
Use antistatic dusters for daily care. Use lukewarm suds to remove light staining. Do not use abrasive detergents, any kind of wax, or furniture polish. Melamine resin can be cleaned best with cleaning solvents in combination with a chamois leather.

NEDERLANDS

MULTIPLEX
Gebruik een antistatische doek voor het dagelijks schoonmaken van het artikel. U kunt lauw water en zeep gebruiken voor licht vervuilde plekken. Gebruik geen schuurmiddelen, was of meubelglans. Melaminehars kan het beste worden gereinigd met wasbenzine in combinatie met een zeem.

DEUTSCH

Bitte benutzen Sie dieses Produkt ausschließlich für seinen ihm zugedachten Zweck.

Kastenmöbel können umfallen und zu schweren Verletzungen führen. Bitte nutzen Sie das beigefügte Wandbefestigungsset, um diese Gefahr zu vermeiden.

Schrauben und Dübel zur Wandbefestigung nicht enthalten.

FRANÇAIS

Utiliser uniquement le produit pour son usage prévu!

Les éléments peuvent basculer et provoquer de graves blessures. Afin d'éviter tout danger, veuillez utiliser le kit de fixation murale joint.

Les vis et chevilles pour montage mural ne sont pas incluses.

ITALIANO

Utilizzare il prodotto unicamente per la destinazione d'uso prevista.

Mobili a scaffale possono cadere e procurare gravi lesioni. La invitiamo a utilizzare il kit di fissaggio incluso per assicurare i mobili alla parete e evitare pericoli.

Viti e tasselli per il montaggio a muro non sono inclusi.

ENGLISH

Use the product for its intended purpose only!

Free standing cabinets can tip over and cause severe harm. Please use attached wall-mount kit to avoid this hazard.

Screws and dowels for wall-mount are not included.

NEDERLANDS

Gebruik dit product alleen waarvoor het bedoeld is!

Vrijstaande kasten kunnen omvallen en letsel veroorzaken. Gebruik alstublieft de bijgeleverde wandmontagekit om letsel te voorkomen.

Schroeven en pluggen voor wandmontage zijn niet inbegrepen.

30



EN:buy dowel and screw.
 DE:Dübel und Schraube kaufen.
 NL:Dübel en Schraube kaufen.
 FR:Achetez des épingles et des vis.
 IT:Compra perni e viti.

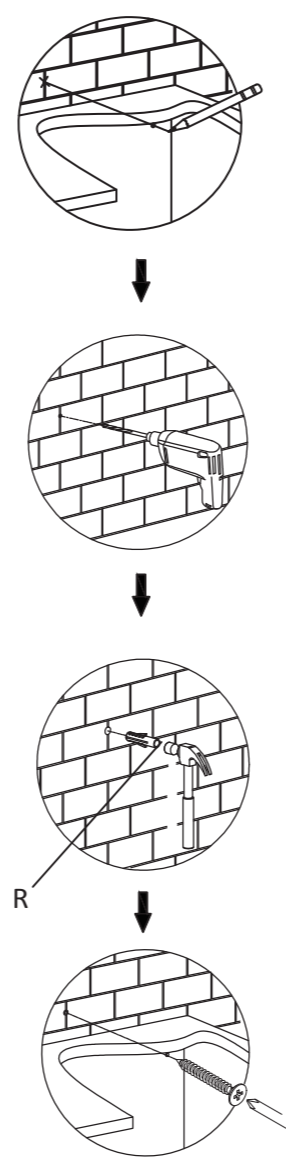
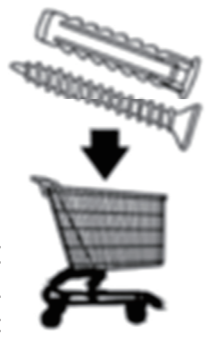
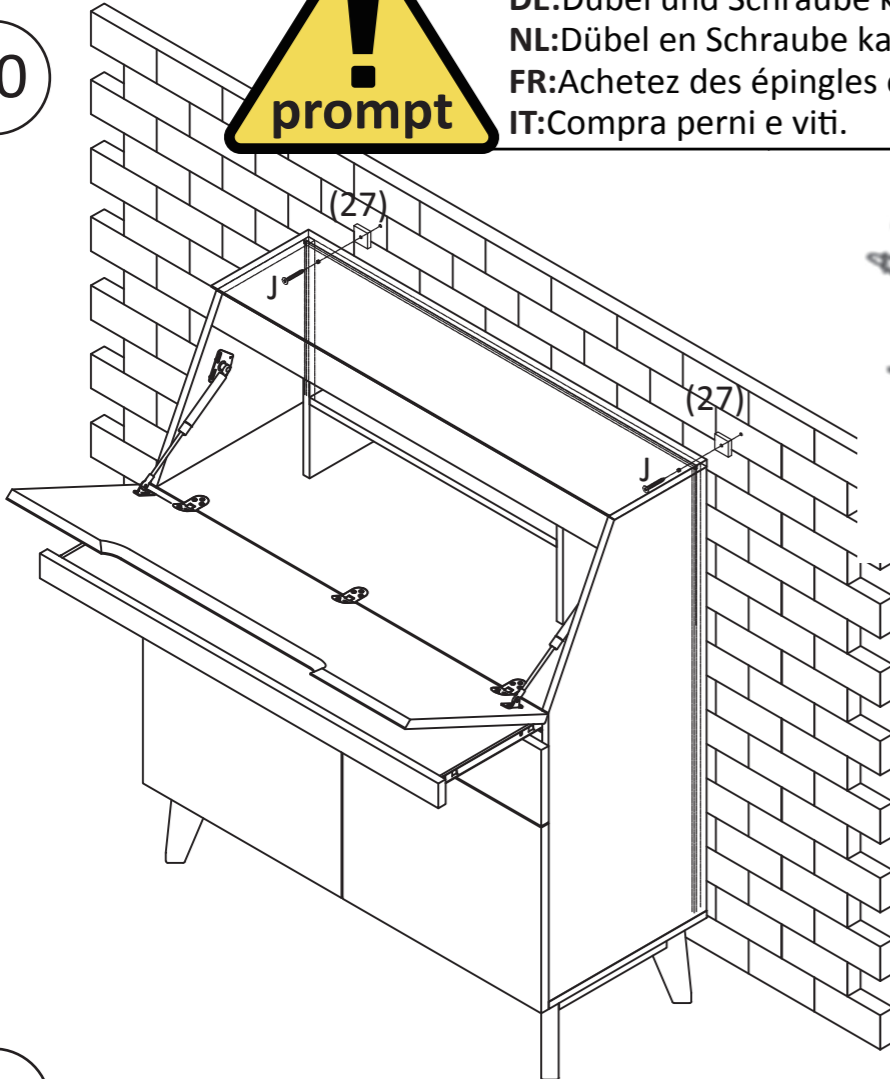

31

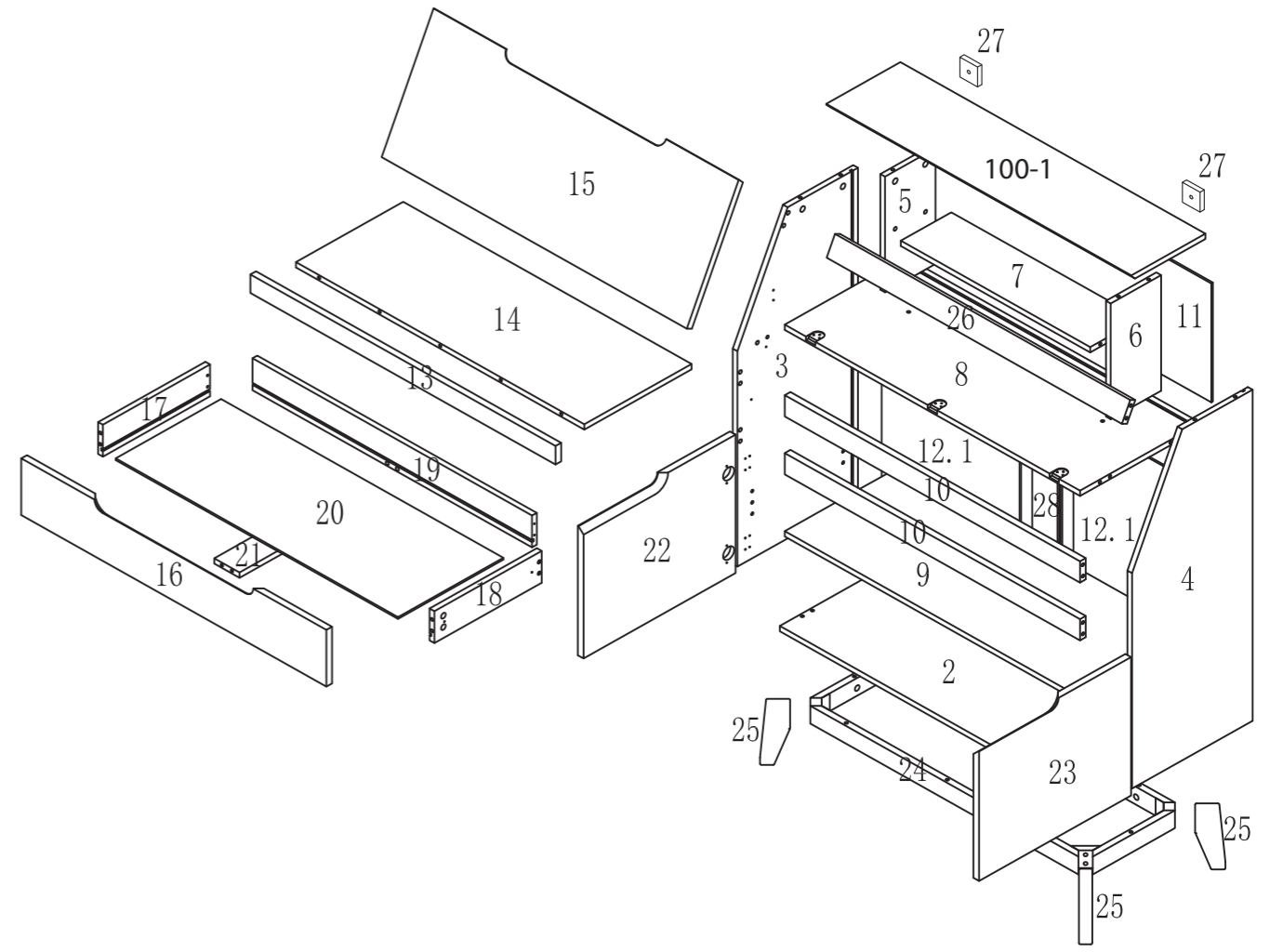
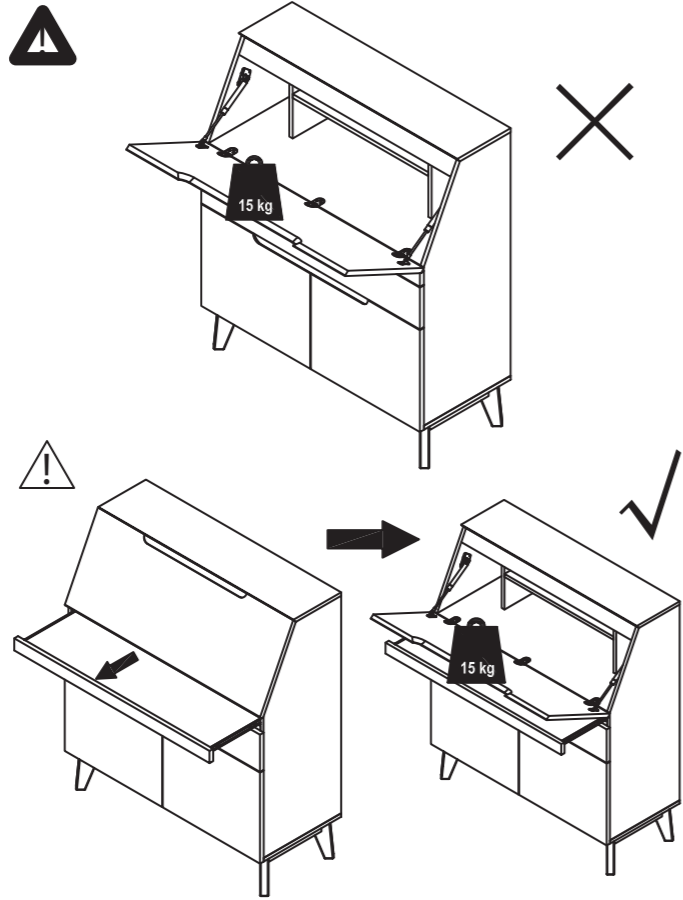

- | | | | | | | | |
|-----------------------|-----------------------|------------------------|------------------------|-----------------------|---------------------------|----------------|-------------------|
| AX 26
Ø 7.8 x 30mm | BX 45
6 x 36mm | CX 45
Ø 15 x 12mm | DX 10
7 x 50mm | EX 46
Ø 3.5 x 14mm | FX 1
L355mm | GX 1
L355mm | HX 2
L340mm |
| IX 2
L340mm | KX 3
79 x 30 x 8mm | LX 12
14 x 14 x 9mm | MX 4
Ø 5 x 14mm | NX 8
6 x 35mm | OX 8
Ø 16 x 6.5 x T1mm | PX 2 | PY 4 |
| QX 4
Ø 35mm | SX 1
M4 | TX 24
Ø 4 x 15mm | UX 1
25 x 25 x 15mm | VX 2
Ø 4 x 14mm | WX 4
Ø 3.5 x 12mm | XX 4
6*25mm | YX 4
Ø 10x10mm |
| ZX 4
4 x 30mm | | | | | | | |

25

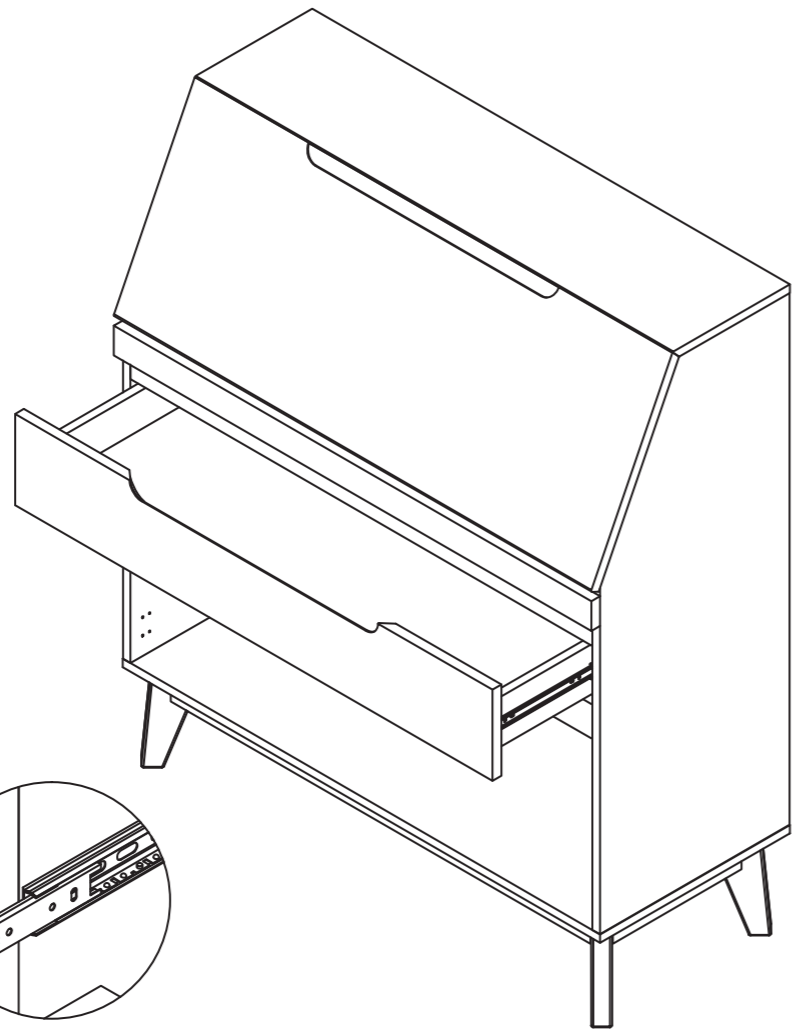
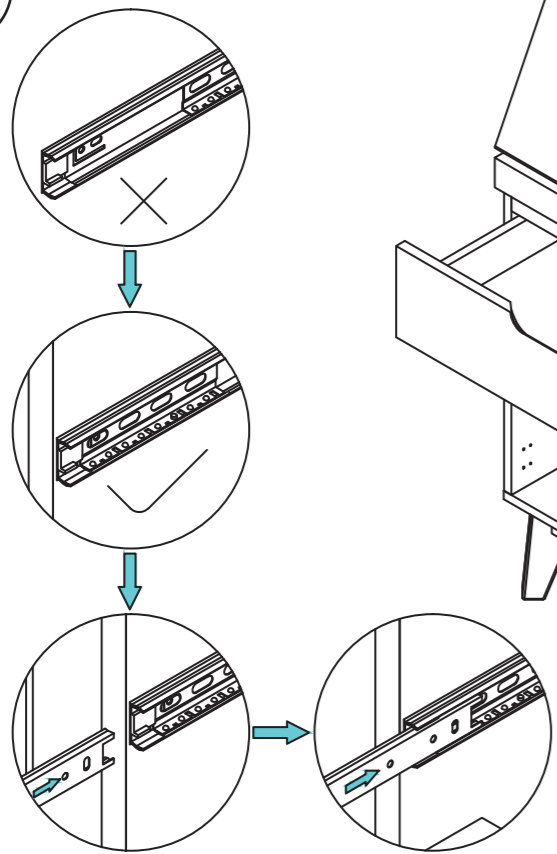

26

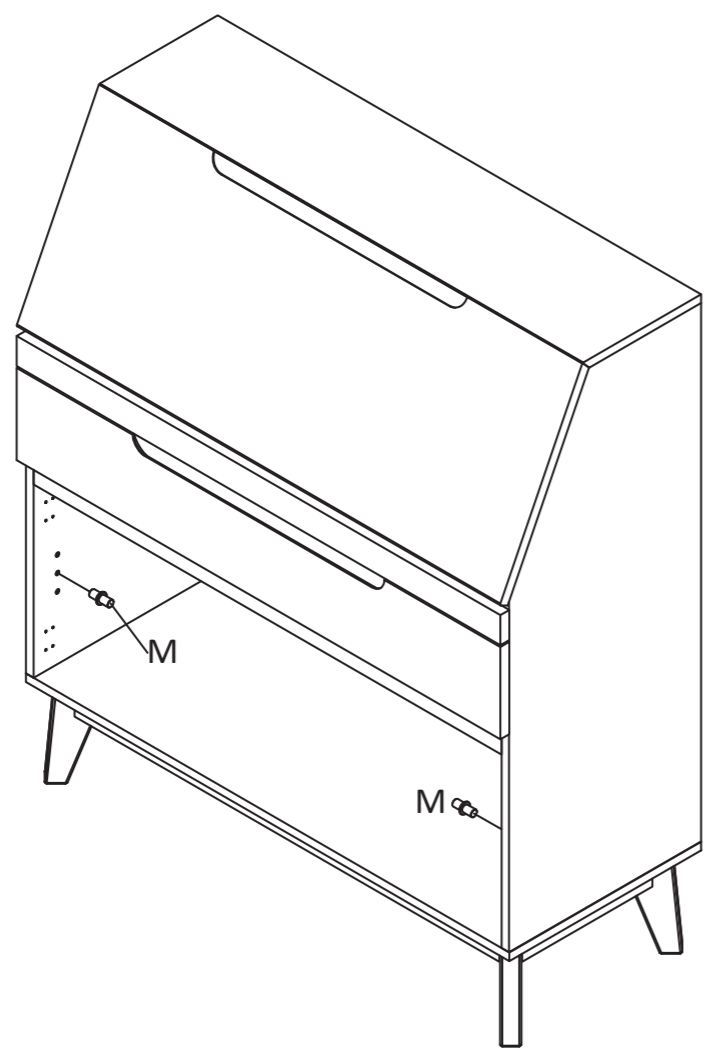

3

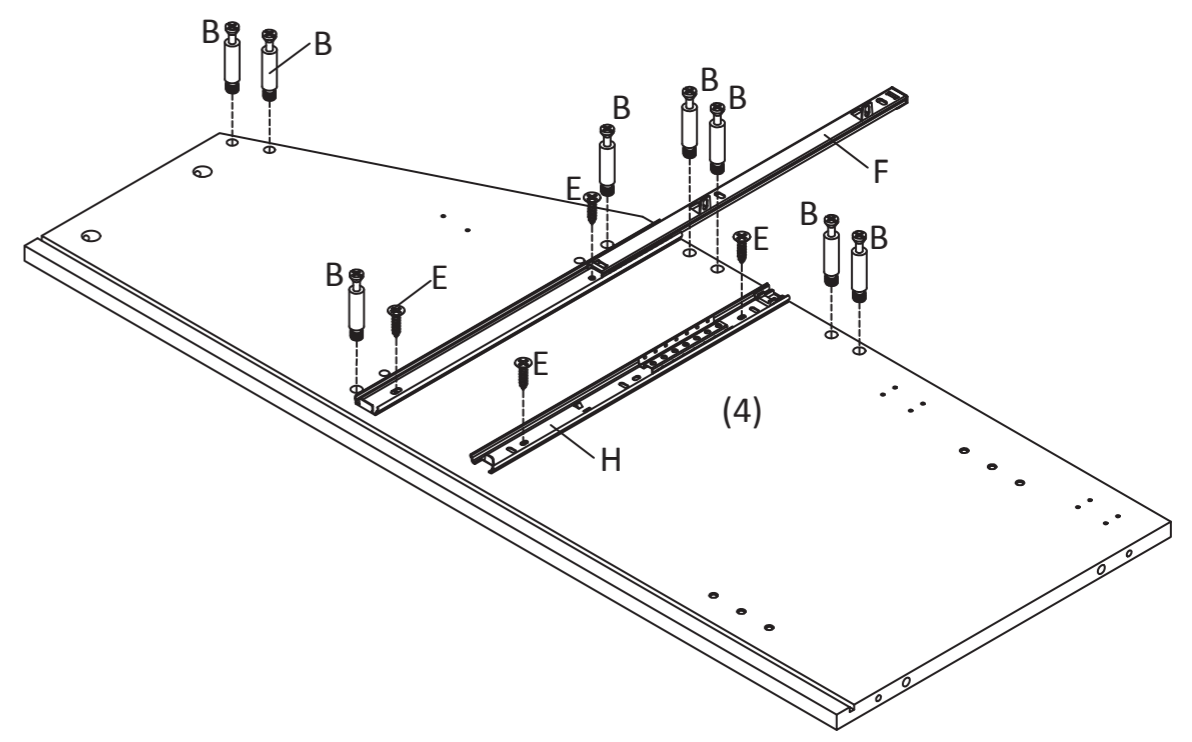

4

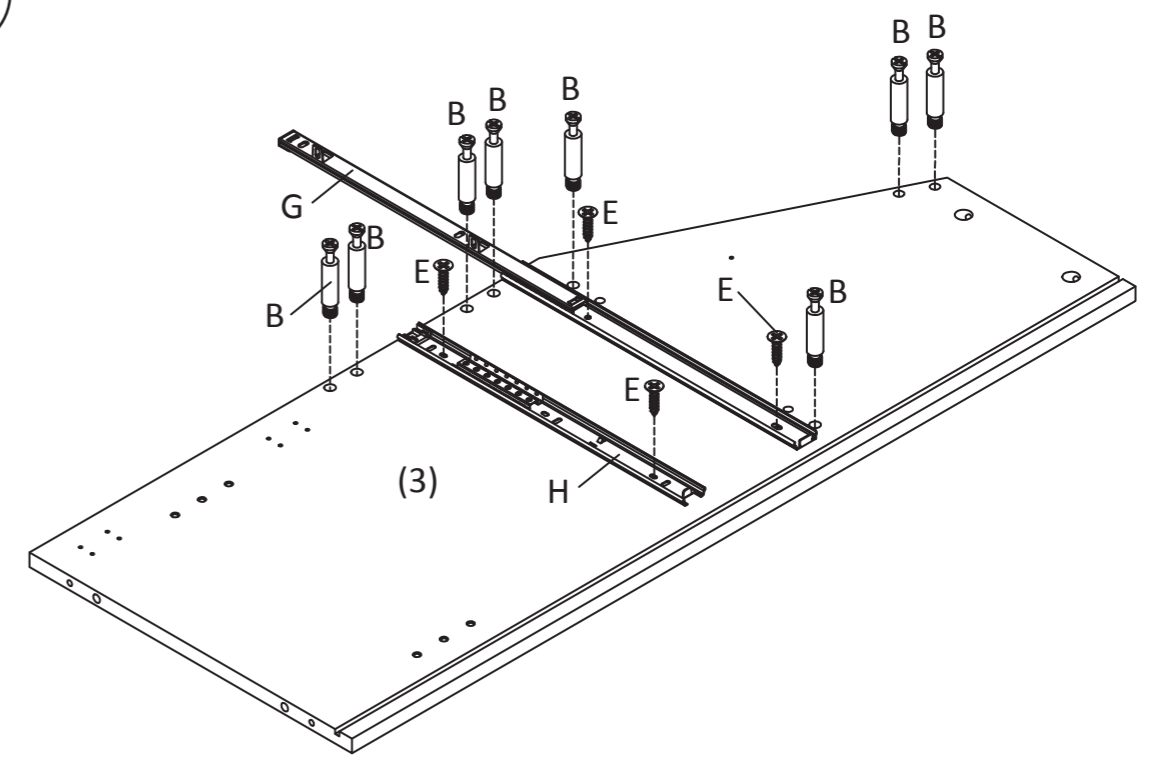

5

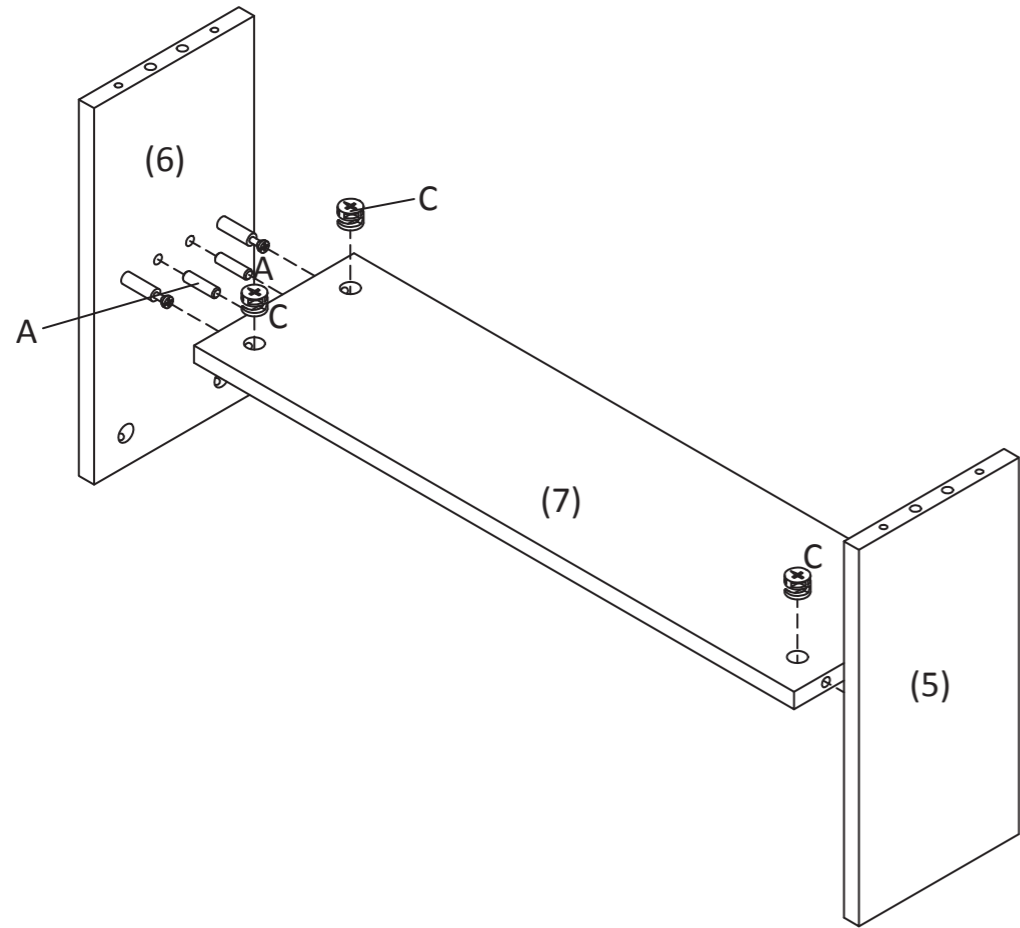

6

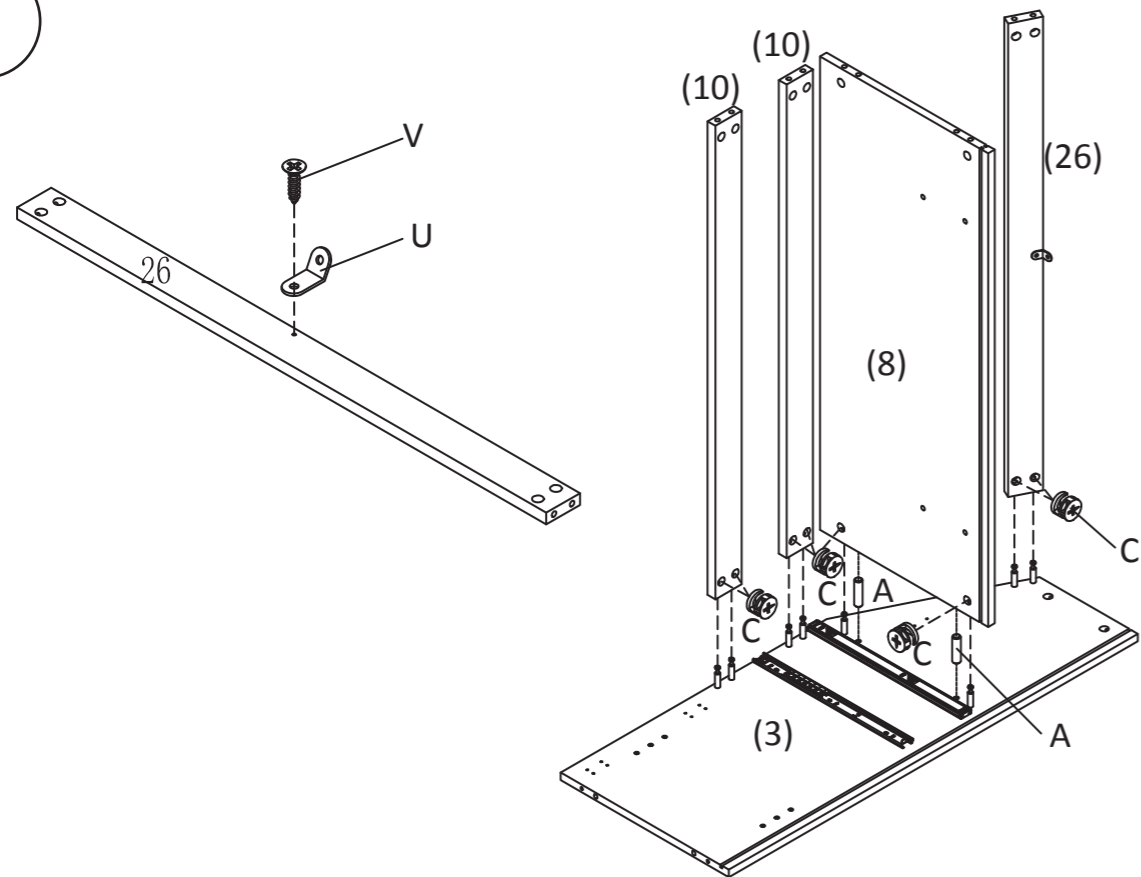

23

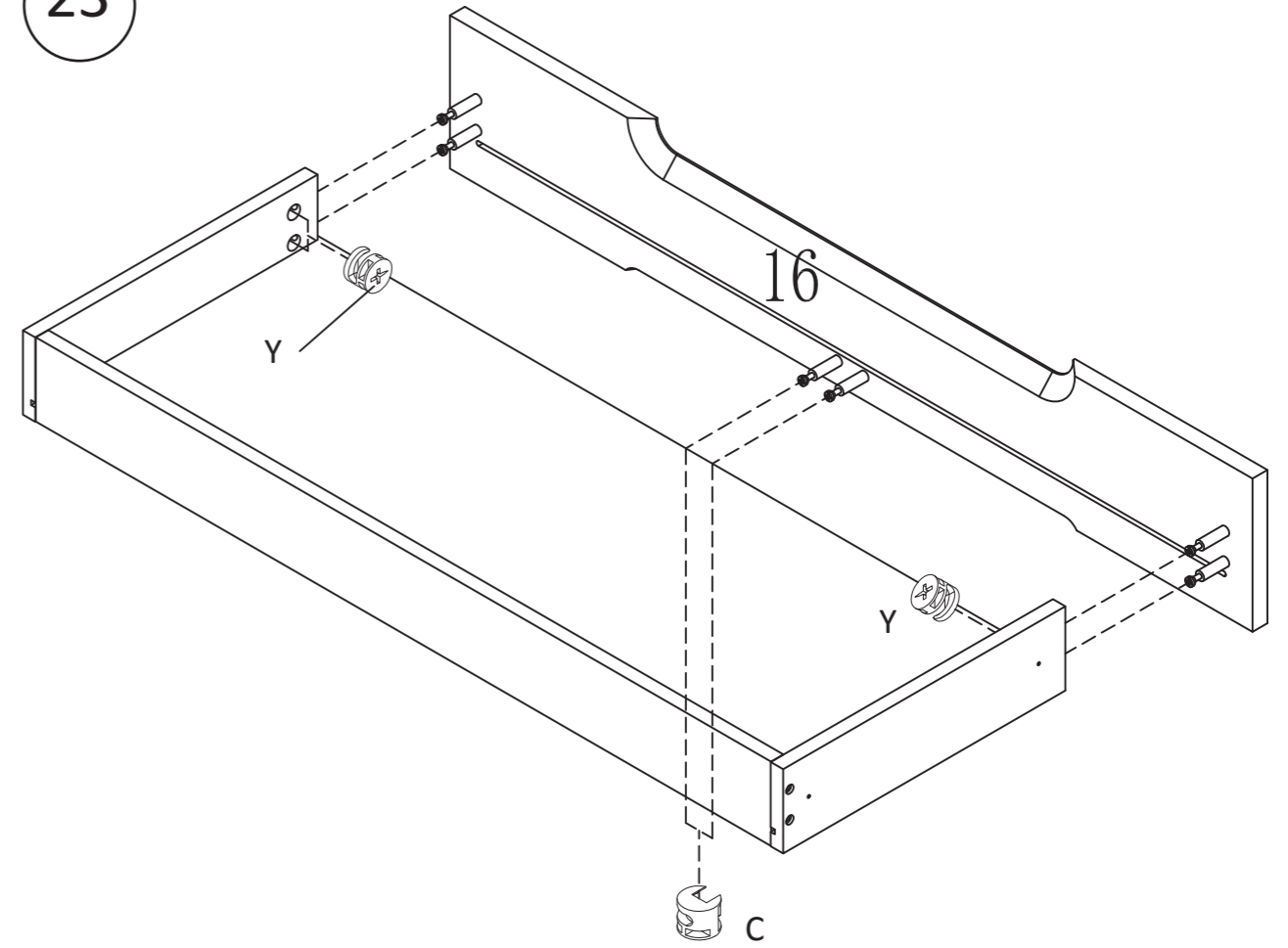

24

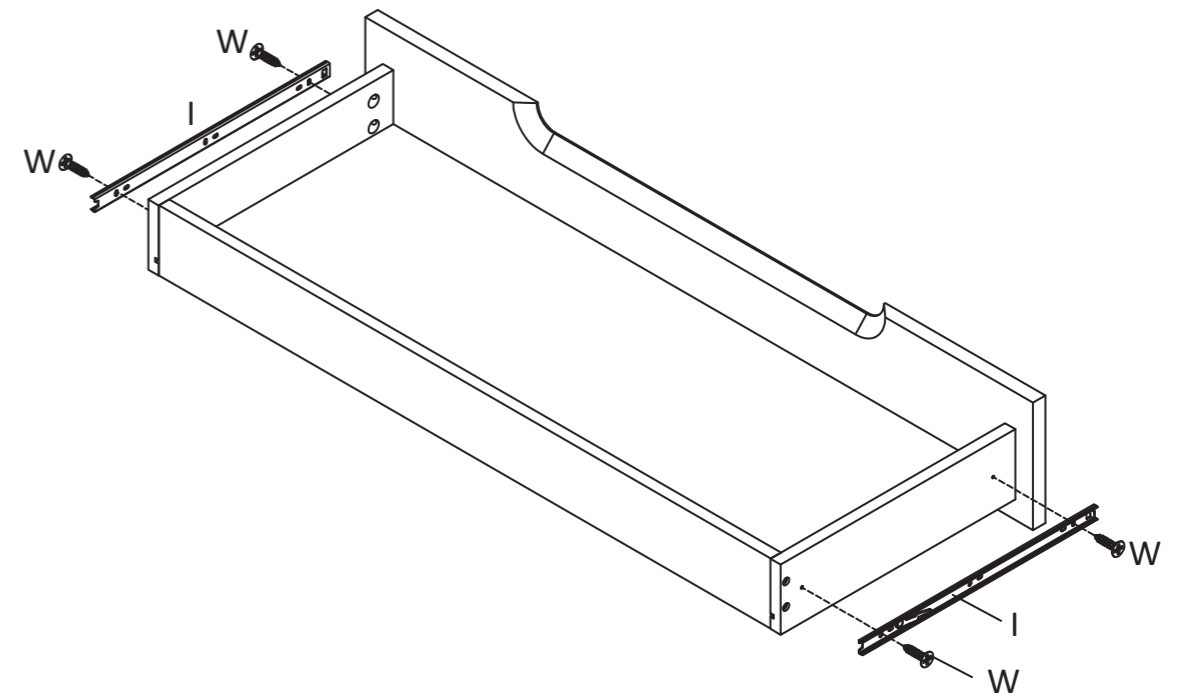

21

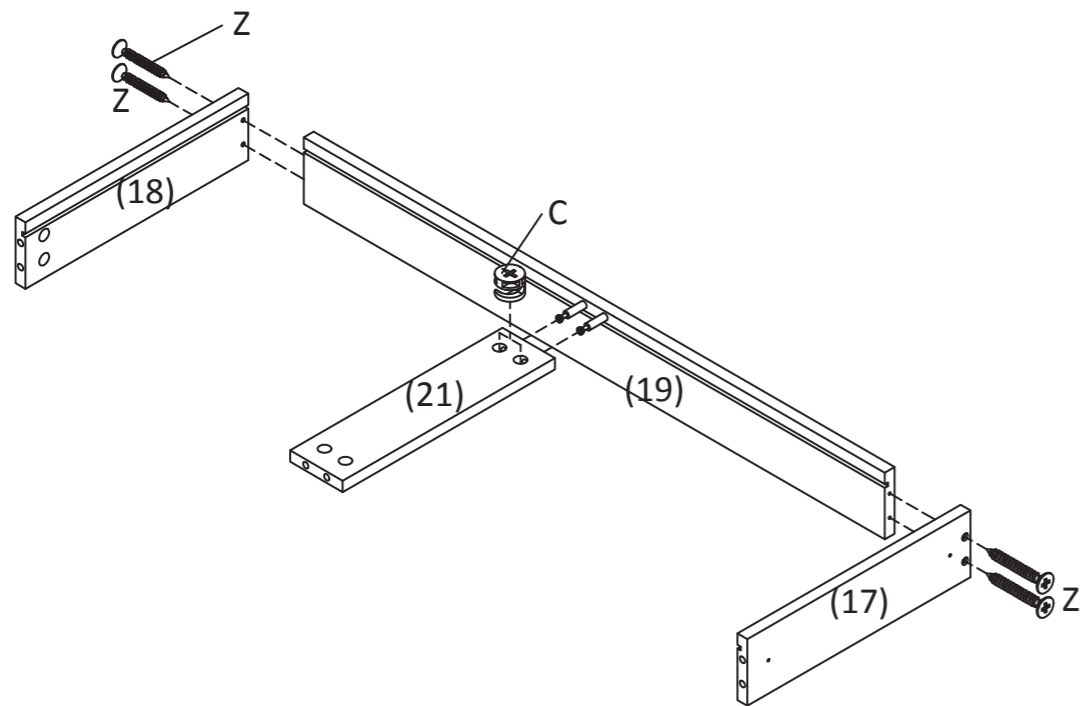

22

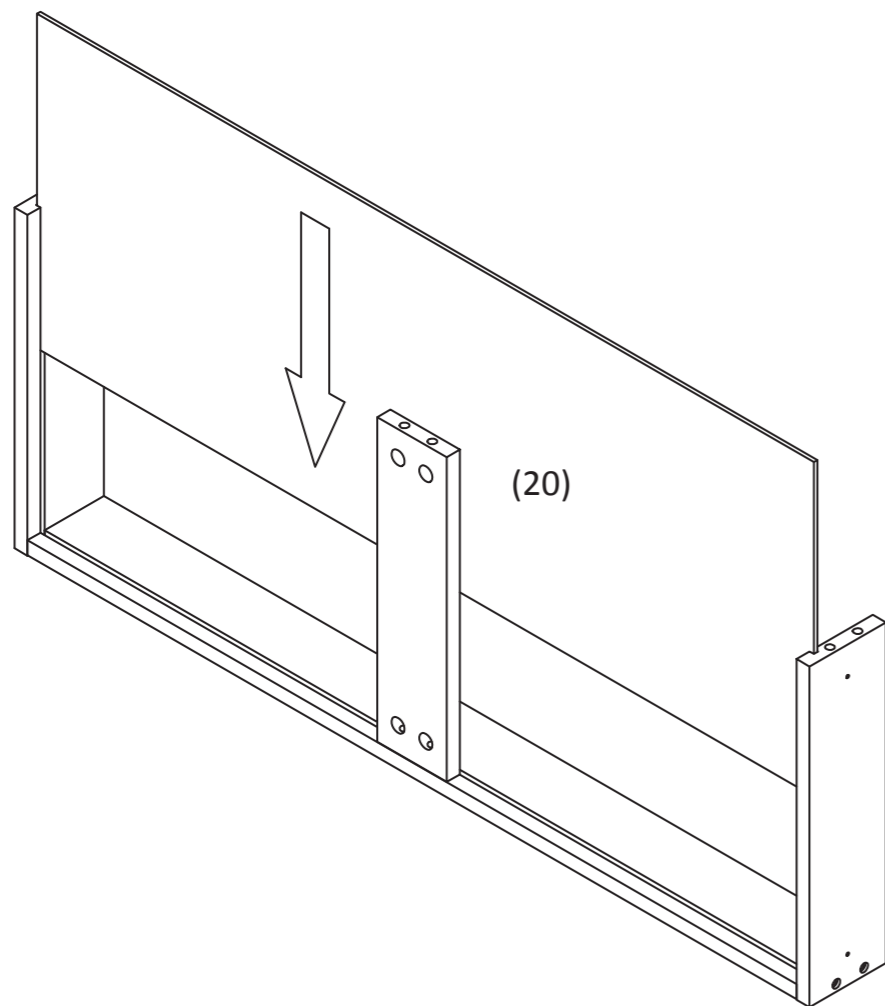

7

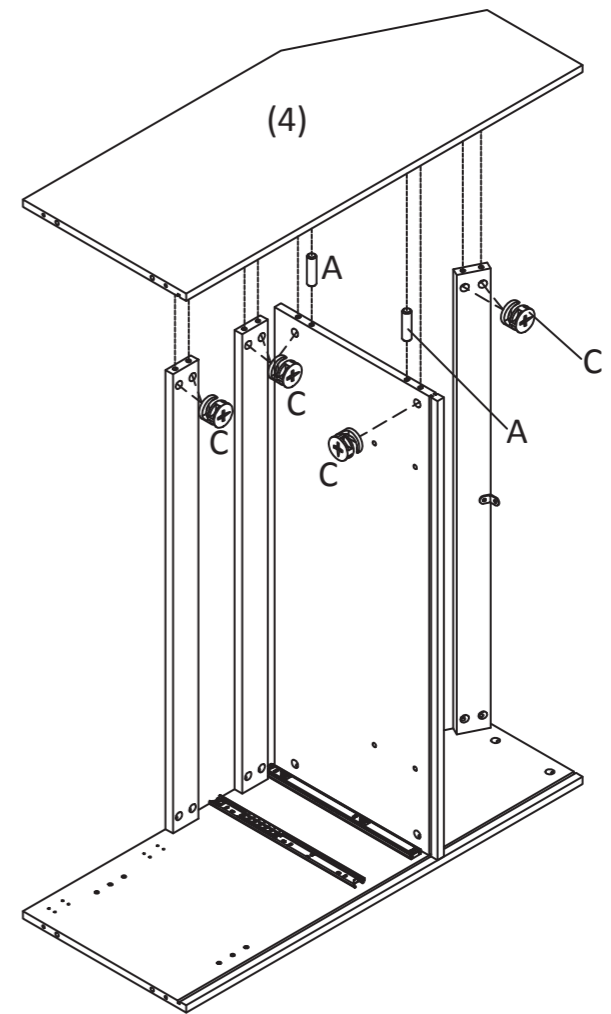

8

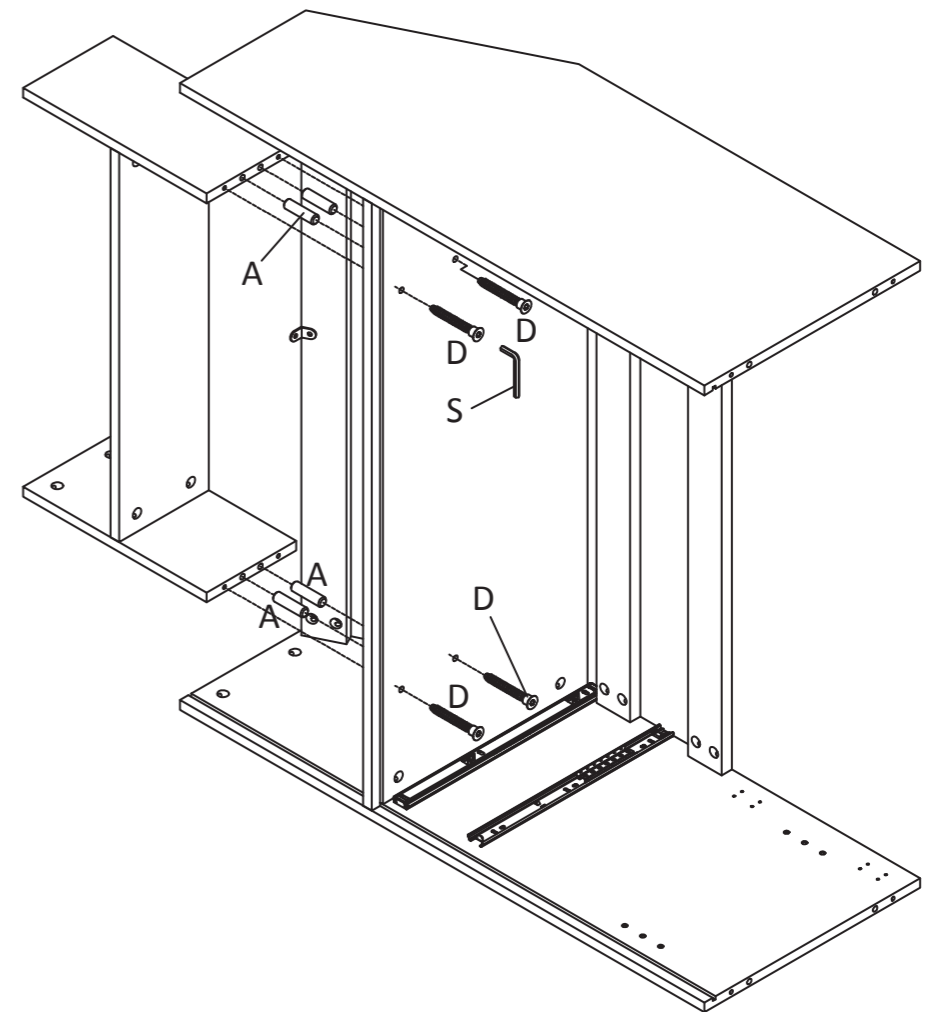

9

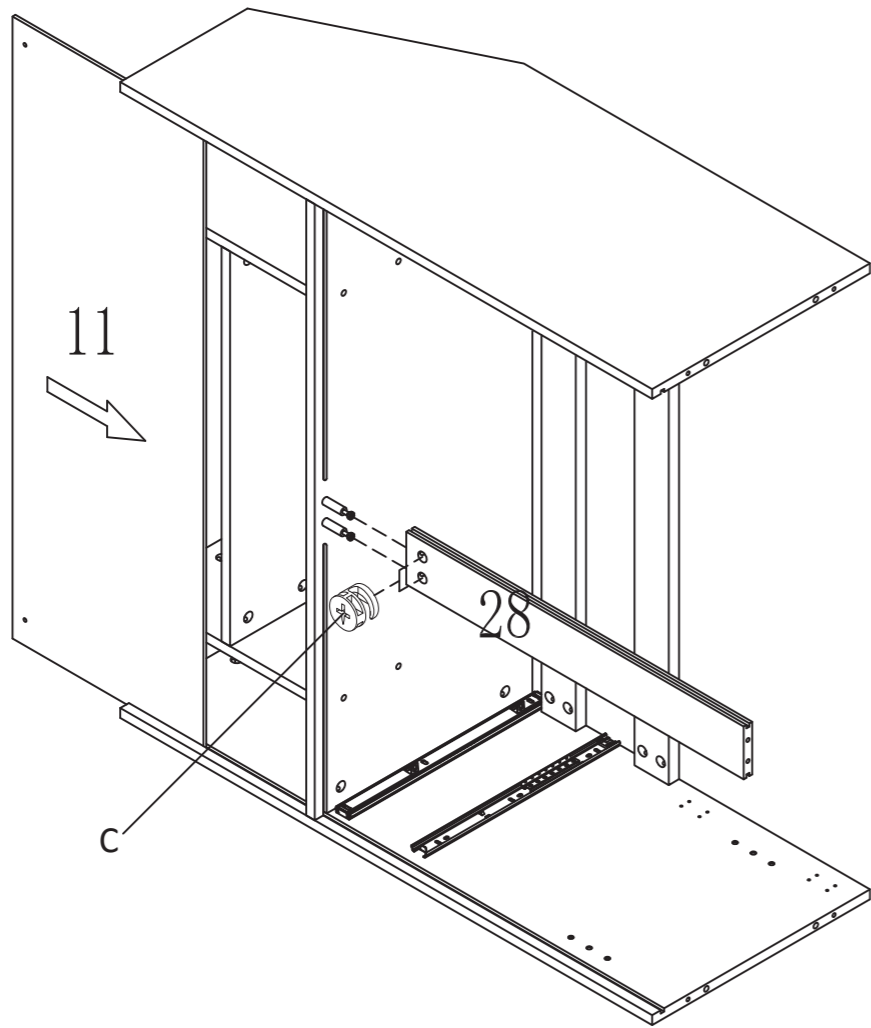

10

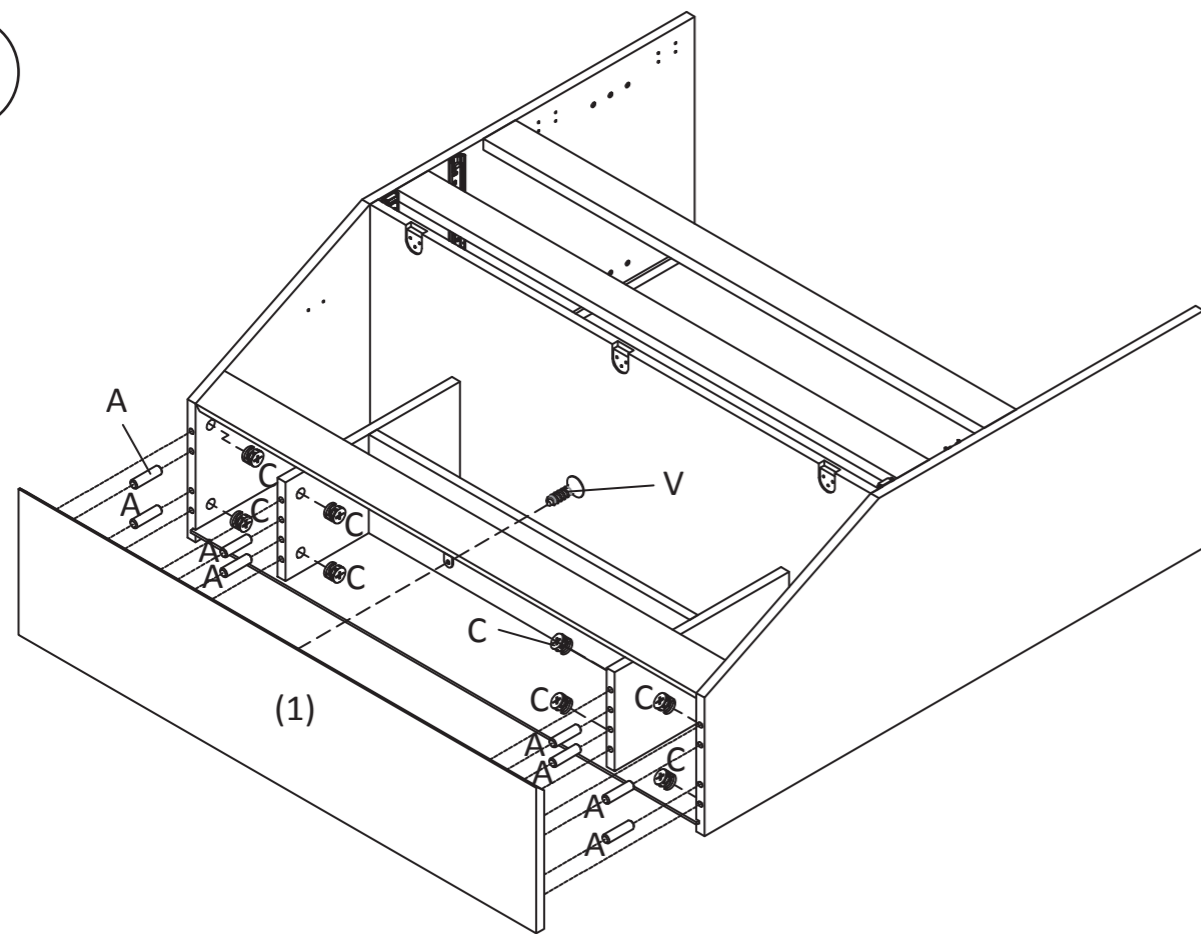

19

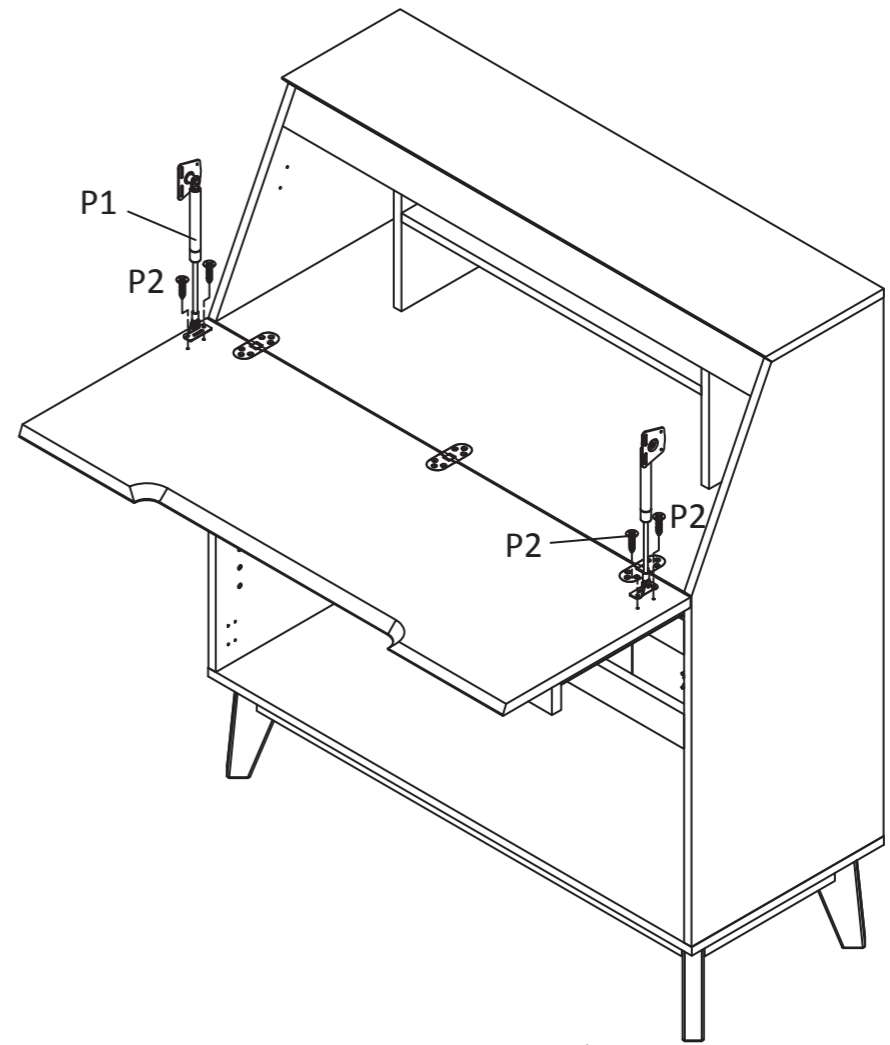

20

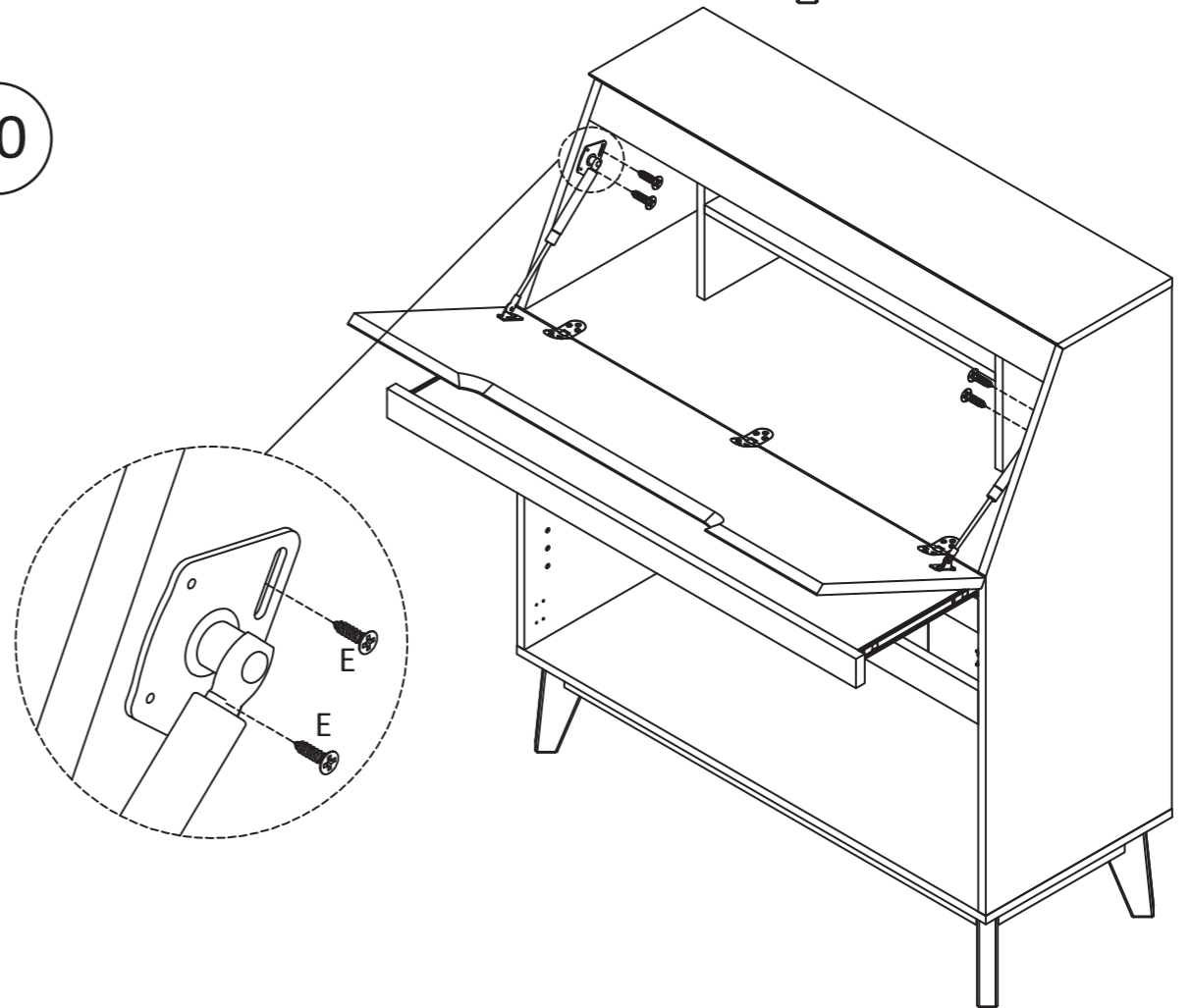

17

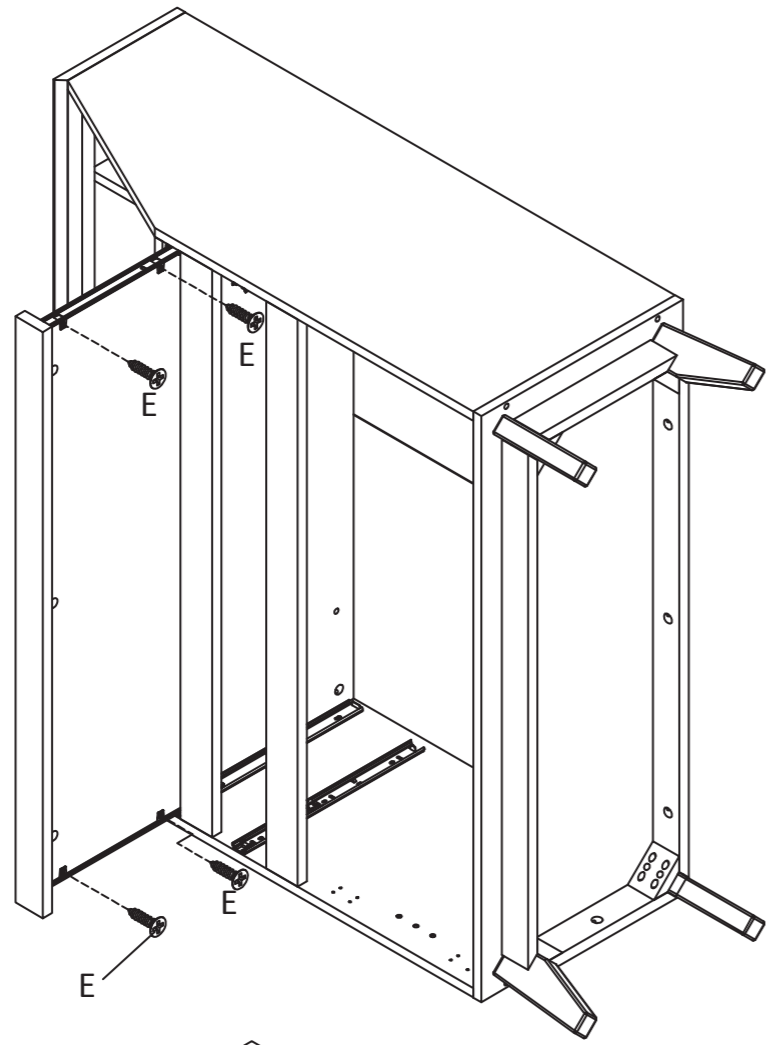

18

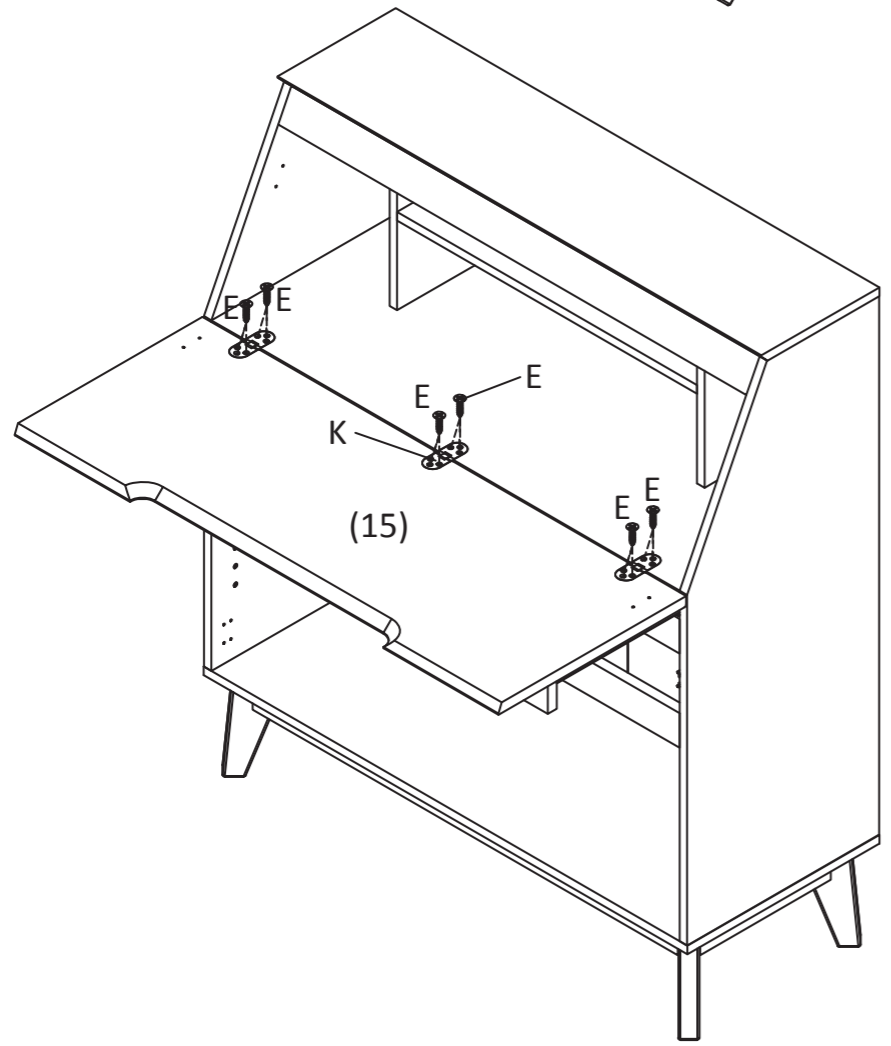

11

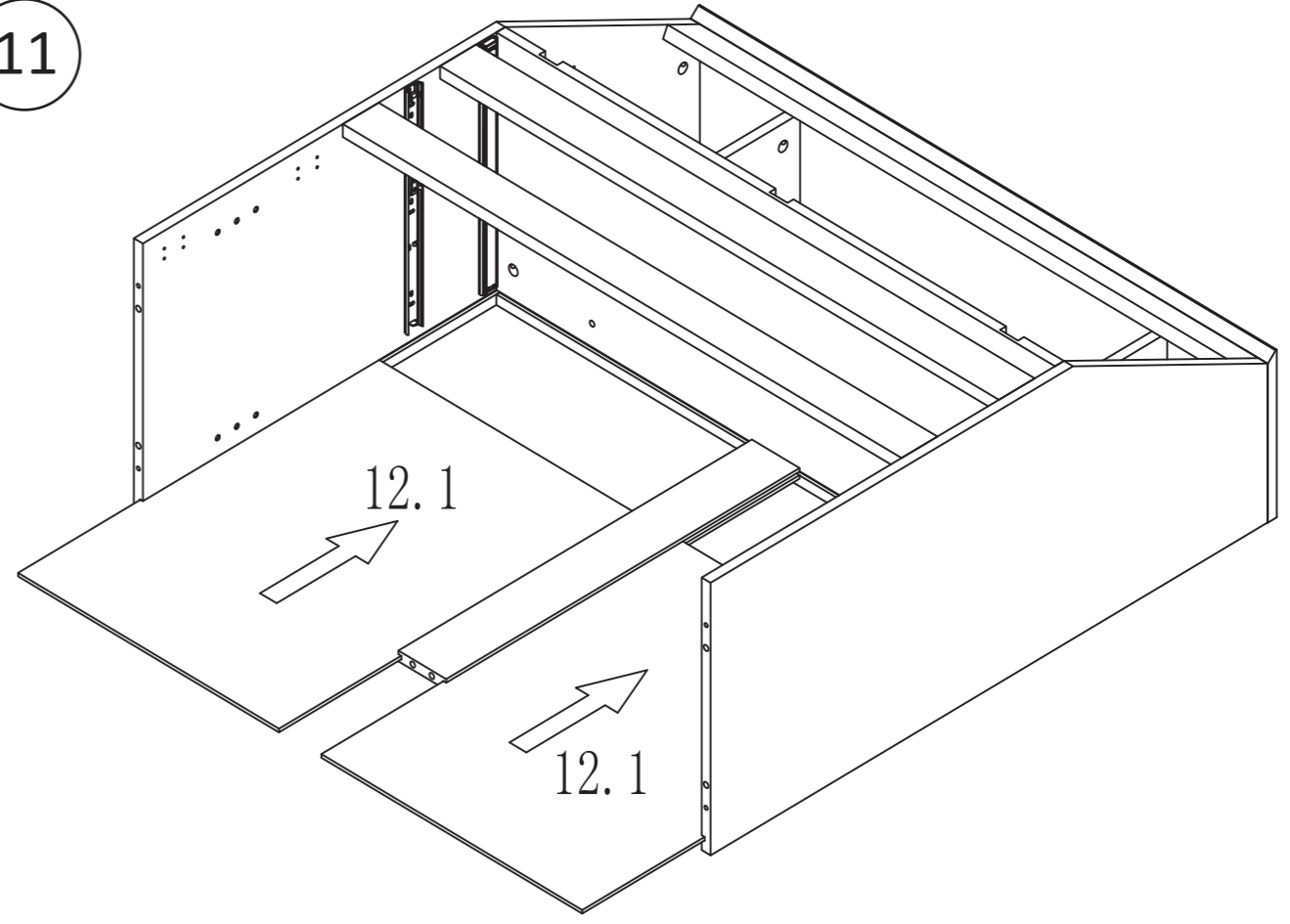

12

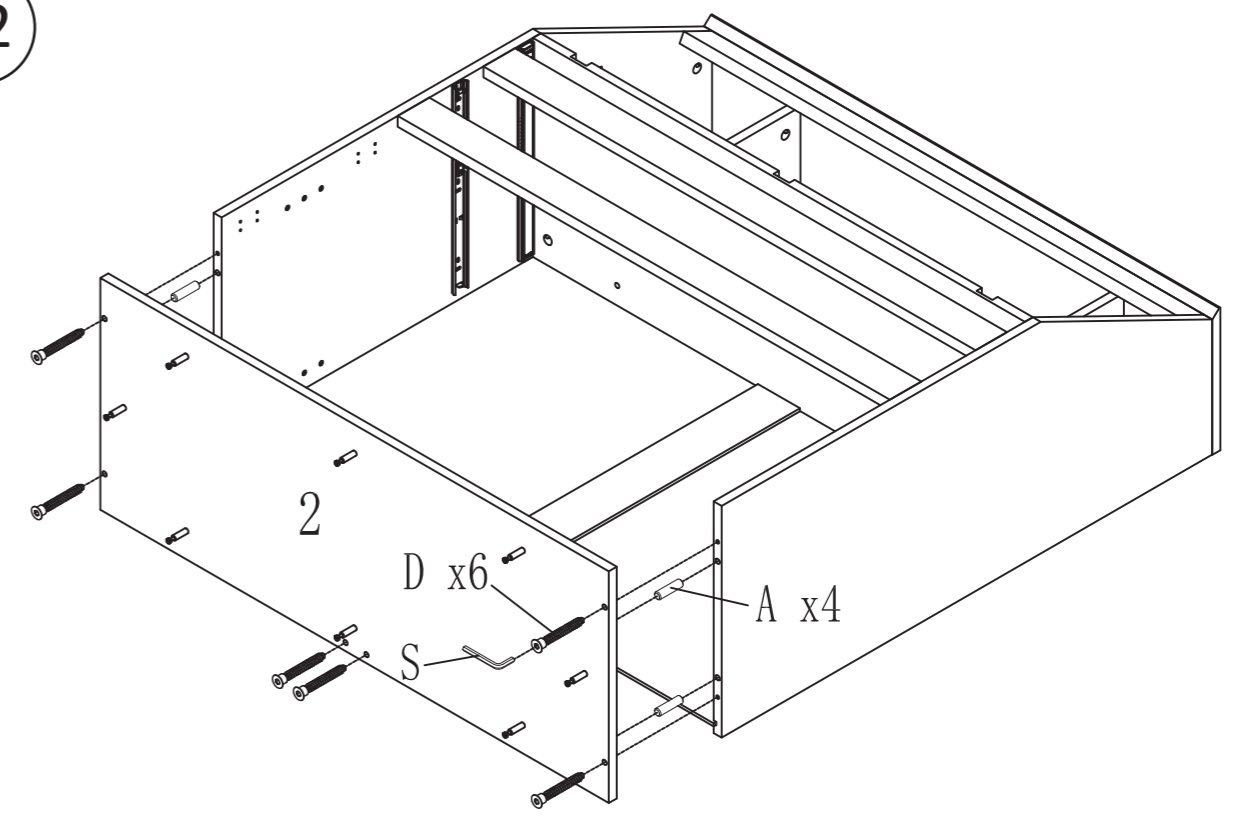

13

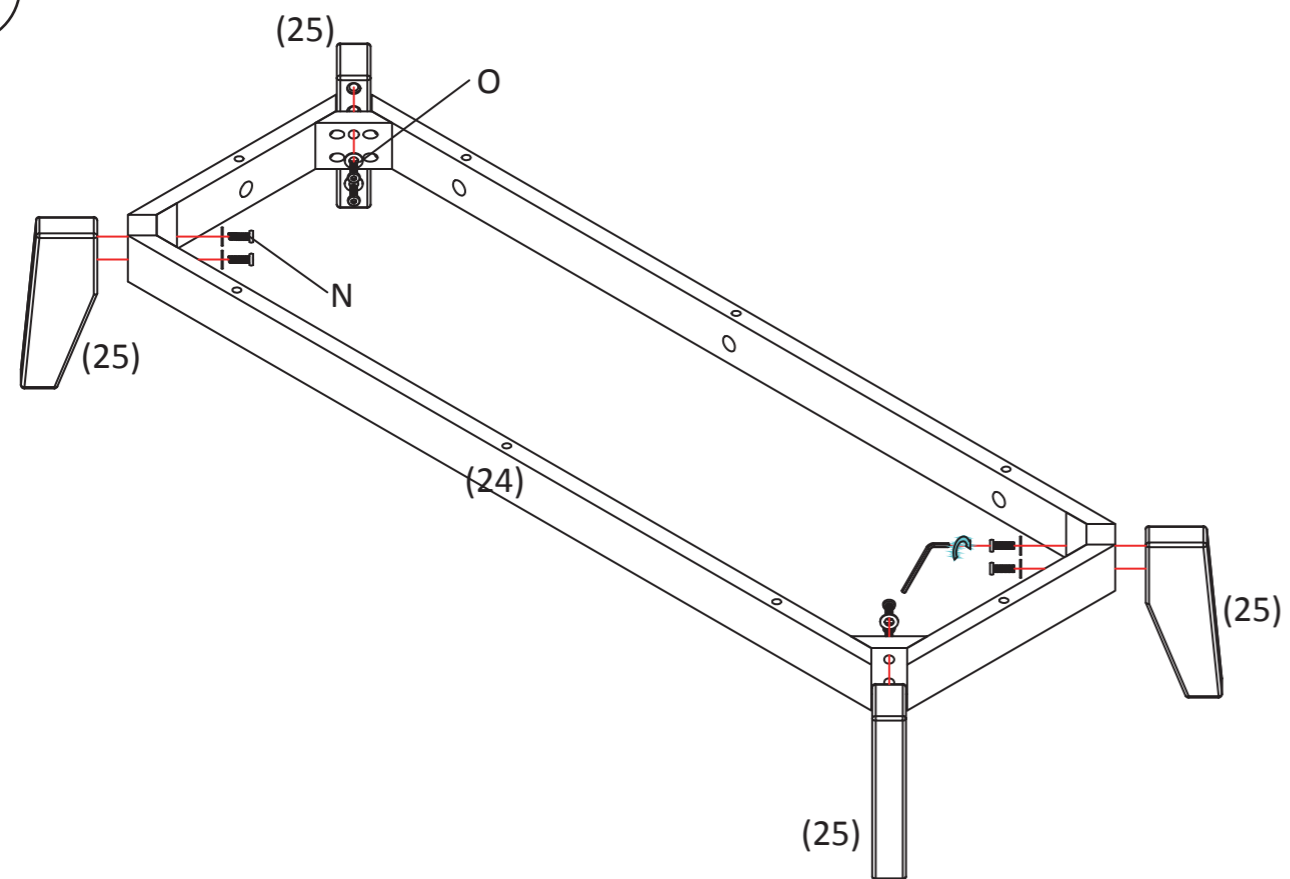

14

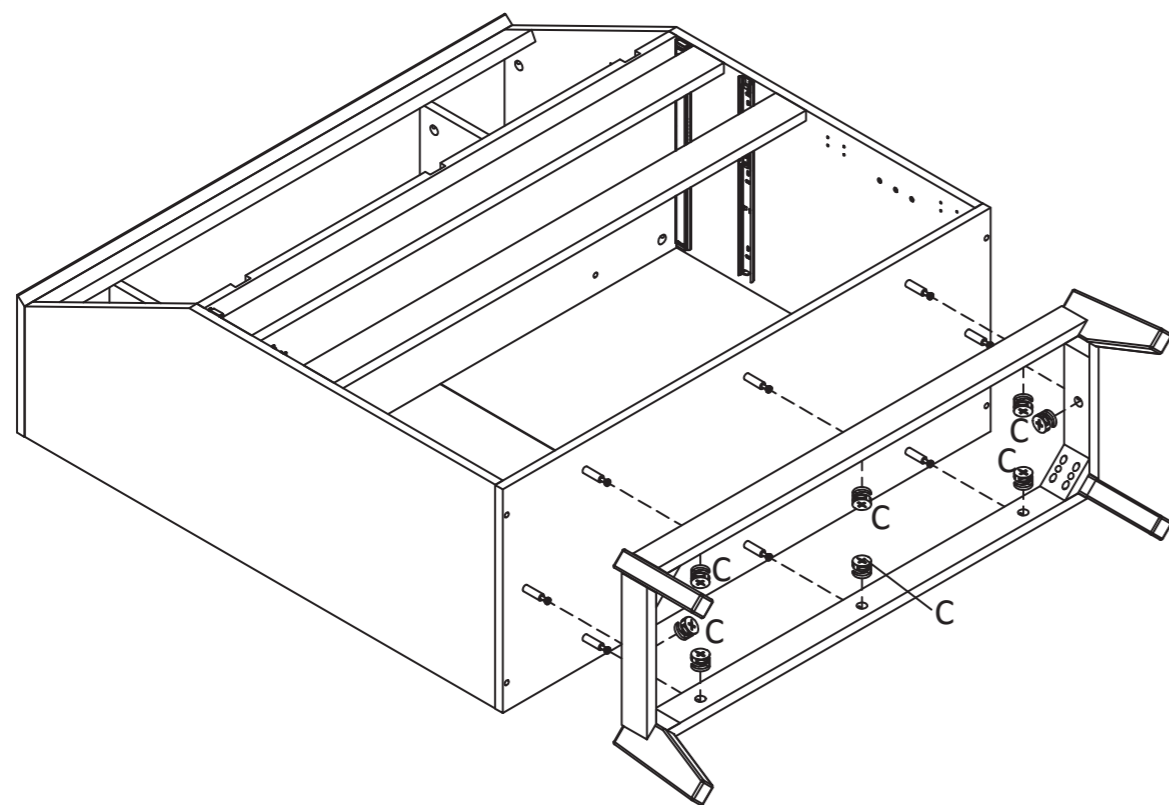

15

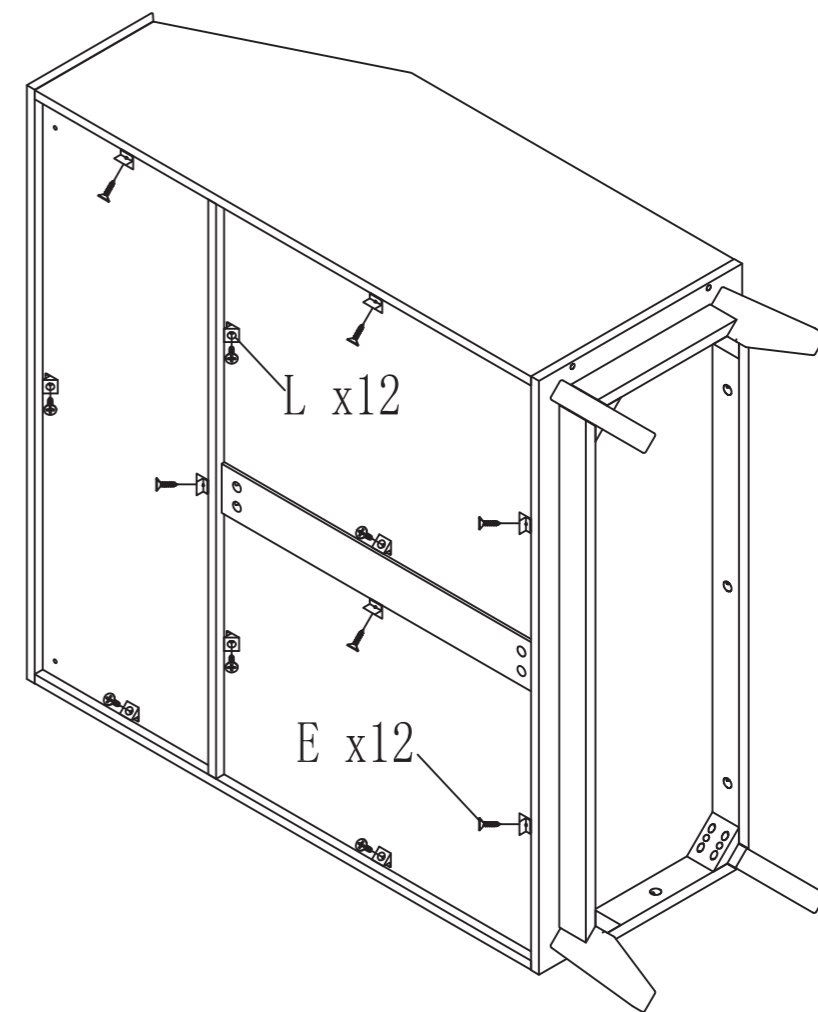

16

